

## Distributed Generation Embedded In the Iraqi Power Grid

Dr. Qais Matti Alias\* & Wael A. Jaafar\*

Received on:15/10/2009

Accepted on:7/10/2010

### Abstract

Recently, there has been great interest in the integration of distributed generation units at the distribution level. This requires new analysis tools for understanding system performance. Installing Distribution Generation (DG) in the distribution level has positive impacts on the system voltage profile as well on the substation's capacity. However the extent of such benefits depends greatly of the DG size and location.

In this work, investigation of adding diesel units regarded as distributed generators at the distribution voltage levels were done. These investigations dealt with the impact of the units addition on the Iraqi grid power flow and short circuit levels. This work is done by using PSS/E program (Power System Simulation for Engineering), A sample from substations (with fuel and space availability) of the Baghdad area were considered for the diesel units addition, in order to find recommendations for the voltage level to connect these units to it.

The extension in mind was to develop a quick rule of thumb in order to decide where to add the DG units. This of course with no regard to the unit size as it is limited by the Short Circuit Level (SCL) and economic considerations. IEEE-standard systems were considered here with the development of Matlab routines for the simulation and calculations required.

A novel quick criterion as where to add the distributed generation to minimize loss was proved. This state's "add the units at the lowest short circuit level bus, i.e., at the bus of highest Thevenin impedanc".

**Keywords:** Distributed generation, short circuit level, losses

### التوليد الموزع المدموج في شبكة القدرة العراقية

#### الخلاصة

حديثاً، كان هناك اهتمام كبير في ادخال وحدات التوليد الموزع في مستويات التوزيع. وهذا يتطلب أدوات تحليل جديدة لفهم سلوك النظام. التوليد الموزع المنصوب في مستويات التوزيع له تأثيرات ايجابية على فولتية النظام وكذلك على سعة المحطة الثانوية. وجود هذه الفوائد يعتمد بشكل كبير على حجم وموقع هذه الوحدات. في هذا العمل تم التحقيق في إضافة وحدات ديزل ينظر لها على أنها وحدات توليد موزعة في مستويات التوزيع. هذه التحقيقات تعاملت مع تأثير إضافة الوحدات على سريان الحمل ومستوى الدورة القصيرة في الشبكة العراقية. درست عينة من محطات بغداد الثانوية لإضافة وحدات الديزل فيها وذلك للخروج بتوصيات لنصب تلك الوحدات على أي مستوى من مستويات فولتية التوزيع. وأيضاً تم التوسع في التحقيقات لاستخراج قاعدة سريعة بسيطة لتقرير مكان إضافة وحدات التوليد الموزع، هذا مع عدم الأخذ بنظر الاعتبار حجم الإضافات لكونها محددة بمستوى الدورة القصيرة واعتبارات اقتصادية أخرى. IEEE استخدمت منظومات تم اثبات. لعمل المحاكاة والحسابات المطلوبة MATLAB للدراسة مع تطوير روتينات القياسية مقياس جديد وسريع لمعرفة مكان إضافة التوليد الموزع لتقليل الخسائر. وهو ينص "أضف الوحدات على العمومي الأقل دورة قصيرة".

\* Electrical & Electronic Engineering Department, University of Technology/Baghdad

## 1. Introduction

Distributed generation (DG) is related with the use of small generating units installed at strategic points of the electric power system or locations of load centers[1]. DG, for the moment loosely defined as small scale electricity generation, is a fairly new concept in electric energy markets, but the idea behind it is not new at all. In the early days of electricity generation, distributed generation was the rule, not the exception. The first power plants only supplied electric energy to consumers connected to the 'micro grid' in their vicinity. The first grids were DC based, and therefore, the supply voltage was limited, as was the distance covered between generator and consumer. Balancing demand and supply was partially done using local storage, i.e. batteries, directly coupled to the DC grid. Along with small scale generation, local storage is also returning to the scene[1].

Later, technological evolutions, such as transformers, lead to the emergence of AC grids, allowing for electric energy to be transported over longer distances, and economies of scale in electricity generation lead to an increase in the power output of the generation units. All this resulted in increased convenience and lower per unit costs. Large scale interconnected electricity systems were constructed, consisting of meshed transmission and radially operated distribution grids, supplied by large central generation plants.

The major problem of the Iraqi power grid and the electricity industry in Iraq is the shortage in generation. That of course is due mainly to

generating plants aging, plus the lack of proper routine and overhaul maintenance and sparse. In addition, the political and economic circumstances in Iraq during the past 20 to 30 years, made it difficult to install new generating capacities. Summing up, shortage in generation, rocket rise in demand and consumption, and, degradation of system components (due to aging and other reasons) all led to long hours of load shedding and operation beyond standard limits [2].

One quick solution to the situation dilemma is the installation of small size gas and /or diesel generating units (taken here as distributed generating units). Now, with the fact that load concentration in major cities and the troubled situation which impair the construction of remote power stations with the transmission facilities, the addition of these DG units has to be in the already established stations, where space and fuel are available [2].

By integrating DG into the utility's power grid, line upgrades can be postponed, and there exists the possibility of greater efficiency of power delivery. Power flows should be reduced, and thus, losses minimized. In particular, heavily loaded feeders or transmission corridors can be relieved. It may also be an opportunity to improve power quality allowing customers and utility equipment more years of usage [3, 4].

## 2. Impact of Adding DG at a Power System

### 2.1 System Frequency

The installation and connection of DG units are likely to affect the system frequency. These units will

free ride on the efforts of the transmission grid operator or the regulatory body to maintain system frequency. They will probably have to increase their efforts and having an impact on plants efficiency and emissions. Therefore, the connection of an increasing number of DG units should be carefully evaluated and planned [3, 4, 5].

### **2.2 Voltage Level**

Large scale introduction of decentralized power generating units may lead to instability of the voltage profile, that is due to the bidirectional power flows and the complicated reactive power equilibrium arising when insufficient control is introduced. The voltage throughout the grid may fluctuate. Eventually an 'islanding' situation may occur in which a local generator keeps a part of a disconnected grid energized leading to dangerous situations for the repair personnel coming in. This does not need to be a problem when the grid operator faces difficulties with low voltages, as in that case the DG unit can contribute to the voltage support. But in other situations it can result in additional problems[3, 4, 5].

### **2.3 Reactive Power**

Small and medium sized DG units often use asynchronous generators that are not capable of providing reactive power. Several options are available to solve this problem. On the other hand, DG units with a power electronic interface are sometimes capable to deliver reactive power[4,5].

### **2.4 Power Conditioning**

Some DG technologies (PV, fuel cells) produce direct current. Thus, these units must be connected to the grid via DC-AC interface, which may contribute to higher harmonics.

Special devices are also required for systems producing a variable frequency AC voltage. Such power electronic interfaces have the disadvantage that they have virtually no inertia, which can be regarded as a small energy buffer capable to match fast changes in the power balance. Similar problems arise with variable wind speed machines [3, 4, 5].

### **3. Benefits of Distributed Generation**

The benefits of distributed generation in brief are given below [5].

- i.* Transmission costs are reduced because the generators are closer to the load and smaller plants reduce construction time and investment cost.
- ii.* Certain types of DG, such as those run on renewable resources or cleaner energy systems, can dramatically reduce emissions as compared with conventional centralized large power plants.
- iii.* By generating power at or very near the point of consumption where there is congestion, DG can increase the effective transmission and distribution network capacity for other consumers.
- iv.* DG may allow consumers to sell excess power or ancillary services to power markets, thus increasing the number of suppliers selling energy and increasing competition and reducing market power.
- v.* DG can reduce reactive power consumption and improve voltage stability of the

distribution system at lower cost than voltage-regulating equipment.

- vi. DG offers grid benefits like reduced line loss and increased reliability. From a grid security standpoint, many small generators are collectively more reliable than a few big ones.

#### 4. The Iraqi rid Case Study

The solution to the power shortage which was regarded by the ministry of electricity in Iraq as the quick one is the addition of diesel units in the medium voltage level (11kV, 33kV). These units are to be operated synchronized with the grid at its power frequency. Due to many operational and economic difficulties, the installation of these diesel units was decided to be in the already established substations. The primary concern of this case study is to find and analyze the impact of adding these units on the system power flow and the SCL at the installation and nearby busses.

##### 4.1 Substations where DG is added

The addition of DG units regarding where to be added is first decided bearing in mind the space and fuel availability and load demand. Of the thirty eight substations feeding Baghdad load, four ones were chosen (two in Rusafa and two in Karkh area) to add the DG to. These were, Farabe, North Baghdad, Hurrya and Jadria substations .

Focusing on Farabe substation as a model for the others. The choice was mainly due to space availability and the high load demand in these substations[6].

##### 4.2 The unit performance

The unit terminal voltage is 11kV, these diesel units can be added directly on the 11kV bus of the substation. Moreover, they can be added to the 33kV bus via step-up transformer. The unit capacity of 23.5MVA each. Their reactive power set to be controlled by the network between,  $Q_{\min} = -4.7\text{Mvar}$  to  $Q_{\max} = 14\text{Mvar}$ . The addition of the units considered in this work is one unit at a time to a maximum of four units[7] .

##### 4.3 The used computer package

The Power System Simulation for Engineering (PSS/E-version 30.1) package was used in the simulation and calculations requirements for cases studied. The package yields the complete load flow analysis and full short circuit results [8]. The standard Newton-Raphson load-flow procedure is employed by the PSS/E. The basic load-flow equations are given in appendix-A.

##### 5. The study systematic steps

Having decided the sites to add the DG to and the amount of MVA capacity, the work proceed:-

- i- Perform a base case load flow and short circuit calculations for the Baghdad area buses. Record results regarding bus voltage, SCL, and power flows in lines connected to the bus under study.

- ii- For a chosen voltage level( 11kV,33kV) add DG in steps of one unit at a time (maximum of four units). Perform load flow and SC calculation, record the same results as in step -i.

- iii- Repeat step ii for other sites .

The aforementioned steps were performed for a certain load and generation profiles of the system.

The samples of these steps as the PSS/E program executed for the Farabe substation base case and one DG added at 11kV and 33kV buses and the tables related to are shown in figures (1, 2, 3) and tables(1, 2, 3).

### 6. Results Presentation

The load flow results of the four substations shows that, when the addition is done at the 11kV level, this make the generator either absorb or inject reactive power to the grid depending on the load behavior at this substation. But, in the case of 33kV bus the generator is always injects reactive power and this injection increase with increasing the addition. This lead to improved voltage profile. The voltage rise due to this addition in the 33kV bus was within statutory voltage limit

For the case of the SCL, the effect of this addition at the 33kV bus, raise the SCL from 17.324kA without DG to 23.574 kA with four added DG, and, in the 11kV bus raised it from 31.945kA to 51.89 kA. This makes the 33kV level as the better candidate for this addition (although a step-up transformer is needed). In the other hand the flow of active power through addition in these two buses tend to cover the local load and export the rest to the grid.

An obvious remark can be mentioned here, that, as the amount of power capacity added is very small compared to the total system power handling (*about 1 %* in our study), the impact on losses is very small and not visible due to addition of DG's.

### 7. Losses with DG addition

Distributed generators are beneficial in reducing the losses effectively compared to other methods of loss reduction [2, 3] . In order to find the

impact of DG addition on system loss, we must consider a small network. The 11- and 6-bus IEEE standard systems were considered to investigate the DG addition, in order to come out with a quick dependable rule of thumb regarding placement and size of DG addition. This is done by using a Matlab V-7 package. The algorithm tasks are to perform a standard Newton-Rapson (N-R) load flow and a three-phase short-circuit calculation.

The process starts by direct building up of the  $[Z_{bus}]$ -matrix and proceed to find the SCL using;

$$SCL^{pu} = I_f^{pu} = V_{th} / Z_{th}.$$

This is done obviously considering the prefault loading conditions, going on to add DG at each bus and perform N-R load flow to obtain losses and short circuit current The flow-chart of figure(4) exemplifies the steps followed.

The SCL is considered here as a key indicator to the amount of DG to be added without major changes in the system components. The addition of DG 's in load buses is performed through a transformer of  $X_t = 0.08pu$  leakage reactance. The DG unit itself is assumed to have an  $X_d = 0.2pu$ , of 15MW rating with  $Q_{min} = 0$ , and  $Q_{max} = 14Mvar$ .

The addition of DG's was performed for the base case load profile and for an increase in total system load of about 14.5%. One DG unit and two DG's additions were considered in order to quantify and analyze the impact of the addition on the resulting system losses and SCL.

### 8. Test Systems Studied and Results

Two standard test systems were considered for the implementation of the procedure presented in paragraph-

7. These systems were, the IEEE-11 bus and the IEEE-6 bus. For brevity, emphasis placed on the former system regarding, presentation results and analysis. Figure (5), shows the single line diagram of the IEEE-11bus system, bus, line and generator data of this system are shown in appendix-B.

Table (4) lists the losses encountered in the system with the basic load profile. The total system losses without DG addition was  $11.347(\text{MW})+j57.181(\text{Mvar})$ . It is clear in this table that, the minimum system losses was obtained when the DG additions are in bus -5. The addition of DG resulted in reduced system active losses. The reduction ranges from 3.24%(one DG added at bus 3) to 7.84% (two DG's added at bus 5). As far as the system reactive losses are concerned, the reduction ranges from - 0.83% (one DG added at bus 3) to 11.55% (two DG's added at bus 5). The negative sign means an increase in the system reactive losses.

Table (5) shows the system losses obtained for the system with the load increased by 14.5%. The system losses without DG addition was  $19.218(\text{MW})+j106.672(\text{Mvar})$ . The same pattern as in the previous case was observed, *i.e.*, minimum losses were obtained for DG addition in bus -5. The boundaries for the total losses reduction were, 2.63% to 19.61% for the active power losses and 2.4 % to 26.07 % for the reactive power losses.

Tables (6) and (7) list the system SCL for the five load busses. Bus 5 has the lowest SCL for both loading cases.

It is a well known fact that system losses are dependent on load profile and system topology regarding

connections, load and generation scattering over system buses.

Similarly, system SCL follows the same pattern with small dependence on system load profile. These facts in mind along with the results discussed previously for the system under study, a very important note can be drawn here. That is, for minimum system losses, add DG at the minimum SCL bus. In other words, a simple rule of thumb, here stated as "add DG at the bus of the highest Thevenin's impedance".

Finally, the same study procedure was applied on the IEEE -6 bus system. The same observations, remarks, and conclusions were drawn here as those for the IEEE-11bus system.

## 9. Conclusions

Distributed generation in context is the accommodation of small sized generating units in the distribution network. Globally DG are mainly of renewable energy sources.

Due to the shortage in electrical power generation and diesel fuel availability plus the time factor consideration, the ministry of electricity in Iraq proposed the addition of small diesel units at the distribution voltage levels (regarded here as DG units). The substations to connect DG to are already fixed according to space and load demand requirements.

In this work, the impact of the DG addition to the Iraqi power system is investigated. The two main issues addressed were the power system losses and the SCL at the addition and nearby buses.

Extensive series of simulations were performed adding DG's (one to four units) at a chosen distribution



substation voltage levels *i.e.*, 11kV, 33kV.

The impact of the addition on the system power losses was minimal in all cases studied as the amount of power added was very small compared to the total system handling capacity .

A very noticeable increase in the SCL was observed when the DG addition was at the 11kV buses. Hence addition at this voltage level is not recommended despite the ease of addition as the DG unit terminal voltage is also 11kV.

As for the addition at the 33kV level is concerned , it is clear from the results of Iraqi substations that the impact of addition on the SCL is low compared to that at the 11kV level. Therefore, acceptable SCL profile is obtained making better the addition at the 33kV level, despite the fact that extra transformer and auxiliaries are required.

A novel finding is deduced regarding the proper site to add DG to. That finding is, “add the DG to the bus of highest Thevenin impedance”

That was concluded after extensive series of studies simulating a standard IEEE systems using Matlab routines.

**10. References**

[1]. L. L. Lai and T.F. Chan "Distributed Generation" 2007 John Wiley & Sons, Ltd.  
 [2] Wael A. Jaafar ", *Distributed generation embedded in the Iraqi Power Grid*" Thesis submitted to the University of Technology 2009.  
 [3]. Tom Hammons and Zbigniew Styczynski " *impact of dispersed and renewable Generation on system*

*structure"* IEEE 2006 General Meeting, Montreal, June 2006.

[4]. I. Kromer, Z. Bessenyei “, **Impacts Of Dispersed Generation Technology On Reliability Of Electricity Supply**” Institute of Electric Power Research Gellertthey u. 17. Budapest, Hungary2006.  
 [5] section 1817 of the Energy Policy Act of 2005 "**The Potential Benefits of Distribution Generation**" .  
 [6] Iraqi Ministry of Electricity Department Of Planning and Training, report 2009.  
 [7] *Iraqi Ministry of Electricity, "Annual book 1990 and Annual reports, 2004"*.  
 [8] *PSS/E user manual .*  
 [9] Saadat, Hadi ."*Power System Analysis*", McGraw-Hill, Inc. 2<sup>nd</sup> edition ,2004.

**APPENDIX-A**

**Newton-Raphson Power Flow**

The Newton-Raphson load flow is summarized below, assuming the basic variables are given in polar form, hence;

$$V_i = |V_i| \angle \delta_i$$

$$Y_{ij} = |Y_{ij}| \angle \theta_{ij}$$

$$P_i - jQ_i = V_i^* I_i = (\sum_{j=1}^n |Y_{ij}| |V_j| \angle \theta_{ij} + \delta_j - \delta_i)$$

Hence P and Q can be expressed as,

$$P_i = \sum_{j=1}^n |V_i| |V_j| |Y_{ij}| \cos(\theta_{ij} - \delta_i + \delta_j)$$

$$Q_i = - \sum_{j=1}^n |V_i| |V_j| |Y_{ij}| \sin(\theta_{ij} - \delta_i + \delta_j)$$

It can be seen that change in power is related to the change in voltage magnitude and phase angle as:-

$$\begin{bmatrix} \Delta P_i^k \\ \Delta Q_i^k \end{bmatrix} = \begin{bmatrix} J_1^k & J_2^k \\ J_3^k & J_4^k \end{bmatrix} \begin{bmatrix} \Delta \delta_i^k \\ \Delta |V_i^k| \end{bmatrix}$$

**Table (1) Farabe Base case load flow results**

BUS Code	BUS No.	Total Flow in		Total Flow Out		S C L	V	V kV
		MW	Mvar	MW	Mvar	kA	PU	Actual
FRBI	16327	112.9	61.2	112.8	61.2	27.433	1.023	135.03
MTHN	16331	/	13	8.9	/	27.531	1.023	135
RUSF1	16366	19.4	15.7	/	/	26.125	1.023	135
RUSF2	16366	19.4	15.7	/	/	26.125	1.023	135
RUSF3	16366	19.4	15.7	/	/	26.125	1.023	135
NFRB1	16372	/	/	52	30.6	25.125	1.025	135.3
NFRB2	16372	/	/	52	30.6	25.125	1.025	135.3
FRB6	16527	36.8	28	/	/	17.324	0.971	32.043
FRB1	16127	18	13.6	/	/	31.945	1.007	11.1

ded at the 11kV bus.

**Table (2) load flow results, one DG added at the 11kV bus.**

BUS Code	BUS No.	Flowin MW Mvar	Flow Out		S C L	V	V kV
			MW	Mvar	k A.	PU	Actua l
FRBI	16327	101.6 61.6	101.5	61.5	27.778	1.028	135.02
MTHN	16331	3.7 9.8	/	/	27.876	1.023	135
RUSF1	16366	19.4 15.7	/	/	26.439	1.023	135
RUSF2	16366	19.4 15.7	/	/	26.439	1.023	135



RUS	163	19.4		/	/	26.439	1.023	135
F3	66	15.7						
NFR	163	/	/	50.8	30.7	25.426	1.025	135.3
B1	72							
NFR	163	/	/	50.8	30.7	25.426	1.025	135.3
B2	72							
FRB6	165	36.6		/	/	18.975	0.967	31.9
	27	28						
FRB1	161	3		/	/	36.802	1	11
	27	18.4						

Table(3) Farabe-load flow results, one DG added at the 33kV bus.

BUS Code	BUS No.	Total Flow In		Total Flow Out		S C L k A	V PU	V kV Actual
		MW	Mvar	MW	Mvar			
FRBI	1632 7	101.6	59.8	101.6	59.6	27.767	1.0242	135.195
MTH N	1633 1	3.8	19.5	/	/	27.865	1.024	135.2
RUSF 1	1636 6		19.4 15.7	/	/	26.43	1.024	135.1
RUSF 2	1636 6		19.4 15.7	/	/	26.43	1.024	135.1
RUSF 3	1636 6		19.4 15.7	/	/	26.43	1.024	135.1
NFRB 1	1637 2	/	/	50.7	29.8	25.42	1.026	135.5
NFRB 2	1637 2	/	/	50.7	29.8	25.42	1.026	135.5
FRB6	1652 7	21.6	22	/	/	18.924	0.979	32.3
FRB1	1612 7	18	13.6	/	/	33.913	1.015	11.2

**Table (4) Total system Losses with basic load profile, {System losses=11.347(MW)+j57.181(Mvar), (no DG added)}.**

DG addition at bus	losses			
	One DG added		Two DG added	
	p (MW)	Q(Mvar)	p (MW)	Q(Mvar)
3	10.9	57.6	10.6	55.8
5	10.5	54.7	9.9	50.5
6	10.8	57.0	10.4	54.9
7	10.7	56.3	10.3	53.8
8	10.6	55.8	10.0	52.5
9	10.6	55.8	10.0	52.6

**Table (5) Total system losses with load increased by 14.5% {system losses=19.218(MW)+j106.672(Mvar) ,(no DG added)}**

DG addition at bus	losses			
	One DG added		Two DG added	
	p (MW)	Q(Mvar)	p (MW)	Q(Mvar)
3	18.70	104.04	18.24	101.5
5	17.03	99.23	15.41	78.66
6	18.56	103.32	17.93	100.1
7	18.30	101.5	15.86	82.52
8	17.22	101.17	15.70	81.71
9	17.15	101.1	17.18	96.1

Table (6) Short circuit level (Basic load profile).

DG addition at bus	SCL (PU)		
	No DG	One DG	Two DG
3	4.33	7.85	9.81
5	1.52	4.94	6.86
6	4.32	7.81	9.77
7	4.16	7.76	9.76
8	3.35	6.80	8.73
9	2.22	5.62	7.53

Table (7) short circuit level  
(load increased by 14.5%).

DG addition at bus	SCL (PU)		
	No DG	One DG	Two DG
3	4.26	7.71	9.65
5	1.45	4.73	6.87
6	4.24	7.63	9.74
7	3.99	7.48	9.77
8	3.24	6.54	8.71
9	2.14	5.40	7.51

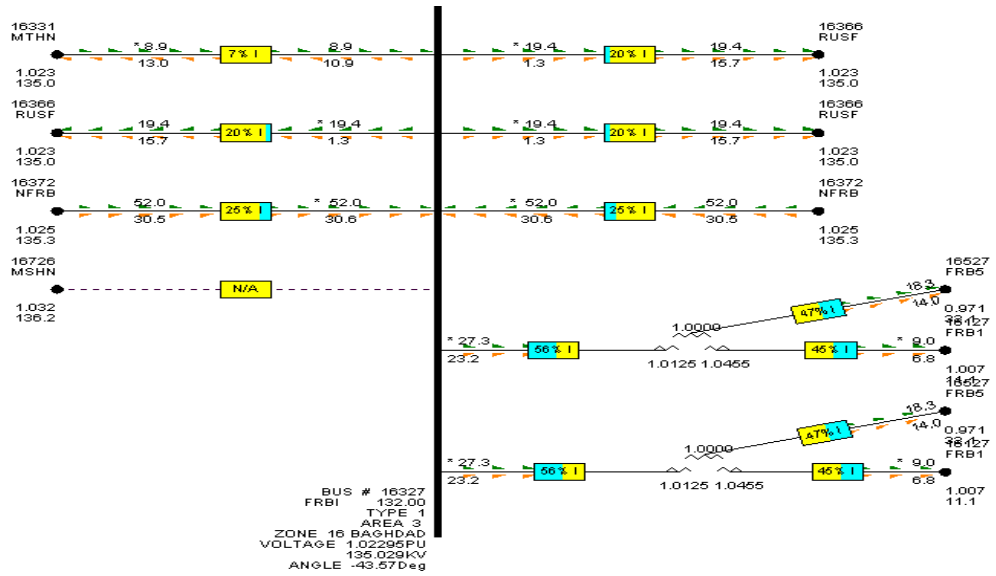

Figure (1) Farabe-132kV bus and connections, base case load flow results.

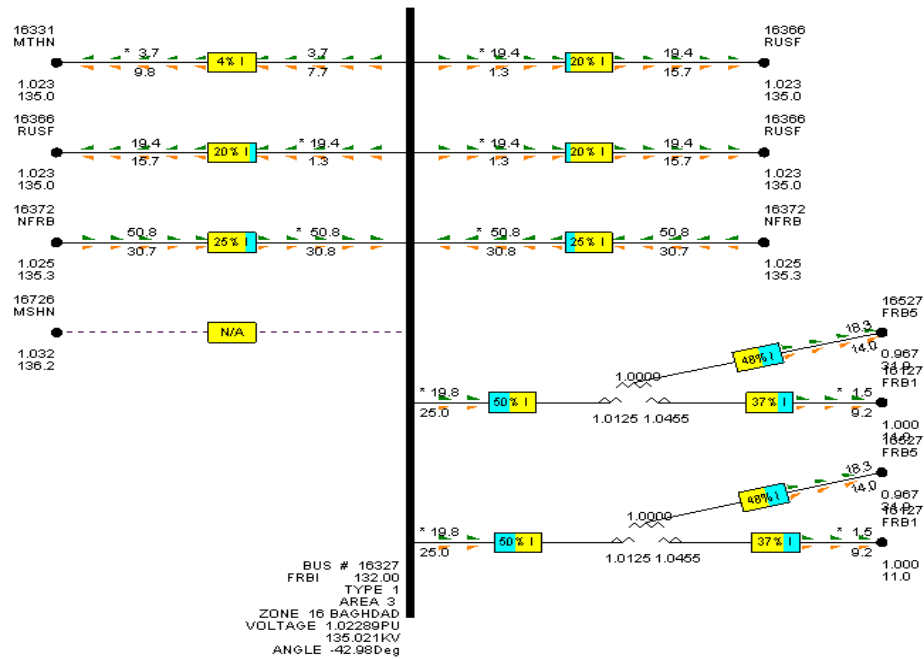

Figure (2) Farabe-132kV bus and connections load flow results, one DG ad

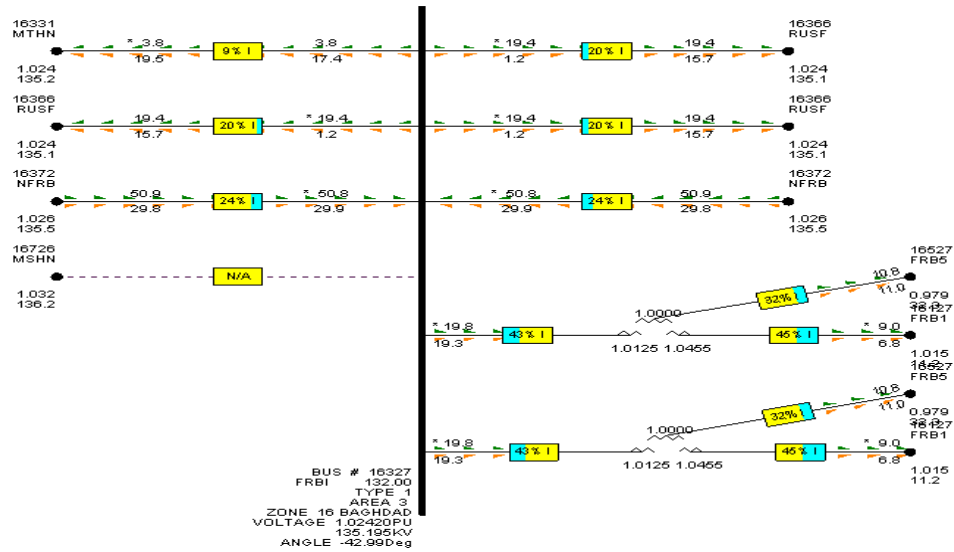

Figure (3) Farabe-132kV bus and connections load flow results, one DG added at the 33kV level.

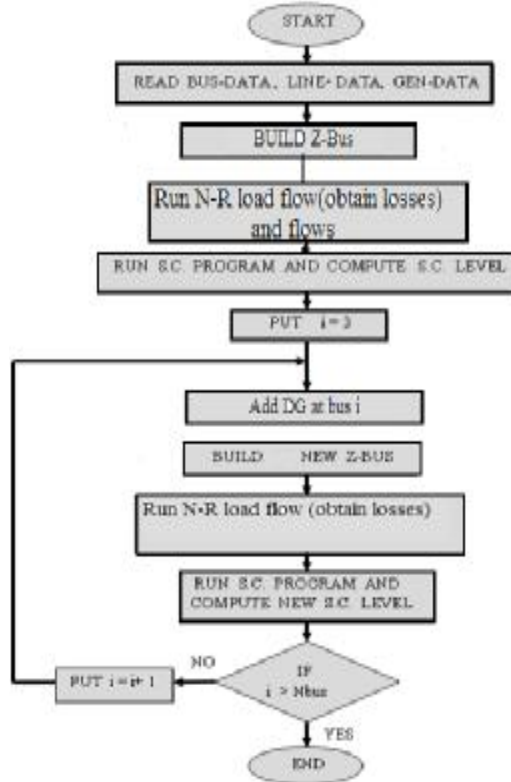

Figure (4) Flow chart of general algorithm

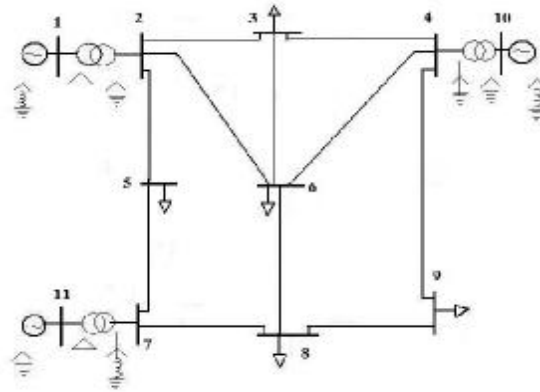

Figure (5). Single line diagram, the IEEE-11 bus system

**APPENDIX-B**

The IEEE 11-bus system data.

Table ( B.1 ). Bus data of the 11 bus IEEE-11bus system.

Bus No.	BusT ype	V  Mag.	V Ang.	Load		Generation		Generator MVAR	
				MW	MVAR	MW	MVAR	Min.	Max
1	1	1.04	0.0	0.0	0.0	0.0	0.0	0.0	0.0
2	0	1.0	0.0	0.0	0.0	0.0	0.0	0.0	0.0
3	0	1.0	0.0	160.0	125.0	0.0	0.0	0.0	0.0
4	0	1.0	0.0	0.0	0.0	0.0	0.0	0.0	0.0
5	0	1.0	0.0	120.0	90.0	0.0	0.0	0.0	0.0
6	0	1.0	0.0	140.0	110.0	0.0	0.0	0.0	0.0
7	0	1.0	0.0	0.0	0.0	0.0	0.0	0.0	0.0
8	0	1.0	0.0	115.0	95.0	0.0	0.0	0.0	0.0
9	0	1.0	0.0	100.0	80.0	0.0	0.0	0.0	0.0
10	2	1.035	0.0	0.0	0.0	200.0	0.0	0.0	180
11	2	1.03	0.0	0.0	0.0	160.0	0.0	0.0	120

**Table (B.2). Generator data**

Bus No.	R1 P.U.	X1 P.U.
1	0	0.2
10	0	0.15
11	0	0.25

**Table (B.3 ). Line data of the IEEE-11 bus system.**

From Bus	To Bus	R1 P.U.	X1 P.U.	B P.U.
1	2	0.00	0.06	0.0000
2	3	0.08	0.30	0.0004
2	5	0.04	0.15	0.0002
2	6	0.12	0.45	0.0005
3	4	0.10	0.40	0.0005
3	6	0.04	0.40	0.0005
4	6	0.15	0.60	0.0008
4	9	0.18	0.70	0.0009
4	10	0.00	0.08	0.0000
5	7	0.05	0.43	0.0003
6	8	0.06	0.48	0.0000
7	8	0.06	0.35	0.0004
7	11	0.00	0.10	0.0000
8	9	0.052	0.48	0.0000