

## Controlling a Nonlinear Servo Hydraulic System Using PID Controller with a Genetic Algorithm Tool

Shaymaa Mahmood Mahdi\*

Received on: 25/5/2011

Accepted on: 13/12/2011

### Abstract

The purpose of this paper is to present the modeling and simulation of a servo hydraulic system. Hydraulic systems are broadly used in the industry due to their ability to adapt to a wide range of purposes and their proven robustness. First we develop a mathematical model to obtain the system responses. These responses represent the response of the servo hydraulic system with a sinusoidal input. Secondly, we design a PID controller in order to improve the position transient response and reach minimum steady state error in the output displacement. Then, we use Genetic Algorithm technique to find the best ( $K_P$ ,  $K_I$  and  $K_D$ ) gains for PID controller to enhance the output of the servo hydraulic system.

The results have showed a higher improvement of the servo hydraulic system response with minimizing the steady state error after using the PID controller gains obtained from the Genetic Algorithm technique.

**Keywords:** servo hydraulic system, Genetic Algorithm technique.

السيطرة على النظام الغير الخطي الهيدروليكي باستخدام المسيطر التناسبي- التكامل- التفاضلي مع أداة التحكم الخوارزمية الجينية

### الخلاصة

ان الغرض من هذا البحث هو تقديم النمذجة والمحاكاة لأجهزة النظام الهيدروليكي وذلك لاستخدام الأنظمة الهيدروليكية في نطاق واسع في الصناعة نظرا لقدرتها على التكيف مع مجموعة واسعة من الاستخدامات ومثانتها المؤكدة. يحاكي النظام الحقيقي بتطوير نموذج رياضي للحصول على استجابات النظام. هذه الردود تمثل استجابة النظام الهيدروليكي مع أجهزة الادخال الجينية. ثم نقوم بتصميم مسيطر تناسبي- تكامل- تفاضلي من أجل تحسين استجابات النظام ثم محاولة تحسين استجابات النظام للوصول الى دقة اكبر وذلك بأستخدام خوارزمية التقنية الوراثة للعثور على أفضل متغيرات المسيطر التناسبي- التكامل- التفاضلي. النتائج تظهر تحسن في دقة المواقع اللحظية واستجابة النظام الهيدروليكي مع الوصول إلى اقل نسبة خطأ بعد استخدام متغيرات المسيطر التناسبي- التكامل- التفاضلي الذي تم الحصول عليها من تقنية الخوارزمية الوراثة.

\*Control and Systems Engineering Department, University of Technology.

## 1. Introduction:

Hydraulic actuators are important equipment in modern applications and widely used in industry because of their high power capability, fast and smooth response characteristics and good positioning capability [1]. They begin to gain wide acceptance in a variety of industries for their small size to power ratios, smoother performance at low speeds, wide speed range and its ability to apply very large force and torque. These systems are still heavily used in high-performance applications such as manufacturing systems, material test machines, flight simulation, ships and robotics.

In hydraulic applications, the highest performance of the electrohydraulic actuators can be obtained by setting their position, force or pressure needed in this case. However, the problems of the hydraulic system actuators are their nonlinearities and low damping. Hence for some applications, these systems are difficult for accurate control. To improve the performance of the electro-hydraulic actuator, a suitable controller is required [1].

Different types of automatic controllers are used in the literature such as in V. Pastrakuljic [2] who proposed nonlinear mathematical model of the Electro Hydraulic Actuator (EHA) that gives good correspondence with experimental data and can be used for system studying or controller design.

While A. AIROUCHE, et al, [3] introduced a mathematical model of the servo-hydraulic system by using a PID controller with the assistance of the Station Manager window's in MTS Flex Test GT Software which selects an access level of tuning the controller parameter.

M. Mihajlov et al [4] investigated the performance improvement of variable structure control systems for position

tracking of an electro-hydraulic servo system. They used the combination of sliding mode controller with Fuzzy PI controllers to track the error in the presence of additional disturbances.

H. Yousefi [5], studied two different servo-hydraulic systems identified and then controlled by a fuzzy gain-scheduling Controller. Also they, H. Yousefi, et al [6], presented the Differential Evolution (DE) algorithm which is one of the most promising novel evolutionary algorithms for solving global optimization problems. DE can handle non-linear constraint functions with boundary limits of variables to find the best values for the unknown parameters of a servo-hydraulic system with a flexible load.

While I. Algelli, et al [7] analyzed all relevant properties of the electro hydraulic systems and based on that he made a proper choice of the control strategy that may be used for the control of the servomechanism system.

T.M. Menshawy et al, [8] used a proportional and servo valves to control the velocity, or force of an actuator. A simulation model of the hydraulic cylinder with vertical load has been carried out. Also D. Maneetham and N. Afzulpurkar [9] worked on the modeling of a linear Hydraulic Servo System and described the design and implementation of a control system for the operation of a hydraulic mini press machine.

Gregov, G. et al [10] selected some problems related to modeling and simulation of hydraulic servo-systems (valve & cylinder), using MATLAB-Simulink package. The simulation results are compared with laboratory measurements. C. H. Corteline, et al. [11] presented effects of air in hydraulic control system. The study is based on models of: the mixture of air with hydraulic fluid, the servo hydraulic control system and experimental

identification. On the other hand Y. Jiangang, et al [12] proposed a solution to the non-symmetrical structure of the hydraulic cylinders in the angle position, by improving a digital PID control algorithm with variable sampling periods.

The paper is organized as follows. Section 2 presents the dynamic equations of the system under study. More details of the system Simulink model is described in Section 3. An improvement and comparison between using a PID controller after tuning in two different methods are discussed in Section 4. An introduction to the Genetic Algorithm technique is given in Section 5 and finally conclusions are drawn in Section 6.

## 2. Servo Hydraulic System Mathematical Representation

In order to study the response behavior of the servo hydraulic system a mathematical equation for each part is represented starting from the dynamic of the cylinder and the friction behavior to the change of the pressure that depends on the mass flow rate changes from the servo valve changing input voltage. The following is a schematic diagram of the system given in figure (1).[5,6].

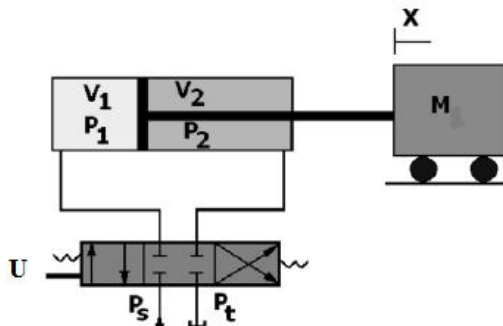

Figure (1). Schematic diagram of servo hydraulic system.

### 2.1 Hydraulic actuator system dynamics (piston dynamics)

Applying the second Newton law for each mass and considering the friction of the hydraulic cylinder results in,

$$\ddot{X} = \frac{1}{M}(P_1 A_1 - P_2 A_2 - F_f) \quad (1)$$

where the unknown parameter (X) is the position of the mass load (piston load), (M) is the mass of the piston load, and (P<sub>1</sub>) and (P<sub>2</sub>) are the pressures of the hydraulic cylinder of chamber 1 and chamber 2, respectively. Friction (F<sub>f</sub>) in the hydraulic cylinder is taken into account as an external force.

The friction equations as represented by LuGre model are defined by, [4,5,6]

$$\frac{dz}{dt} = \dot{X} - \frac{|\dot{X}|}{g(\dot{X})} z \quad (2)$$

$$g(\dot{X}) = \frac{1}{\sigma_0} \left( F_c + (F_s - F_c) e^{-\left(\frac{\dot{X}}{V_s}\right)^2} \right) \quad (3)$$

$$F_f = \sigma_0 z + \sigma_1 \frac{dz}{dt} + k_v \dot{X} \quad (4)$$

where  $\dot{X}$  (m/s) is the piston velocity, and F<sub>f</sub> (N) is the friction force described by the linear combination of (z), (dz/dt) and the viscous friction. Equation (4) represents the dynamics of the friction. The parameter (z) in friction equations is an internal state, not the system's state, so the parameter is only used to calculate the friction of a hydraulic cylinder. The function g( $\dot{X}$ ) describes Part of the "steady- state" characteristics of the model for constant velocity motions: V<sub>s</sub> is the Stribeck velocity, F<sub>s</sub> is the static friction, F<sub>c</sub> is Coloumb friction, and k<sub>v</sub> is the viscous friction. Thus, the complete friction model is characterized by four static parameters and two dynamic parameters, the stiffness coefficient (σ<sub>0</sub>) and damping coefficient (σ<sub>1</sub>).

**2.2 The cylinder chamber pressure**

The pressure rate equations are yielded by applying the flow continuity equations for the servo-valve in volume between the orifices and their outlets as shown in equations [5, 6] below:

$$\dot{P}_1 = \frac{\beta e_1}{V_1} (Q_1 - A_1 \dot{X} + Q_{Li} - Q_{Le1}) \quad (5)$$

$$\dot{P}_2 = \frac{\beta e_2}{V_2} (-Q_2 + A_2 \dot{X} - Q_{Li} - Q_{Le2}) \quad (6)$$

where  $(Q_{Li})$  is internal leakage flow  $(Q_{Le1})$  and  $(Q_{Le2})$  are the external leakage flows of the valve ports,  $(A_1)$  and  $(A_2)$  are the areas of the piston for chamber 1 and chamber 2 respectively,  $(V_1)$  and  $(V_2)$  are the volume between each side of the piston and the servo-valve, and parameters  $(\beta e_1)$  and  $(\beta e_2)$  are the bulk modulus of the hydraulic fluids in each side of the piston, respectively.

The volumes between the valve and each side of the piston are calculated as,

$$\begin{aligned} V_1 &= A_1 X + V_{o1} \\ V_2 &= A_2 (L - X) + V_{o2} \end{aligned} \quad (7)$$

Where  $(V_{o1})$  and  $(V_{o2})$  are volumes at ports one and two, respectively and  $L$  is the stroke length.

**2.3 Valve flow - pressure**

The non-linear equations of valve flows are usually described by the orifice equations with a linear relationship between the valve spool position,  $(X_s)$  and the flow area (critical center) as follows,

$$Q_1 = \begin{cases} C_s X_s \sqrt{P_s - P_1} & U \geq 0 \\ C_s X_s \sqrt{P_1 - P_t} & U < 0 \end{cases} \quad (8)$$

$$Q_2 = \begin{cases} C_s X_s \sqrt{P_2 - P_t} & U \geq 0 \\ C_s X_s \sqrt{P_s - P_2} & U < 0 \end{cases} \quad (9)$$

Where  $(P_s)$  and  $(P_t)$  are the supply and tank pressure, respectively, and the unknown parameter  $(C_s)$  is a parameter including discharge coefficient and fluid density.

**2.4 Valve spool dynamics**

To be able to represent servo-valve approximation dynamics through a wider frequency range, a first or second order transfer function is used. For low frequencies (up to about 50 Hz), a first order approximation may be sufficient. The relation between spool position  $(X_s)$  and the input voltage  $(U)$  can be written as,

$$G_v(s) = \frac{X_s}{U} = \frac{\tau_1}{s + \tau_2} \quad (10)$$

The two unknown parameters are  $(\tau_1)$  and  $(\tau_2)$ .  $(\tau_1)$  is the value of gain and  $(\tau_2)$  is a time constant.

**3. Nonlinear Modeling of Servo Hydraulic Circuit**

The nonlinear modeling of the servo hydraulic system is introduced using MATLAB\Simulink program. The Simulink model will solve the nonlinear equations numerically, and provide a simulated response of the system dynamics. The proposed Simulink nonlinear model for a hydraulic circuit with servo valve is shown in figure (2) and the internal blocks of the hydraulic system are shown in figure (3), figure (4), figure (5) and figure (6) respectively.

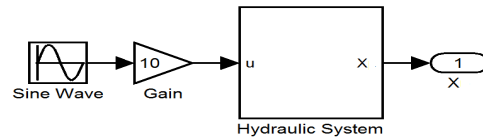

Figure (2) Simulink nonlinear model of servo hydraulic system.

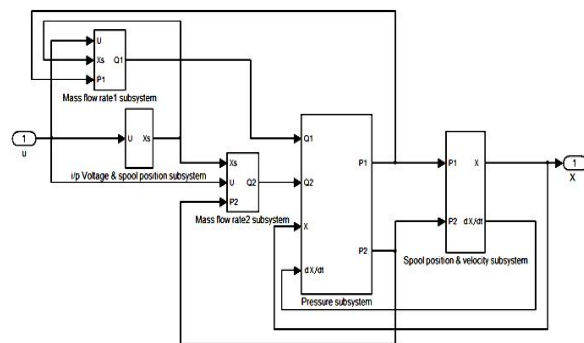

Figure (3). Internal block of hydraulic system.

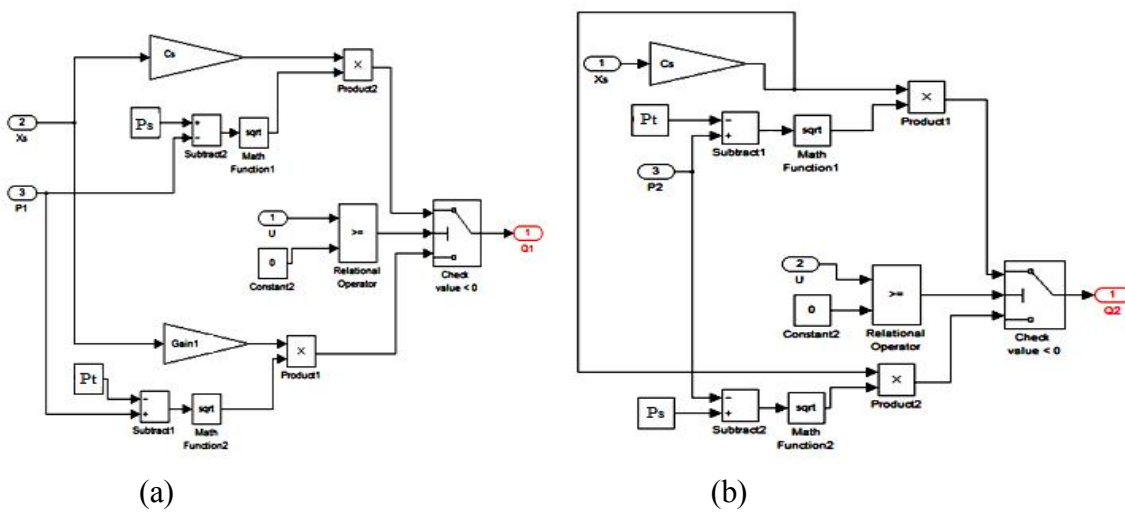

Figure (4). (a) The flow rate at chamber one  $Q_1$ .  
(b) The flow rate at chamber two  $Q_2$ .

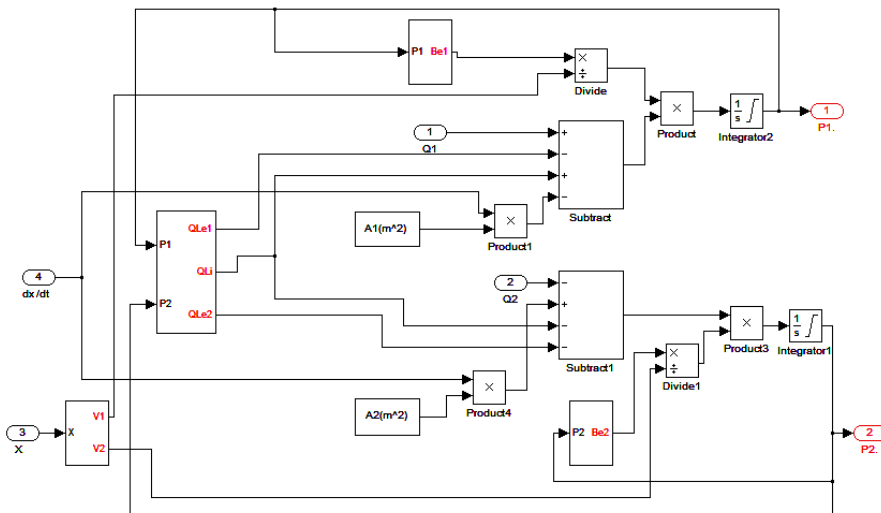

Figure (5) the pressure of both chamber one and two ( $P_1$  &  $P_2$ ).

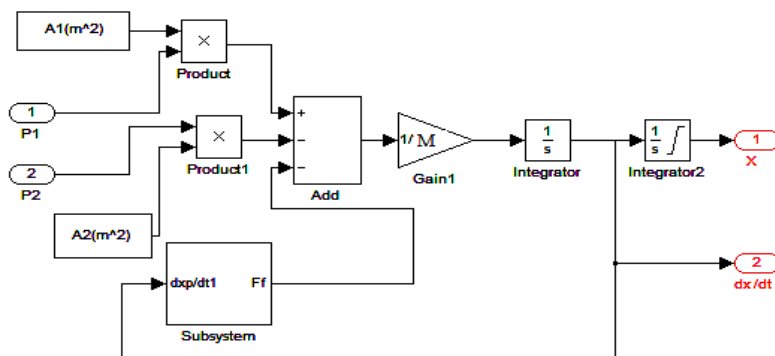

Figure (6). The piston displacement ( $x$ ) and velocity ( $dx/dt$ ).

To simulate the Simulink model of servo hydraulic system, a double acting single rod cylinder from Bosch Rexroth Company will be used. The internal dimensions of: radius of chamber 1 is 32 mm, radius of chamber 2 is 22 mm and with stroke length 1m.[6]

Moreover, the valve used in this system is selected to be a Bosch Rexroth servo solenoid valve with On -Board Electronics (OBE). It is a control application valve with **Type 4WRPE**, where the acceleration and velocity are controlled by valves switching techniques. The relationship between the mass flow rate and the input voltage is shown in figure (7) [13].

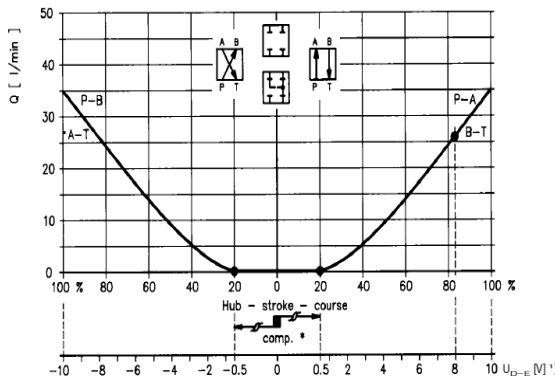

Figure (7) The relationship between the mass flow rate and the input voltage [13].

By applying the parameters shown in table (1)[6] and variable voltage changes from (10 to - 10) V as a sinusoidal function, the input voltage to the valve and the response of the open loop displacement (x); which is measured using either a position sensor or by a linear potentiometer that record the position of the cylinder rod; is shown in figure (8) and figure (9) respectively, while the pressure increase in chamber 1 and its decrease in chamber 2 according to the movement of the cylinder are shown in figure(10).

Table (1) The basic simulation parameters

Parameter	Value
Area 1 (A1)	$8.04 * 10^{-4} \text{ m}^2$
Area 2 (A2)	$4.24 * 10^{-4} \text{ m}^2$
Mass (M)	210 kg
Length of piston (L)	1 m
Supply pressure ( $P_s$ )	14 MPa
Tank pressure ( $P_t$ )	0.9 MPa
Columbic friction( $F_c$ )	247.804 N
Static friction ( $F_s$ )	7485.084 N
Viscous friction ( $K_v$ )	376.613 Ns/m
Stribeck velocity ( $V_s$ )	0.026318 m/s

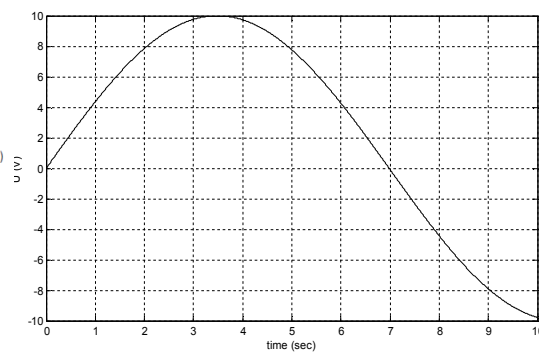

Figure (8). The input voltage (u).

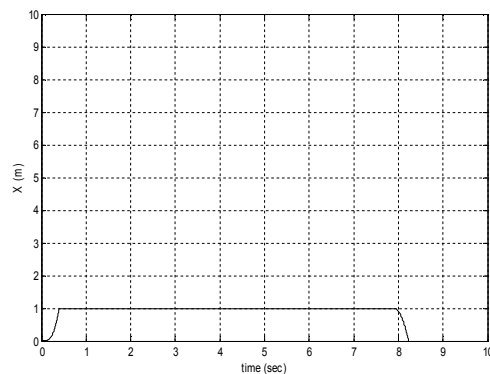

Figure (9). The open loop actual displacement (x) response.

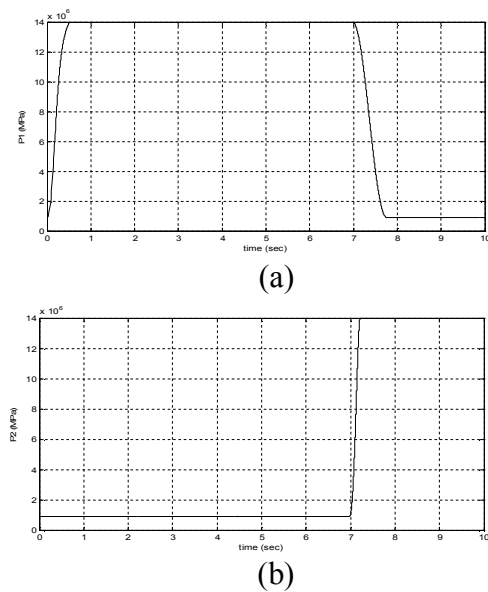

Figure (10). The pressure response of (a) chamber1 and (b) chamber 2.

**4. Design and Tuning PID Controller Using G.A. Tool**

In the control of dynamic systems, no controller has enjoyed both the success and the failure of the PID control. Of all control design techniques, the PID controller is the most widely used. Over 85% of all dynamic controllers are of the PID variety. There is actually a great variety of types and design methods for the PID controller [14]. The continuous form of the PID, which is Proportional – Integral -Differential controller equation, is:

$$u(t) = K_p \cdot e(t) + K_i \cdot \int_0^t e(t) dt + K_d \cdot \frac{de(t)}{dt} \tag{11}$$

Where  $K_p$  is the proportional gain,  $K_i$  is the integral gain and  $K_d$  is the derivative gain and the error signal is:

$$e(t) = x_d(t) - x(t) \tag{12}$$

Where  $e(t)$  is the error signal,  $x_d(t)$  is the desired output and  $x(t)$  is the actual output. The Simulink model

representation of the controller is shown in figure (11). By connecting the PID controller to the hydraulic model mentioned above, the Simulink model of the closed loop controlled system is shown in figure (12).

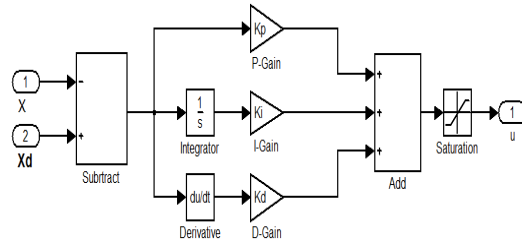

Figure (11). Simulink model of PID controller.

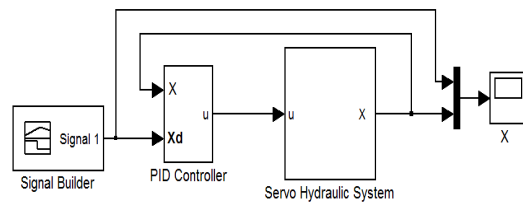

Figure (12) Simulink model of PID controller with servo hydraulic system.

By tuning the parameters of the controller to achieve cylinder position with minimum steady state error, it was found after several trials that the parameters of the controller are to be  $K_p=30$ ,  $K_i=20$  and  $K_d=44$ . The output of the cylinder is shown in figure (13). The steady state error ratio is found to be 4.5 %. However, the controller output is shown in figure (14).

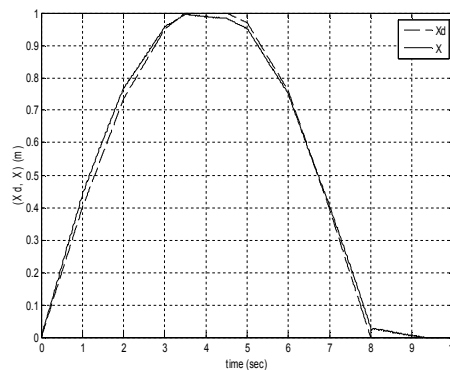

Figure (13). Simulation of PID controller for servo hydraulic system.

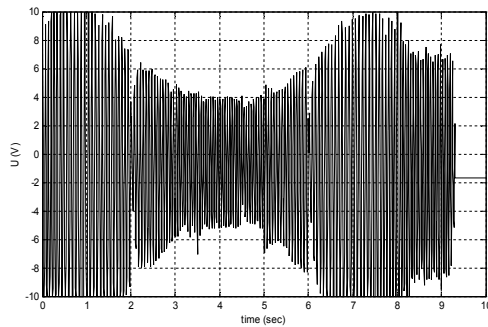

Figure (14). Output of the controller u .

### 5. Genetic Algorithm Technique

It is known that PID controller is employed in every facet of industrial automation. The applications of the PID controller span from small industry to high technology industry. For those who are in heavy industries such as refineries and ship-buildings, working with PID controller is like a routine work. Hence how do we optimize the PID controller? Do we still tune the PID the way we were used to, for example, using the classical technique that has been taught to us? Or do we make use of the power of computing world by tuning the PID in a stochastic manner? In this paper, it is proposed that the controller be tuned using the Genetic Algorithm technique. Genetic Algorithms (GAs) are a stochastic global search method that emulates the process of natural evolution. Genetic Algorithms have been shown to be capable of locating high performance areas in complex domains without experiencing the difficulties associated with high dimensionality or false optima as may occur with gradient decent techniques. Using genetic algorithms to perform the tuning of the controller will result in the optimum controller being evaluated for the system every time [15, 16].

A genetic algorithm (GA) is a robust optimization technique based on natural selection. The basic goal of GA is to optimize functions called fitness functions. GA based approaches differ from conventional optimization methods in several ways. First, GA searches work with a coding of the parameter set rather than the parameters themselves. Second, GA searches from a population of points rather than a single point. Third, GA uses payoff (objective function) information, not other auxiliary knowledge. Finally, GA uses probabilistic transition rules, not deterministic rules. These properties make GA robust, powerful, and data-independent.

In this paper we first extract the transfer function of the servo hydraulic system and then use it to determine the best fitness by using GA technique as shown in figure (15) below:

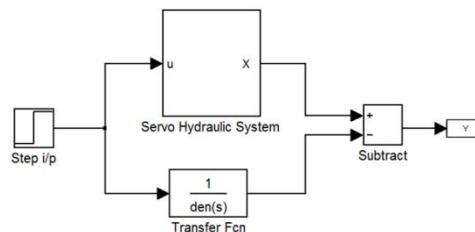

Figure (15). The circuit of finding the transfer function of hydraulic servo system.

The transfer function parameters are manually tuned until the output (Y) [Y is the measured error] is equal to zero where the transfer function will describe the linear representation of the servo hydraulic model.

$$G(s) = \frac{1}{0.00008 s^2 + 0.009 s + 1}$$

Where is this 2<sup>nd</sup> order transfer function used in GA program and by



using the GA tool in MATLAB we find the best fitness of (KP, KI and KD) to use these gains in PID controller to enhance the output of the servo hydraulic system and here below the GA program which is done using the Runge -Kutta stages method that is represented by the stages in the flow chart below shown in figure (16), see appendix (A).

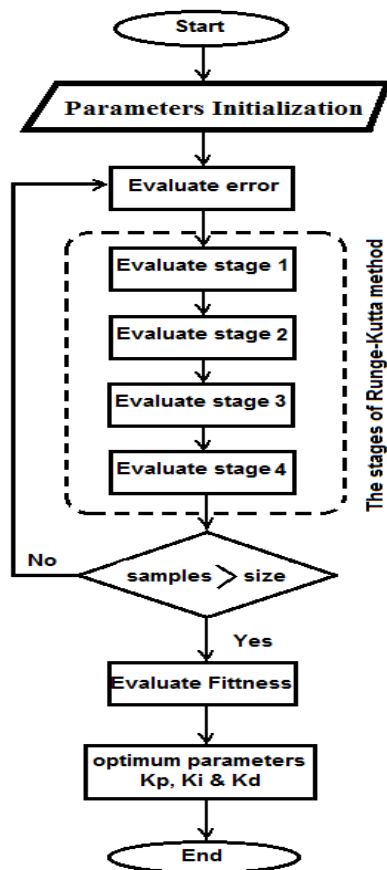

Figure (16). Flow chart of G.A. functions and process.

After using the gains obtained from the GA tuned program where (KP=26, KI=8 and KD=10) the enhanced output will be as shown in figure (17) and the control unit shown in figure (18)below where the error will be improved as it was in the use of the gains of classical PID controller to be (2.5)%.

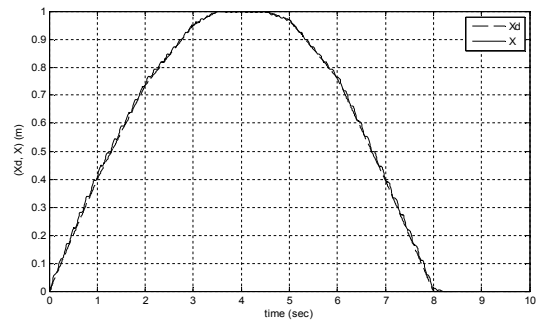

Figure (17). Simulation of PID controller for servo hydraulic model using gains obtained from GA technique.

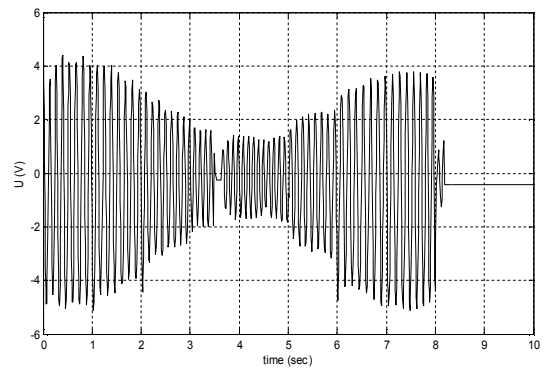

Figure (18). Output of the PID controller (u)

Based on the error analyses, control effort and observation on the tracking performance, the PID controller after tuning it's parameters with G. A. tool provides more convenient and better performance in position tracking control as shown in Table (2):

Table(2):Results of the steady state error.

Controller	error%
Classical PID controller	4.5 %
PID controller after using G.A tool	2.5 %

It can be concluded from the results above that the PID controller parameter tuned by using G.A. tool has improved the error of the system's response as compared with the error of the PID controller with manually tuning its parameters by 44.44 %. The output does not reach the zero error because of the nonlinearity of the servo hydraulic system model.

## 6. Conclusions

In this study, a nonlinear modeling for the servo hydraulic system is represented by using mathematical equations with the assistance of Matlab program; taking into considerations the nonlinearities of the hydraulic system; such as different friction forces, internal and external leakage flow and the bulk modulus of the hydraulic fluids.

The open loop response shows a higher steady state error. In order to improve the steady state error, a PID controller has been used in the following two ways:

The first one: The controller parameters were manually tuned.

The second one: using the Genetic Algorithm technique as a tool to tune the PID controller parameters.

By comprising the above two values obtained by applying the two methods, it has been noticed that the numerical simulation study shows that the proposed PID controller provides better performance in tracking accuracy of the steady state error.

Consequently, we can benefit from the results we obtained in the future projects when we try to use another type of controllers (for example, neural controller, sliding mode controller, fuzzy controller ...etc) in order to reduce the error percentage and to improve the steady state error.

## References

- [1] Zulfatman and M. F. Rahmat, "Application of Self-Tuning Fuzzy PID Controller On Industrial Hydraulic Actuator Using System Identification Approach", *International Journal On Smart Sensing and Intelligent Systems*, Vol. 2, NO. 2, JUNE 2009.
- [2] V. Pastrakuljic, "design And Modeling Of A New Eleicro HydraulicActuator", thesis, National Library of Canada, 1995.
- [3] A. AIROUCHE, H. AKNOUCH and A. Reinhorn, "Mechanical Model of Servo-Hydraulic-System", CIE616.
- [4] M. Mihajlov, V. Nikolić, and D. Antić, "Position Control Of An Electro-Hydraulic Servo System Using Sliding Mode Control Enhanced By Fuzzy PI Controller", *FACTA UNIVERSITATIS, Mechanical Engineering Vol.1, No 9, 2002*, pp. 1217 – 1230.
- [5] H. Yousefi, "On Modelling, System Identifi cation and Control of Servo-Systems with a Flexible Load", Ph.D. Thesis Acta Universitatis Lappeenrantaensis, 2007.
- [6] H. Yousefi , H. Handroos and A. Soleymani , " Application of Differential Evolution in system identification of a servo-hydraulic system with a flexible load", *Institute of Mechatronics and Virtual Engineering, Department of Mechanical Engineering, Lappeenranta University of Technology, Lappeenranta, Finland, Mechatronics 18 (2008) 513–528.*
- [7] I. Algelli, S. Ehtiwesh, and Ž. Đurović , "Comparative Analysis of Different Control Strategies for Electro-hydraulic Servo Systems", *World Academy of Science, Engineering and Technology 56 2009.*
- [8] T.M. Menshawy, M. A. Moghazy , A. H. Lotfy, " Investigation of

- Dynamic Performance of an Electro-Hydraulic Proportional System", 13th International Conference on aerospace sciences & aviation technology, asat-13, May 26 – 28, 2009.
- [9] D. Maneetham and N. Afzulpurkar, "Modeling, simulation and control of high speed nonlinear hydraulic servo System", England, UK World Journal of Modelling and Simulation, Vol. 6 (2010) No. 1, pp. 27-39.
- [10] Gregov, G. & Siminiati, D. "Computer Simulation Of A Laboratory Hydraulic System With Matlab-Simulink", Advanced Engineering, 4(2010)1, ISSN 1846-5900.
- [11] C. H. Corteline and L. S. Góes, "On the Air in Servo Valve Hydraulic Control Systems", Proceedings of the 9th Brazilian Conference on Dynamics Control and their Applications, June 7-11, 2010.
- [12] Y. Jiangang, L. Zan, "An Improved Digital PID Algorithm for Angle Position Electric-hydraulic Servo System", International Journal of Digital Content Technology and its Applications. Volume 5, Number 4, April 2011.
- [13] Bosch Rexroth AG Industrial Hydraulics, "4/3 servo solenoid valves with on-board electronics (OBE), positive overlap and position feedback", Lohr am Main, Germany, 2005. [www.boschrexroth.de](http://www.boschrexroth.de)
- [14] Robert A. Paz, "The Design of the PID Controller", Klipsch School of Electrical and Computer Engineering June 12, 2001.
- [15] S. B. M. IBRAHIM, "The PID Controller Design Using Genetic Algorithm", University of Southern Queensland Faculty of Engineering and Surveying, Submitted: 27th October, 2005.
- [16] C. Khamsum, S. Pothiya, C. Taowklang and W. Sa-ngiamvibool, "Design of Optimal PID Controller using Improved Genetic Algorithm for AGC including SMES Units", GMSARN International Conference on Sustainable Development: Issues and Prospects for GMS 6-7 December 2006.

### Appendix (A)

The m-file program of the PID controller parameters tuning using genetic algorithm tool:

```
function fit=mus2(r)
x1=0;x2=0;x3=0;x4=0;
kp=r(1); ki=r(2); kd=r(3);
h=0.01; e=0; ise=0; y=0;
for i=0:1:1000
    e=1-y;
    a1=h*x2;
    b1=h*x3;
    c1=h*x4;
    d1=h*(e-(112.5*x3)-(12.5*x2));
    a2=h*(x2+(b1/2));
    b2=h*(x3+(c1/2));
    c2=h*(x4+(d1/2));
    d2=h*(e-(112.5*x3)-(112.5*(c1/2))-
    (12.5*(x2+(b1/2))));
    a3=h*(x2+(b2/2));
    b3=h*(x3+(c2/2));
    c3=h*(x4+(d2/2));
    d3=h*(e-(112.5*x3)-(112.5*(c2/2))-
    (12.5*(x2+(b2/2))));
    a4=h*(x2+b3);
    b4=h*(x3+c3);
    c4=h*(x4+d3);
    d4=h*(e-(112.5*(x4+d3))-
    (12.5*(x2+b3)));
    x1=x1+(a1+(2*a2)+(2*a3)+a4)/6;
    x2=x2+(b1+(2*b2)+(2*b3)+b4)/6;
    x3=x3+(c1+(2*c2)+(2*c3)+c4)/6;
    x4=x3+(d1+(2*d2)+(2*d3))+d4/6;
    ise=ise+(e*e*h);
    y=12.5*((kd*x3)+(kp*x2)+(ki*x1));
end fit=-1/ise;
```