



BEHAVIOR OF RECYCLED AGGREGATE CONCRETE BEAMS STRENGTHENED WITH FRP

Amera H. Ftnan¹ and Ragheed F. Makki²

¹ M.Sc. Student, College of Engineering, University of Kufa, Najaf, Iraq. Email:
amerahakm@gmail.com ; amarahakim@student.kufa.edu.iq

² Professor, Ph.D., College of Engineering, University of Kufa, Najaf, Iraq. Email:
Ragheed.almutwali@uoKufa.edu.iq

<https://doi.org/10.30572/2018/KJE/130402>

ABSTRACT

In this paper, the experimental work of this research included the test of seven concrete beams with dimensions (0.24 * 0.15 * 1.7) m. The mixing ratio is (1:2:3) and the water ratio(w/c) is 0.5. The first control beam has new aggregates and without strengthen with carbon fiber polymer sheet. The next three beams have the different ratio of recycled aggregate of (25%, 50%, 75%), and the last three beams have the different ratio of recycled aggregate of (25%, 50%, 75%) and with strengthen with carbon fiber polymer sheet. The experimental results showed that the ultimate load in the control beam (NC) became approximately (4,9,14) % respectively higher than the group of the recycle aggregate (B2. B3. B4) beams. When strengthening the beams by carbon fiber polymer sheet. The author notice the ultimate load in the control beam (NC) became approximately (20,16,0) % respectively lesser than the group of recycle aggregate (B5.B6.B7) strengthening beams.

KEYWORDS: Recycled Aggregate Concrete, Carbon fiber polymer sheet

1. INTRODUCTION

Recycled aggregate (RA) is taken from building crushing and Demolition waste. It may be defined as Recycled Concrete Aggregate (RCA) when it is crushed concrete or more Aggregate generally recycled (RA) or containing large amounts of materials other than crushed concrete (Standard, 2006). It is more than construction waste by 65%. Almost, about 73% of this demolished concrete and aggregated materials are recycled as shown in Fig. 1 (Nitivattananon and Borongan, 2007). The crushed gravel from the used concrete blocks was taken from the rubble of old buildings and crushed manually by workers with a range of 5 to 19 mm, and it was used for specific samples at rates of 25%, 50% and 75% of the proportion of new aggregates within the concrete mixtures according to the Iraqi.

Specifications (IQS No. 45/1984) and compared with the Iraqi specifications limits (Hajer, 2013). The aim of this research is to study an experimentally using recycled aggregate in different proportions to obtain an economic beam with good resistance. As well as to reduce environmental pollution from waste tires and old building debris. As well as the extent of the effect of strengthening concrete beams with (CFRP) and comparing it with ordinary concrete beams reinforced with the same sheet carbon. In (2018) In Australia, over 3 million tons of waste rubble-largely concrete- It has resulted annually. Approximately 50% of the material is recycled as an RCA and the remnant is sent to landfills (Cao, 2020). Worldwide research has found that there exists clear dissimilarity between properties of recycled coarse aggregates (RCA) and those of natural coarse aggregates (NCA), as porosity and water absorption, reduce surface density, and increase crush value. According to the specific performance Conditions of concrete, choosing Suitable basic materials, then Design low cost and high quality concrete based on the appropriate mixing ratio is the best way to overcome the needs of the traditional design methods, and this puts forward new thoughts and design way (Xiao, 2018). In (2020) Sixteen full-scale recycled aggregate concrete (RAC) beams, it was subjected and tested for their time-dependent behavior under long-term loading. Test parameters include the replacement rate for recycled coarse aggregate (RCAs), the replacement rate for fine recycled aggregate (RFAs), concrete strength, and stress ratio. The results show that RCAs will raise the sample deflection at a reduced strain ratio; at increase-stress ratio, the beams will test nonlinear creep, and the deflection of the specimen will be influenced by the RCAs and the stress ratio. The RFAs have a substantial effect on the time-dependent behavior of the specimen, and the deflection of the specimen with 100% replacement of recycled aggregates can raise by 30% (Cao, 2020). In 2020. An experimental study is presented to verify the bending performance and

instantaneous redistribution ability of continuous (dual-span) RC beams reinforced with carbon fiber reinforced polymer (CFRP) strips. In order to avoid sudden failure and improve the load capacity and instantaneous redistribution, as well as ductility, the final clamping mechanism is proposed. Here, four continuous girders of 6000 mm in length with sections of 250 × 150 mm were constructed. The results obtained showed that the proposed anchor use of CFRP segments in continuous beams caused a significant increase in the loading capacity, instantaneous redistribution ratio, and ductility (Bengar and Shahmansouri -2020). In 2021, a bending test was performed on a four-point light beam to verify the structural behavior, where a characteristically high structural efficiency, 56 N/g, was successfully achieved. The additional pre stressing has been determined to be able to increase the bending strength of the beam by up to 15%. The increase in bending strength is due to the improved stress distribution of the compressive beam. The proposed CFRP beam, with its very light weight and high load-bearing strength, can be relied on for a wide range of practical developments and applications, especially where high structural efficiency is required (Zhang, 2021).

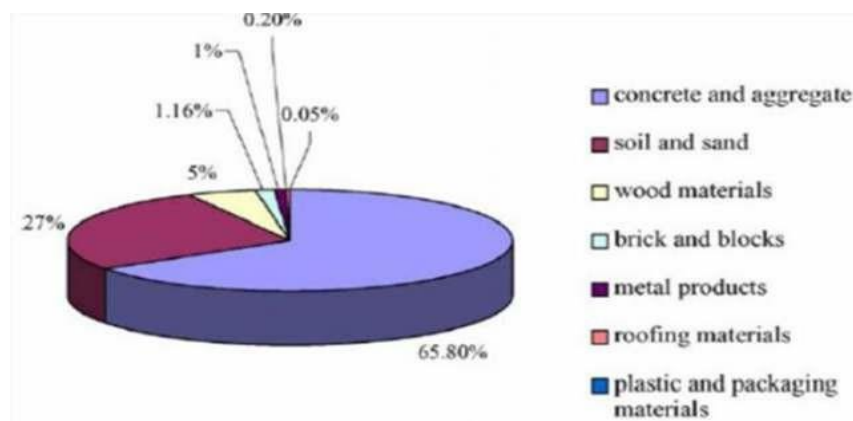

Fig. 1. Composition of generated construction waste materials (Hajer, 2013).

Seven simply supported beams specimens were strengthened with a longitudinal reinforcements 2 in the tension area and with a hook at its ends connected by a longitudinal reinforcements for the compression area with the wire and 2 in the compression area with a diameter of 12 mm. 12 stirrups was placed with a diameter of 10 mm, vertically and a distance of 10 cm to prevent shear Failure and initiate bending failure. The space between the supports was 150 cm and the distance between the point of loading (P1, P2) was 50 cm as shown in Fig. 2.

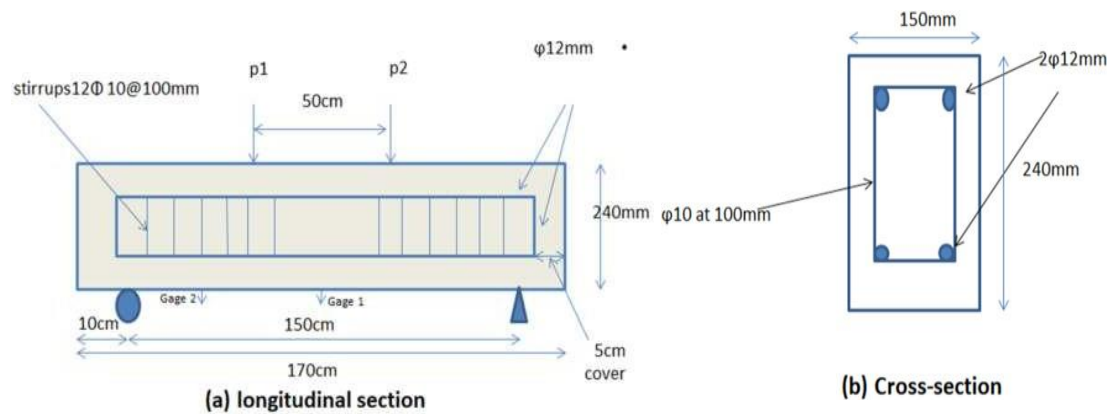

Fig. 2. The details of specimens and test setup.

2. CONCRETE MIXES

The concrete materials were mixed manually in a large basin, after their quantities were measured before mixing with an electronic in accordance with the mix design as tabulated in Table 1. Both recycled and natural aggregate were passed through a sieve No. 19 to obtain this gradient, water was added at a ratio of 0.5 Increases with increasing recycled aggregate to 0.65 water added foreach mixture for one beam and the components that are in a mixing ratio (1.2.3) are mixed until the mixture is homogeneous and becomes one color, and then the pouring phase begins in the wooden molds and is stacked with vibrators The electrode is for three layers and equals the surface as for the other 3 beams, have been reinforced with carbon fiber polymer(CFRP) sheets from the bottom

Table 1. a: Description of Test the seven beams with reinforced with carbon fiber polymer (CFRP) sheets from the bottom.

Mixes	Beam number	Cement (kg/m ³)	FA (kg/m ³)	CA (kg/m ³)	RCA (kg/m ³)	Failure Load Pu(KN)	Strengthen with (CFRP) case
NC	1	348	696	1044	0	120	Without strength
Recycle aggregate %	25%	348	696	783	261	115	
	50%	348	696	522	522	110	
	75%	348	696	261	783	105	
Recycle aggregate %	25%	348	696	783	261	145	With strength
	50%	348	696	522	522	140	
	75%	348	696	261	783	120	

3. TEST MEASUREMENTS AND INSTRUMENTATION

In the structural laboratory of the College of Engineering at the University of Kufa, all specimens of reinforced concrete beams were tested using a hydraulic machine (universal machine) with a maximum range capacity of 2000 kN as shown in Fig. 3. The beam specimens were withdrawn from the water at the age of twenty-eight days, cleaned, and painted so that cracks could be easily detected before the testing day. Bearing plates (150mm x 150mm x 16mm) were installed at both ends of the beam to distribute the load over the cross-section, as shown in Fig. 2. During the casting process, these plates were inserted in the ends of the beams. They were attached to keep the beam from moving to the side during the test. There were no gaps between the plate and the concrete. Two dial gauges were fitted when the specimen was placed on the hydraulic machine, one in the middle of the beam and the other in a quarter of the beam length. The load shedding is gradual, increasing every 5 kn for each stages as shown in Fig. 3.



Fig. 3. The Testing of beams specimens.

4. CARBON SHEET (CFRP)

The Sika Wrap®-300 C is a unidirectional woven carbon fiber fabric may only be used by experienced professionals. Structural strengthening of reinforced concrete, masonry, brickwork and timber elements or structures, to increase flexural and shear loading capacity for:

- Improved seismic performance of masonry walls
- Replacing missing steel reinforcement
- Increasing the strength and ductility of columns
- Increasing the loading capacity of structural elements Enabling changes in use / alterations and refurbishment

5. EPOXY

Sikadur®-330 is a two-component, solvent-free, moisture-tolerant, high strength, high modulus structural epoxy adhesive. USES Sikadur®-330 may only be used by experienced professionals. For use as an impregnating resin with the SikaWrap® Hex 106G, 113C, 117C, 230C and 430G Structural Strengthening Systems.

6. STRENGTHENING OF BEAMS WITH (CFRP)WORKS

At first the smoothing the Bottom layer of the beam with electrical ten of the beams have been strengthened with carbon reinforced sheets, where the lower side of the beam is coated with epoxy as a first layer and the second layer of epoxy is applied to the carbon sheet and rolling roller after sticking the sheet carbon to the beams as shown in the [Plate 1](#).



Plate 1. Strengthening of beams with (CFRP)works.

7. RESULTS AND DISCUSSION

7.1. The beam Control Specimen NC

The failure occurred at the ultimate load and deflection, are 120kN and 12.566mm respectively.as in [Plate 2](#) and [Fig. 4](#).



Plate 2. Cracks Pattern of CB.

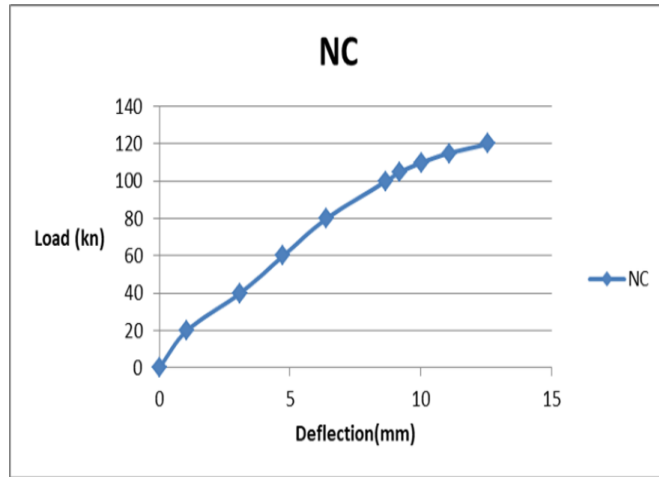

Fig. 4. Load-Deflection Curve of NC.

7.2. GROUP (1) Flexural Results of recycle aggregate Beams (RCA)

Several states have been tested

- a. Beam (B2. RCA25%): The failure occurred at the ultimate load and deflection, are 115kN and 12.18mm respectively, it was less by 5 kN, 0.386mm from (NC) as in Plate 3. Because 25% of the natural aggregate was replaced with recycled aggregate, the load in the beam (NC) became approximately 4% higher than the (B 2. RCA 25 %) beam as shown in Fig. 5.

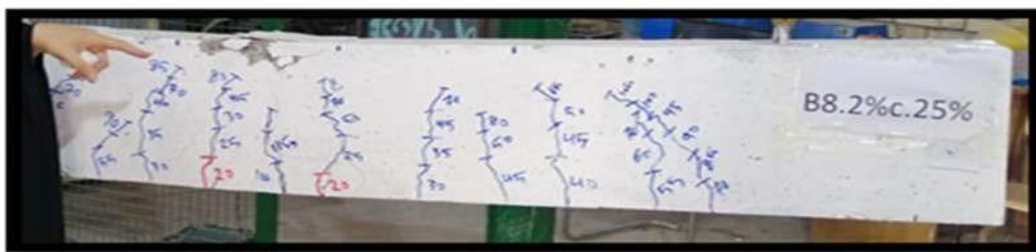

Plate 3. Cracks Pattern of (B2. RCA 25%).

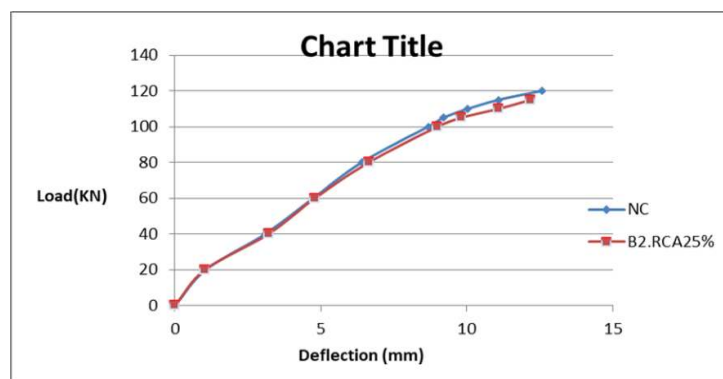

Fig. 5. Load-Deflection Curve of (NC) and (B2.RCA 25%).

- b. Beam (B3. RCA 50 %): The failure occurred at the ultimate load and deflection, are 110kN and 11.7mm respectively, it is less by 10kN ,0.866mm respectively from (NC)as in [Plate 4](#). Because 50% of the natural aggregate was replaced with recycled aggregate, the load in the beam (NC) became approximately 9% higher thanthe (B3.RCA 25%) beam as shown in [Fig. 6](#).

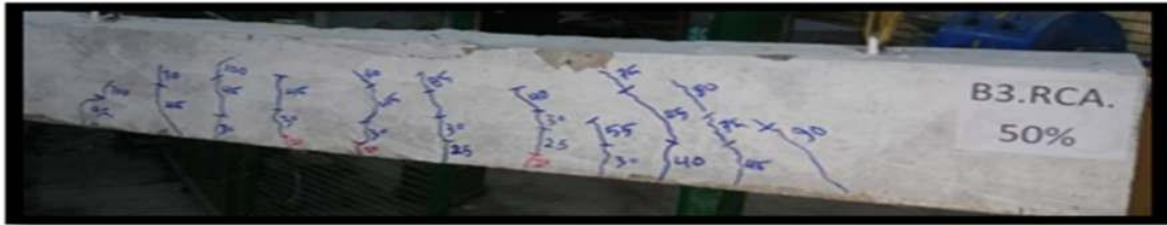

Plate 4. Cracks Pattern of (B3. RCA50%).

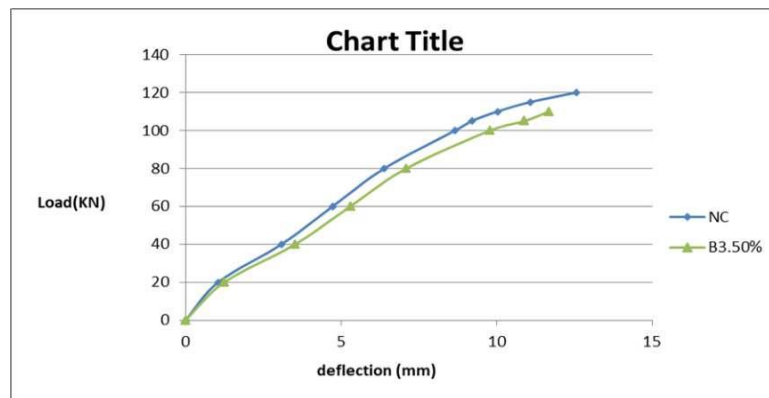

Fig. 6. Load-Deflection Curve of (NC)and (B3. RCA50%).

- c. Beam (B4. RCA75%): The failure occurred at the ultimate load and deflection, are 105kN and 11.3mm respectively, it is less by 15 KN ,1.266mm respectively from (NC)as [Plate 5](#). Because 75% of the new aggregate was replaced with recycled aggregate, the load in the beam (NC) became approximately 14% higher than the (B4. RCA75%) beam as shown in [Fig. 7](#).

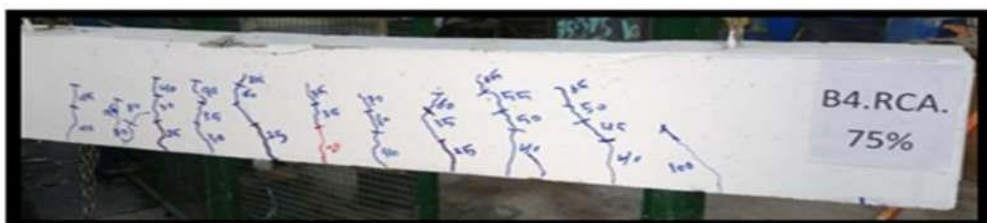

Plate 5. Cracks Pattern of (B3. RCA75%).

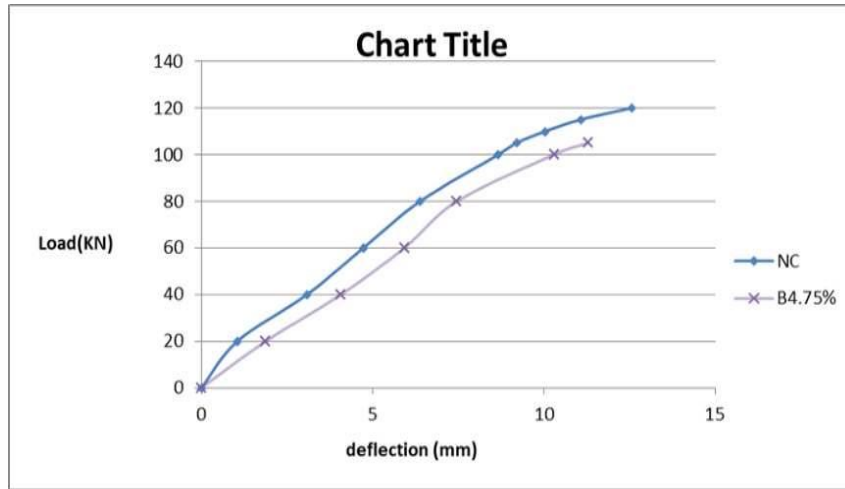

Fig. 7. Load-Deflection Curve of (NC)and (B4. RCA75%).

7.3. Group (2) Flexural Results of recycle aggregate Beams (RCA) strengthening

- a. Beam (B2. RCA25%)S: The failure occurred at The ultimate load and deflection, are 145kN and 13mm, it is more by 25KN,0.434mmfrom(NC) as in Plate 6. Due to the beam (B2. RCA25%) strengthen with the carbon sheet, the load in the beam (B2. RCA25%) is approximately 20% higher than in the beam (NC) as shown in Fig. 8.



Plate 6. Cracks Pattern of (B2. RCA25%)S.

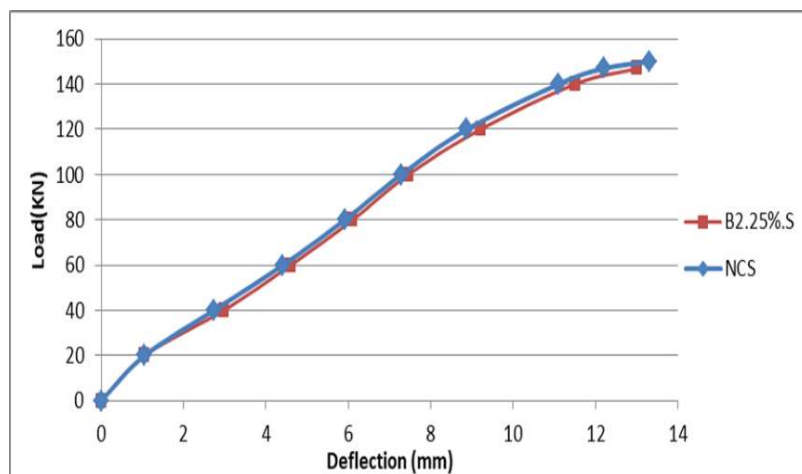

Fig. 8. Load-Deflection Curve of (NC) beam and the (B2. RCA25%)S strengthen.

- b. Beam (B3. RCA50%S) The failure occurred at the ultimate load and deflection, are 140kN and 12mm, it is more by 20kN, and it is less by 0.566mm respectively from (NC) as in [Plate 7](#). Due to the beam (B3. RCA50%S) strengthen with the carbon sheet, the load in the beam (B3. RCA50%S) is approximately 16% higher than in the beam (NC) as shown in [Fig. 9](#).



Plate 7. Cracks Pattern of (B3. RCA50%S).

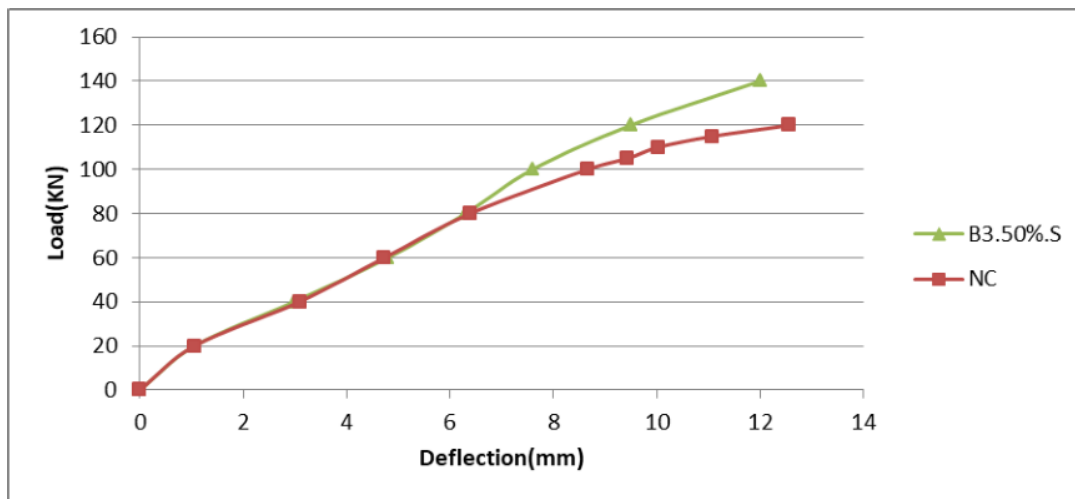

Fig. 9. Load-Deflection Curve of (NC) beam and the (B3. RCA50%S) strengthen.

- c. Beam (B4. RCA75%S): The failure occurred at the ultimate load and deflection, are 120kN and 10.9 mm, it is same force with (NC) beam as in [Plate 8](#). Due to the beam (B4. RCA75%S) strengthen with the carbon sheet, the load in the beam (B4. RCA75%S) is equal to the beam (NC) as shown in [Fig. 10](#).

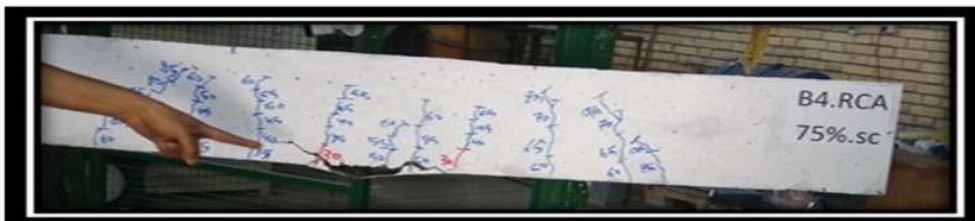

Plate 8. Cracks Pattern of (B4. RCA75%S).

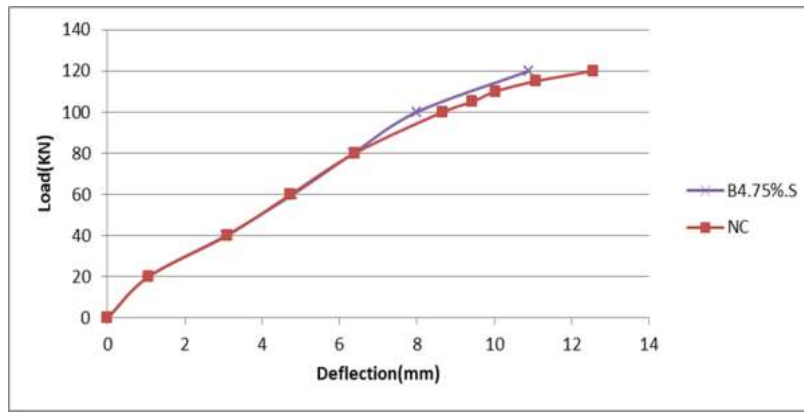

Fig. 10. Load-Deflection Curve of (NC) beam and the (B4. RCA75%S) strengthen.

Because (25,50,75%) respectively of the new aggregate was replaced with recycled aggregate, the load in the beam (NC) became approximately (4,9,14) % respectively higher than the (B2. B3. B4) beam .Due to the beams(B2.B3.B4)strengthen with the carbon sheet, the load in the beam (B2.B3.B4) strengthen is approximately (26,27,14)%respectively higher than in the beam (B2.B3.B4) without strengthen and the load in the beam (B2.B3) strengthenhigher than in the beam(NC) as shown in Fig. 11.

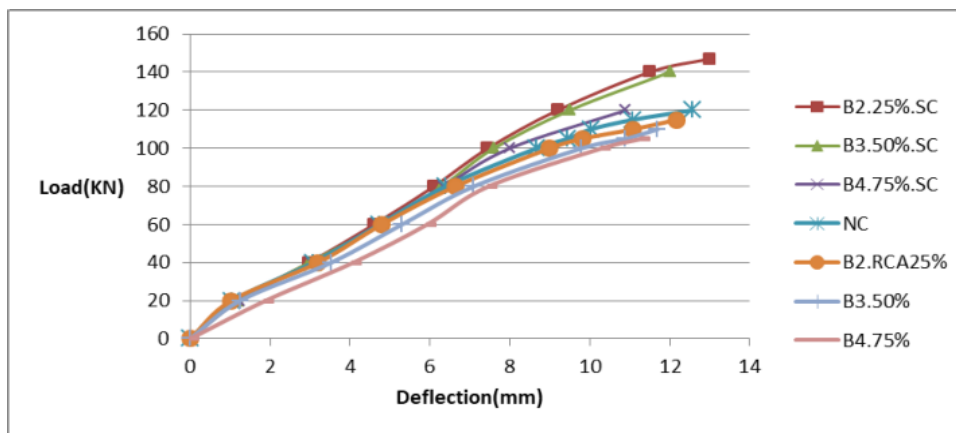

Fig. 11. Load-Deflection Curve of (NC) beam and the (B2. B3. B4) strengthen and without strengthen.

8. CONCLUSIONS

The experimental tests results showed that Because (25,50,75) %respectively of the new aggregate was replaced with recycled aggregate, the load in the beam (NC) became approximately (4,9,14) % respectively higher than the (B2. B3. B4) beam. Due to the beams (B2. B3. B4) strengthen with the carbon sheet, the load in the beam (B2. B3. B4) strengthen is approximately (26,27,14) %respectively higher than in the beam (B2. B3. B4) without strengthen. Also, when reinforcing the beams (B2. B3. B4) using carbon fiber, the load in the

beam (B2, B3) reinforced with carbon fiber is higher by (0.17,0.16) %, respectively, than in the beam (NC). It was found in this study that it is possible to use recycled aggregates in concrete pouring at economic costs and to strengthen it with carbon sheet (CFRB). As previous studies did not look at strengthening concrete that contains recycled aggregates. One of the practical applications of beams is bridge that is made of beams with simple supports

9. RECOMMENDATIONS

Two recommendations can be reported here which are:

- 1- A study searching for the effect of shear on beams.
- 2- A study searching for the effect of torsion on beams.

10. REFERENCES

Standard, 2006, from (C&D) Malaysia Waste Corporation, Demolished Concrete & Aggregate Material.

Nitivattananon and Borongan, 2007, Recycled aggregates taken from (C&D) waste are now available.

Hajer, 2013, The Behaviour of Reinforced Green Concrete Piers of Bridge Using Different Types of Reinforcement Submitted to the Civil Engineering Department /College of Engineering Kerbala University.

J Xiao - Recycled aggregate concrete structures, 2018 - Springer.

W Cao- Time-Dependent Behavior of Full-Scale Recycled Aggregate Concrete Beams under Long-Term Loading 2020 Oct 29;13(21):4862.

HA Bengar, AA Shahmansouri -2020 Journal of Building Engineering, 2020 new anchorage system for CFRP strips in externally strengthened RC continuous beams.

J Zhang, P Zhou, C Guan, TQ Liu, WH Kang, P Feng... - Composite, 2021 An ultra-lightweight CFRP beam-string structure.