

Membrane Action in Orthotropically R.C. Rectangular Slabs Supported on Three Edges Only with Variable Axial Restraints

Dr. Hisham M. Al-Hassani* & Sura Abdul Muneim Salman*

Received on: 12/10/2009

Accepted on: 3/6/2010

Abstract

In this paper, large deformation analysis is carried out on uniformly loaded orthotropically reinforced concrete rectangular slabs that have one free edge and different restraints on the other edges. For the purpose of such analysis, the slabs are assumed to behave in a rigid-perfectly plastic manner and to yield under the combined effect of bending and membrane action. Two cases are analysed; the case of a slab having two adjacent edges fixed- one edge simply supported and one edge free, and the case of a slab having two adjacent edges simply supported- one edge fixed and one edge free.

Results of the analysis indicate considerable enhancements in the load carrying capacity of such slabs above those predicted by Johanson's simple yield line theory⁽¹⁾. The amount of the load enhancement in a particular slab is found to depend on many parameters such as the steel ratio ρ_x^+ , orthotropy ratio γ , compressive strength of concrete $f'c$, yield stress of steel f_y , and the slab aspect ratio L_y/L_x , such that a higher enhancement in load is achieved for a slab having a higher value of $f'c$ but lower values of L_y/L_x , ρ_x^+ , γ and f_y .

«الفعل الغشائي في البلاطات الخرسانة المسلحة مستطيلة الشكل ذات التسليح المختلف في الاتجاهين المتعامدين والمسندة من ثلاث حافات فقط بطبيعة اسناد مختلفة»

الخلاصة

في هذا البحث، أُجري تحليل التشوه الكبير لبلاطات خرسانية مستطيلة الشكل ذات حافة حرة واحدة وثلاث حافات مختلفة التقييد و مسلحة تسليحاً مختلفاً بالاتجاهين و محملة حملاً منتظماً. ولأغراض هذا التحليل، تم اعتبار أن هذه البلاطات ذات سلوكية جاسئة – لدنة و انها تخضع تحت التأثير المشترك للانحناء و الفعل الغشائي. تم تحليل حالتين، حالة البلاطة المقيدة من حافتين متجاورتين مع حافة واحدة بسيطة المساند وحافة واحدة حرة، وحالة البلاطة المسندة اسناداً بسيطاً عند حافتين متجاورتين مع حافة واحدة مقيدة وحافة واحدة حرة. أشارت نتائج التحليل الى وجود زيادات واضحة في سعة تحمل هذه البلاطات تفوق التخمينات النظرية لخط الخضوع المبسطة ليوهانسن (1)، وأن هذه الزيادة في الحمولة تتأثر بمتغيرات عديدة مثل نسبة حديد التسليح ρ_x^+ ومعامل اختلاف التسليح γ ومقاومة انضغاط الخرسانة $f'c$ واجهاد الخضوع للحديد f_y و النسبة الباعية للبلاطة L_y/L_x ، حيث تزداد نسبة الحمولة بزيادة $f'c$ ونقصان L_y/L_x و ρ_x^+ و γ و f_y .

1-Introduction:

Previous theoretical^(2,3,4,5) and experimental studies^(2,6,7,8,18,19) on RC slabs showed that the presence of restraining conditions at the edges of a slab can considerably enhance the load carrying capacity of the slab beyond that suggested by the simple Johansen's yield line theory⁽¹⁾ due to development of membrane action in the slab. Even in cases of unrestrained slabs, the self balanced in-plane membrane forces which develop inside the slab as a result of the applied loading have been found^(9,10) to help in producing higher yield loads with continuing deflection.

Six different cases can possibly be encountered in rectangular slabs having one free edge and different restraining conditions at the other edges as shown in Fig.(1), where the free edge in each case can either be a short or a long edge. The phenomenon of membrane action in these six slab cases have already been studied by some authors (as listed in table 1), but such studies were restricted to considering the slab to be either isotropic or orthotropic, rigid-plastic or elastic-plastic. Moreover, the method followed in determining the bending moment coefficients in the slab was either the finite element method (F.E.M) or the finite difference method (F.D.M).

In the present research, uniformly loaded RC rectangular slabs of cases (5) and (6) are analyzed under the combined effect of bending and membrane action to establish their load –deflection relationship. The slabs are assumed to be rigid-plastic, orthotropically reinforced and F.E.M is used to determine the bending moment coefficients in the slab.

Results of the analysis are compared with those obtained by, Sahagian⁽¹⁶⁾ (who considered the slabs to be isotropic, rigid-plastic) and with those found by Ahmed⁽¹³⁾ (who considered the slabs to be orthotropic, rigid-plastic but used F.D.M for the evaluation of the bending moment coefficients in the slab).

2.Evaluation of Bending Moments In Slab Cases 5 and 6 :

Fig.(2) shows that the slabs of cases 5 and 6 have one free edge running in X-direction of length L_x . In slab case5, the three supporting edges consist of two adjacent edges fixed while the third edge of length L_y is simply supported. In slab case 6 the conditions of the supporting edges are reversed where two adjacent edges are considered to be simply supported while the third edge of length L_y is fixed.

It is also shown in Fig. (2) that the positive bending moments in the two orthogonal directions at the middle of both slabs are designated as M_{ox}^+ and M_{oy}^+ while the negative bending moment at the middle of the fixed edge of length L_y in both slabs is M_{ox}^- and that at the middle of the fixed edge of length L_x in slab case (5) is M_{oy}^- .

All of these bending moments are related in Fig. (3) to the positive bending moment in X-direction M_{ox}^+ by using bending moment coefficients; namely γ , f_1 and f_2 , where γ is the ratio of the positive bending moments in Y to X direction (often known as the coefficient of orthotropy), f_1 is the ratio of negative to positive bending moments in the X-

direction, and f_2 is the ratio of negative bending moment in the Y-direction to the positive bending moment in X- direction;

$$\gamma = \frac{M_{oy}^+}{M_{ox}^+} \dots\dots\dots (1)$$

$$f_1 = \frac{M_{ox}^-}{M_{ox}^+} \dots\dots\dots (2)$$

$$f_2 = \frac{M_{oy}^-}{M_{ox}^+} \dots\dots\dots (3)$$

Non linear inelastic finite element analysis is carried out to find the bending moment coefficient γ , f_1 and f_2 for each ratio L_y/L_x of slab cases 5 & 6. The finite element mesh consists of 16 isoperimetric element to cover the whole slab^(21,22,23). The results of such analysis are listed in Table (2) and are shown plotted graphically in Fig. (4).

3. Analysis of Slab Cases 5 and 6 By the Simple Johansen's Yield Line Theory (Ignoring Membrane Action):

Figure (5) shows that there are two possible collapse modes for the slab of case 5 caused by the application of uniform load on the slab full area. The principle of virtual work is used to analyse these two failure modes and it is found that collapse mode I governs for all values of the slab aspect ratio L_y/L_x ranging between 0.5 and 2.

If the intensity of the collapse uniform load is denoted by w_j , the principle of virtual work applied to collapse mode "I" gives ;

$$W_j = \frac{6M_{ox}^+}{L_y^2} \left(\frac{(\gamma+f_2)}{Y_o} + \left(\frac{L_y}{L_x}\right)^2 \left\{ \frac{(1+f_1)}{X_o} + \frac{1}{(1-X_o)} \right\} \right) \dots\dots (4)$$

Setting $\frac{\partial w_j}{\partial X_o} = 0$ and $\frac{\partial w_j}{\partial Y_o} = 0$

give the true values of X_o and Y_o that fix the actual yield line pattern;

$$X_o = \frac{C_1 - 1}{C_1} \dots\dots(5)$$

$$Y_o = C_3 \left(\sqrt{1 + \frac{3}{C_3}} - 1 \right) \dots\dots(6)$$

where

$$C_1 = 1 + \sqrt{1 + f_1} ,$$

$$C_2 = (\gamma + f_2) , \quad C_3 = \frac{C_2}{C_1^2 (L_y/L_x)^2}$$

and the values of γ , f_1 and f_2 for any slab aspect ratio L_y/L_x are as given in Table (2).

A substitute of the values of X_o and Y_o obtained from Eq. (5) and (6) into Eq.(4) gives Johansen's collapse uniform load w_j for any particular aspect ratio L_y/L_x of slab case 5.

It is worth noting here that substituting $f_2=0$ in Eqs.(4),(5)and (6) gives directly the required solution for slab case 6 with the only difference is that the values of γ and f_1 must be taken as those belonging to slab case 6 in table (2).

Fig.(6) shows the variation of Johansen's collapse uniform load (estimated in non- dimensional form $w_j L_y^2 / M_{ox}^+$) with the slab aspect ratio L_y/L_x for the two cases 5 and 6 of the slabs under study .

4. Analysis of Slab Cases 5 and 6 by the Modified Yield Line Theory (Including Membrane Action):

Such analysis has been carried out and submitted as a M.Sc. thesis⁽¹⁷⁾

recently. The analysis in summary included the determination of the position of the neutral axis along the yield lines by combination of geometrical considerations and in-plane equilibrium. Firstly, the horizontal translation of the slab middle surface elements due to a vertical deflection Δ at the intersecting point of the sagging yield lines of the slab was obtained in terms of the axial strain at that point. A compatibility equation and plastic potential theory were then used to express the height of the neutral axis at any section along the yield lines in terms of the neutral axis depth at the section where the sagging yield lines intersect. Thereafter, the neutral axis depths at all sections were obtained by considering the horizontal force equilibrium of each of the three slab segments. A yield criterion of a slab section under the combined action of bending moment and axial compressive force was first derived and then used to evaluate the yield moments and membrane forces along the yield lines. Finally, the yield loads corresponding to any give central deflection Δ were found by considering the moment equilibrium equations for the three rigid elements of the slab⁽²⁴⁾.

According to such analysis, the obtained relationships between the non-dimensional yield load w/w_J with the slab relative central deflection Δ/h were found to be influenced by the following important parameters

1. Coefficient of orthotropy (γ)
2. Percentage of reinforcement (ρ_x^+)

3. Slab aspect ratio ($\frac{L_y}{L_x}$)
4. Slab material parameter $t \left(= \rho_x^+ \frac{f_y}{f_c'} \right)$

To study the effect of each parameter, a RC rectangular slab (of case 5 or 6 as appropriate) is considered with the following properties;

$$h/d = 1.2, \quad L_y/L_x = 0.5,$$

$$\rho_x^+ = 0.2\% \quad , \quad f_y = 400 \text{ MPa},$$

$$f_c' = 25 \text{ MPa}$$

Figures (7) and (8) show the effects of the afore mentioned important parameters on the load-deflection behavior of slab cases 5 and 6 respectively. It can be seen from these figures that according to the rigid-plastic idealization, the load is maximum at the start of collapse (i.e. at zero deflection) and is many times greater than the simple yield line theory load. With increasing deflection, the load is found to fall off rapidly until the stage is reached when the induced membrane forces in the central region of the slab become tensile enabling the slab to carry extra load by catenary action with further increments in deflection. The figures also clearly show that a higher load ratio W/W_J is obtained for lower values of γ , ρ_x^+ and L_y/L_x . Also that when the slab material parameter $t (= \rho_x^+ f_y / f_c')$ is decreased (i.e. decreasing both ρ_x^+ and f_y and increasing f_c') the load ratio w/w_J will be increased significantly.

5. Comparison of Results with Previous Studies:

The membrane action analysis of the present research, as listed in Table (1), is concerned with slab cases 5 and 6 considering these slabs to be orthotropic, rigid-plastic and with bending moment coefficients (γ, f_1, f_2) obtained using the finite element method (F.E.M). These two slab cases have also been analyzed by Sahagian⁽¹⁶⁾ [who assumed the slabs to be isotropic, rigid-plastic] and by Ahmed⁽¹³⁾ [who assumed the slabs to be orthotropic, rigid-plastic (or elastic-plastic), and with the bending moment coefficients (γ, f_1, f_2) obtained using the finite difference method (F.D.M)].

Comparisons between the results of the present analysis and those obtained by Sahagian⁽¹⁶⁾ and Ahmed⁽¹³⁾ for the two slab cases 5 and 6 are shown in Figs.(9) and (10) respectively. These two figures are constructed considering a typical slab of the following properties;

$$h/d = 1.2, \quad L_y/L_x = 2, \\ \rho_x^+ = 0.2\% \quad , \quad f_y = 400 \text{ MPa}, \\ f_c' = 25 \text{ MPa}$$

It can be seen from these two figures that Sahagian's isotropic slab showed higher effect of membrane action than do those orthotropic slabs of Ahmed and the present research, with the latter being the lowest effect. Nevertheless, all methods predict similar load-deflection behavior characterized by a high initial yield load ratio w/w_j which declines with increasing slab deflection and then showing some recovery in strength due to the presence of tensile membrane action in the central region

of the slab at higher values of deflection

6. Conclusions:

The following conclusions may be drawn from the results of the present investigation;

1. The analysis shows that RC rectangular slabs having one free edge and different restraining conditions at the other edges can sustain loads more than those predicted by Johansen's simple yield line theory.
2. The theoretical prediction of the load-deflection relationship (based on rigid-plastic idealization) shows that at zero deflection the load is maximum and many times greater than the simple yield line theory load. With increasing deflection, the load is found to fall off rapidly until the stage is reached when the induced membrane forces in the central region of the slab become tensile enabling the slab to carry extra load by catenary action with further increments in deflection.
3. The analysis has shown that the yield load depends on the slab relative deflection (Δ/h) and some other important parameters such as; percentage of steel reinforcement (ρ_x^+), yield stress of steel (f_y), compressive strength of concrete (f_c'), the slab rectangularity ratio (L_y/L_x) and coefficient of orthotropy (γ). The first three parameters have been found to play a significant role in changing the amount of enhancement in (w/w_j), where such enhancement is more pronounced in slabs with low values of (ρ_x^+), (f_y) and (γ) and

high values of (f_c'), whereas the parameter (L_y/L_x) has also been found to affect the amount of load enhancement such that for lower values of (L_y/L_x) the enhancement is greater.

4. For the two slab cases investigated in this research (i.e. slab cases 5 and 6) the enhancement in the yield load above Johansen's yield line theory load is found to be greater for isotropically R.C. slabs than that for orthotropically R.C. slabs.

References

- [1]. Johansen, K.W., "Yield Line Theory". Cement and Concrete Association, London, 1962. pp. 181.
- [2]. Al-Hassani, H.M., "Behaviour of Axially Restrained Concrete Slabs". Ph.D. Thesis, University College, London, England, 1978. pp. 241.
- [3]. Braestrup, M.W. and Morley, C.T., "Dome Effect in R.C. Slabs Elastic-Plastic Analysis". ASCE, Structural Engineering, Vol. 106, No. ST6, June 1980. pp. 1255-1262.
- [4]. Al-Hassani, H.M., "Ultimate Strength of Clamped Reinforced Concrete Rectangular Slabs under Combined Bending and Membrane Action". Journal of Engineering and Technology, Baghdad, Vol. 12, No. 4, 1993. pp. 71-103.
- [5]. Barzegar, F., "Layering of R.C. Membrane and Plate Elements in Non-Linear Analysis". Journal of Structural Engineering Division, ASCE, Vol. 114, No. ST11, Nov. 1988. pp. 2474-2492.
- [6]. Desayi, P. and Kulkarni, A.B., "Load-Deflection Behaviour of Restrained R/C Slabs". ASCE, Vol. 103, No. ST2, February 1977. pp. 405-419.
- [7]. Ouyang, C. and Suaris, W., "Reinforced Concrete Rectangular Slabs with Edges Restraints". ASCE, Structural Engineering, Vol. 113, No. ST11, 1987. pp. 2146-2165.
- [8]. Vecchio, F.J. and Collins, M.P., "Investigating the Collapse of a Warehouse". Concrete International Design and Construction, Vol. 12, No. 3, 1990. pp. 72-78.
- [9]. Kemp, K.O., "Yield of a Square Reinforced Concrete Slab on Simple Supports Allowing for Membrane Forces". The Structural Engineer, London, England, Vol. 45, No. 7, July 1967. pp. 235-240.
- [10]. Sawczuk, A. and Winnicki, L., "Plastic Behaviour of Simply-Supported Reinforced Concrete Plates at Moderately Large Deflections". International Journal of Solids and Structures, Vol. 1, 1965. pp. 97-111.
- [11]. Al-Rawas, M. Z., "Effect of Membrane Action in Reinforced Concrete Rectangular Slabs Supported on Three Edges only". M.Sc. Thesis, University of Technology, Baghdad June 2003. pp. 145.
- [12]. Al-Ameri M. T. " Membrane Action In Orthotropically R. C. Rectangular Slabs Having One Free Edge And Three Similarly Supported Edges ", M.Sc. Thesis, University of Technology, Baghdad October 2007

- [13]. Ahmed, A. A., "Behaviour of Orthotropically R.C. Rectangular Slabs Having One Free Edge and Different Restraint on the Other Edges". Ph. D Thesis, University Of Technology, March 2008, pp.169.
- [14]. Al-Shimmery, N. S., "Membrane Action in R.C. Rectangular Slabs Having One Free Edge and Different Restraints on the Other Edges". M.Sc. Thesis, University of Technology, Baghdad June 2005.
- [15]. Farhan, GH. K., "Membrane Action In Orthotropically R.C. Rectangular Slabs Having One Free Edge And Different Restraints on The Other Edges", M.Sc. Thesis, University of Technology, Baghdad May 2007
- [16]. Sahagian, S. Z., "Membrane Action in R.C. Rectangular Slabs Supported on Three Edges Only with Variable Axial Restraints". M.Sc. Thesis, University of Technology, Baghdad May 2006.
- [17]. Salman, S. AM., "Membrane Action in Orthotropically R.C. Rectangular Slabs Supported on Three Edges Only with Variable Axial Restraints". M.Sc. Thesis, University of Technology, Baghdad April 2009
- [18]. Tong, P.Y., "Compressive Membrane Action in Slabs with Non-Rigid Lateral Restraint". Journal of the Faculty of Engineering, University of Singapore, Singapore, Vol. 1, Dec. 1973. pp. 15-24.
- [19]. Braestrup, M.W. and Morley, C.T., "Dome Effect in R.C. Slabs Elastic-Plastic Analysis". ASCE, Structural Engineering, Vol. 106, No. ST6, June 1980. pp. 1255-1262.
- [20]. Datta, T.K. and Ramesh, C.K., "Some Experimental Studies on a Reinforced Concrete Slab-Beam System". Magazine of Concrete Research, London, U.K., Vol.27, No. 91, June 1975. pp. 111-120.
- [21]. Pryor Jr., C.W. and Barker, R.M., "A Finite-Element Analysis Including Transverse Shear Effects for Applications to Laminated Plates". AIAA Journal, Vol. 9, No. 5, May 1971. pp. 912-917.
- [22]. Mawenya, A.S. and Davvies, J.D., "Finite Element Bending Analysis of Multilayer Plates". International Journal for Numerical Methods in Engineering, Vol. 8, 1974. pp. 215-225.
- [23]. Barzegar, F., "Layering of R.C. Membrane and Plate Elements in Non-Linear Analysis". Journal of Structural Engineering Division, ASCE, Vol. 114, No. ST11, Nov. 1988. pp. 2474-2492.
- [24]. Park, R. and Gamble, W.L., "Reinforced Concrete Slabs". Copyright 2000 by John Wiley & Sons, Inc, Second Edition. pp. 716.

Table (1) Available Solutions of Membrane Action in R.C Rectangular Slabs Having One Free Edge

Slab Case	Author	Properties of The Analyzed slab	Method followed in determining the B.M coefficients
	Al-Rawas ⁽¹¹⁾	isotropic, rigid plastic	—
	Al-Ameri ⁽¹²⁾	orthotropic, rigid plastic	F.E.M*
	Ahmed ⁽¹³⁾	orthotropic, rigid plastic or elastic - plastic	F.D.M**
	Al-Shimmery ⁽¹⁴⁾	isotropic, rigid plastic	—
	Farhan ⁽¹⁵⁾	orthotropic, rigid plastic	F.E.M*
	Ahmed ⁽¹³⁾	orthotropic, rigid plastic or elastic - plastic	F.D.M**
	Sahagian ⁽¹⁶⁾	isotropic, rigid plastic	—
	Present research ⁰	orthotropic, rigid plastic	F.E.M*
	Ahmed ⁽¹³⁾	orthotropic, rigid plastic or elastic - plastic	F.D.M**

* F.E.M.=Finite Element Method

** F.D.M=Finite Difference Method

Table (2) Variation of (γ , f_1 , f_2) with ratio (L_y/L_x) for slab cases (5) and (6)

L_y/L_x	Slab case 5			Slab case 6	
	γ	f_1	f_2	γ	f_1
0.5	0.5328	1.5181	0.5993	0.2992	1.2259
0.75	0.5755	1.2015	0.5899	0.3800	1.1048
1	0.5817	1.0886	0.6033	0.3703	1.0604
1.25	0.5199	1.0489	0.5365	0.3858	1.0241
1.5	0.4892	0.9966	0.5008	0.4107	0.9995
1.75	0.4583	0.9876	0.4673	0.4052	0.9818
2	0.4348	0.9843	0.4416	0.4086	0.9823

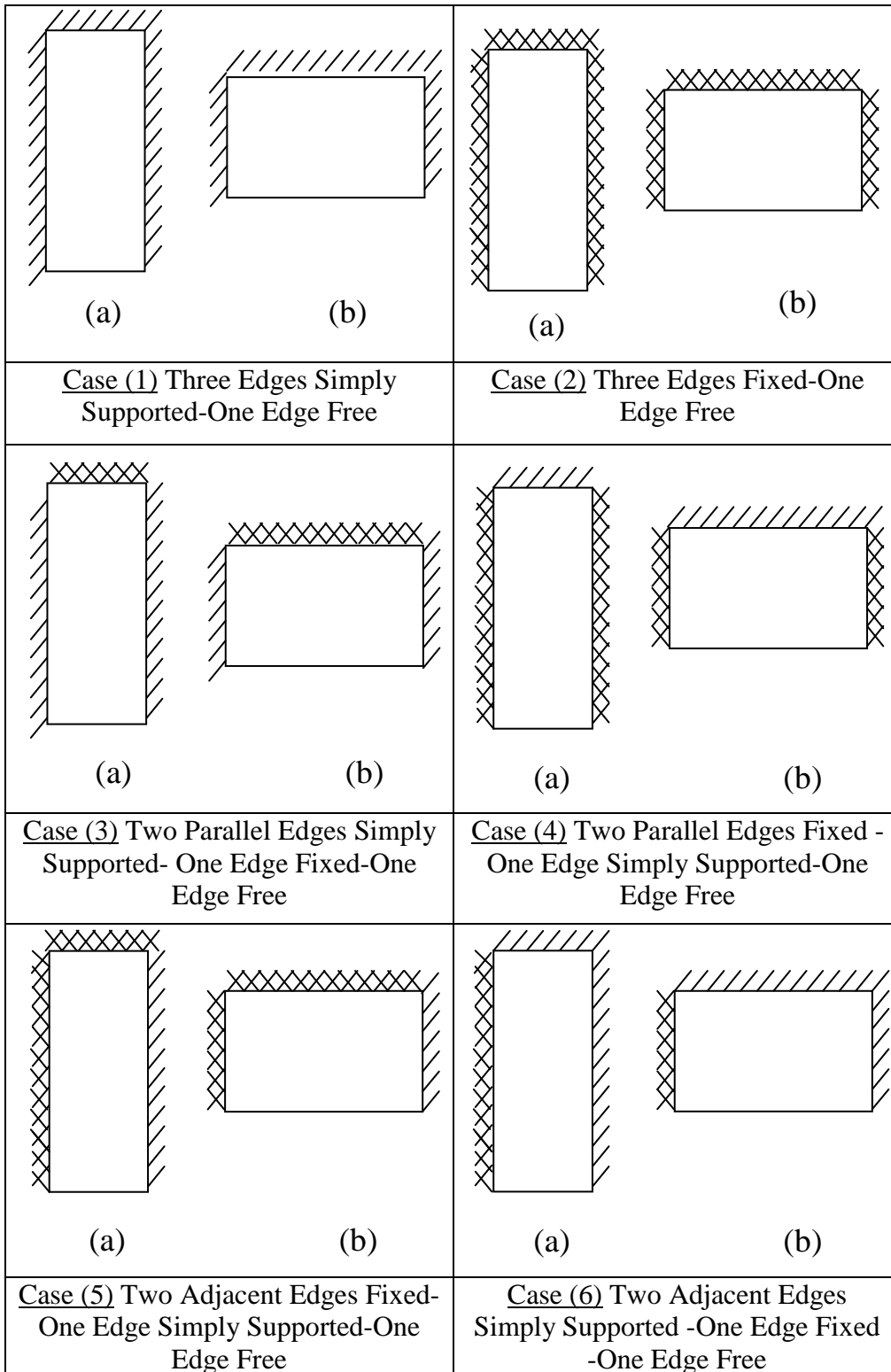
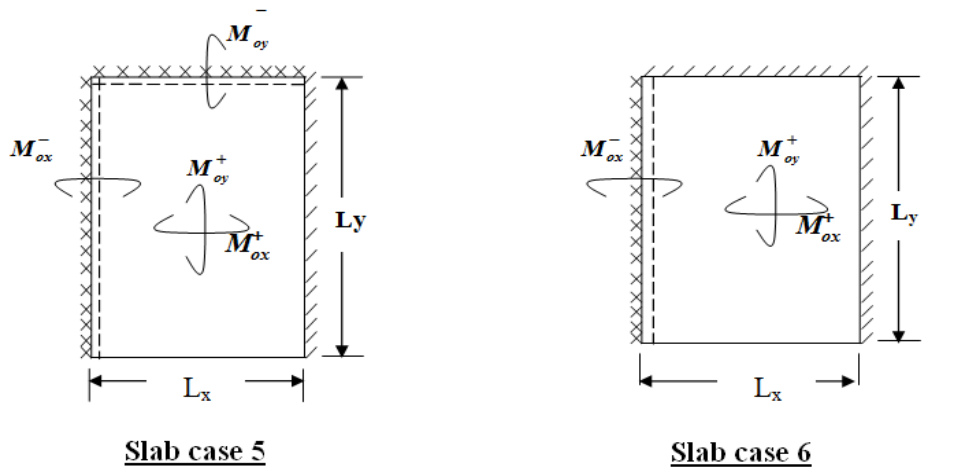

Figure (1) The Six Different Cases of R.C Rectangular Slabs Having One Free Edge



Figure(2) Distribution of bending moments in slab cases (5) and (6)

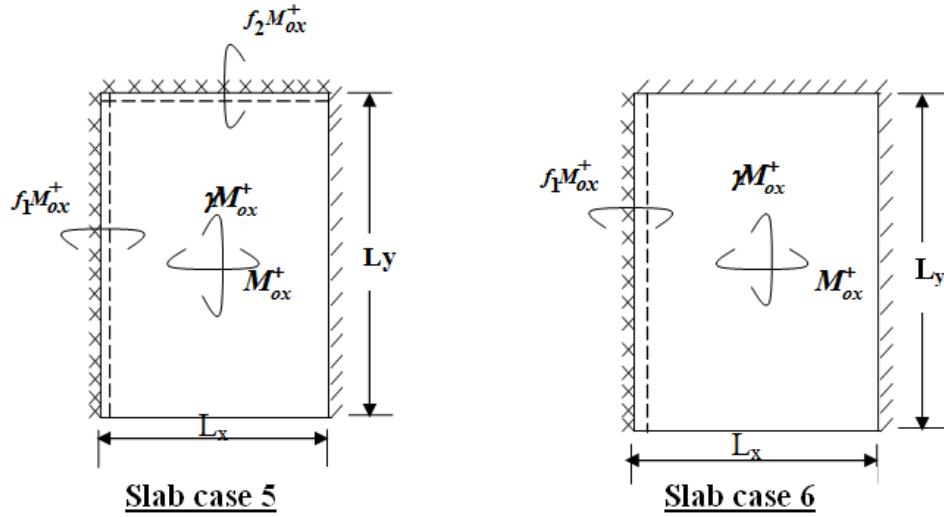

Figure (3) Relating all bending moment in slab cases (5) and (6) to M_{ox}^+

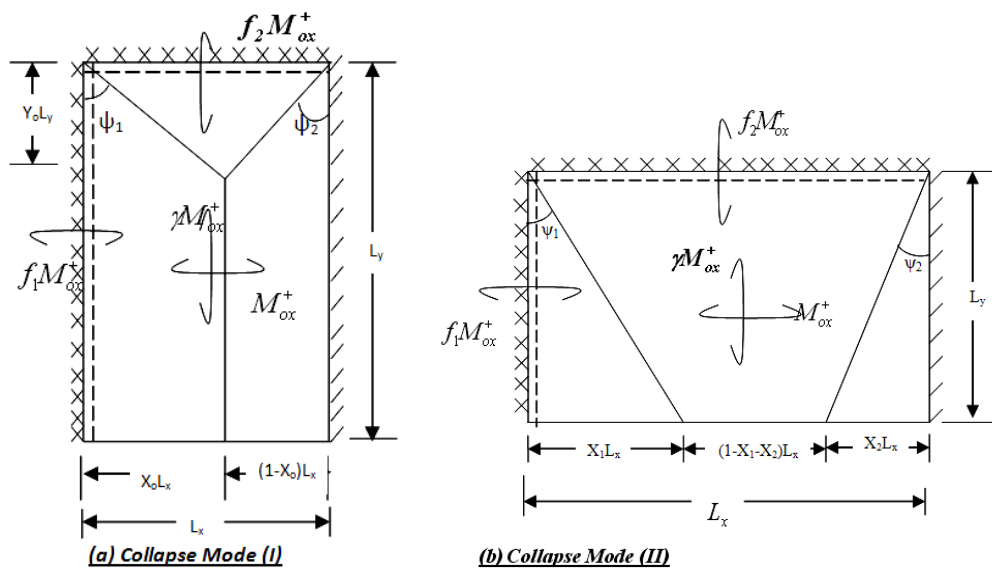

Figure (4) The Two Collapse Modes of Slab Case (5)

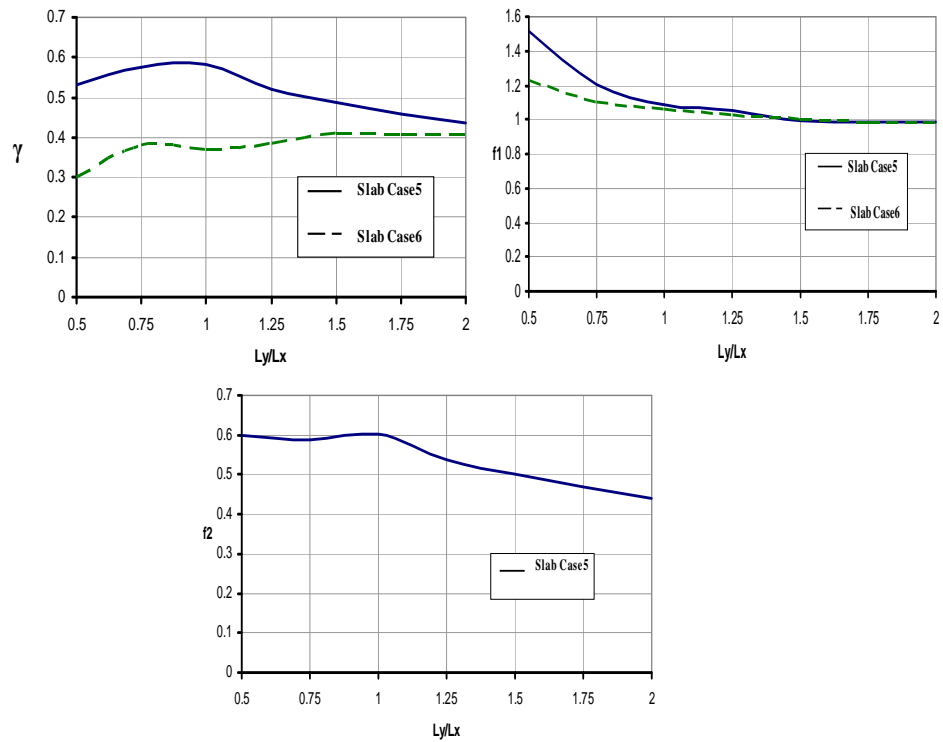

Figure (5) Plots showing variations of (γ, f_1, f_2) with ratio L_y/L_x for slab cases (5) and (6).

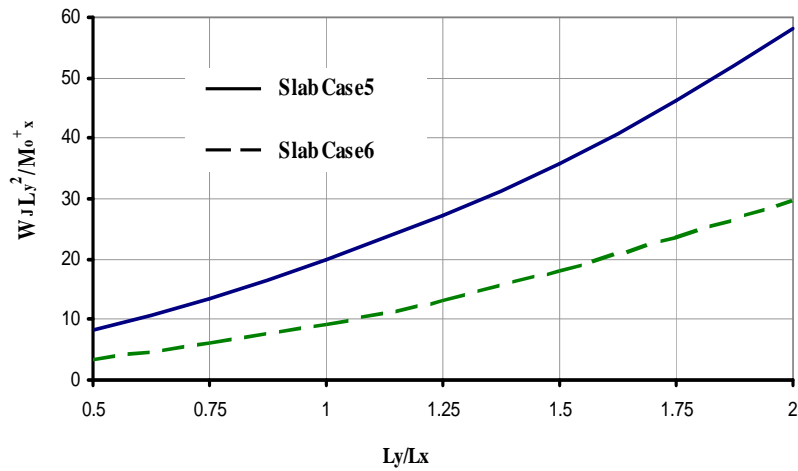

Figure (6) Estimation of The Collapse Uniform Load According to Johansen Theory for Slab Cases 5 and 6.

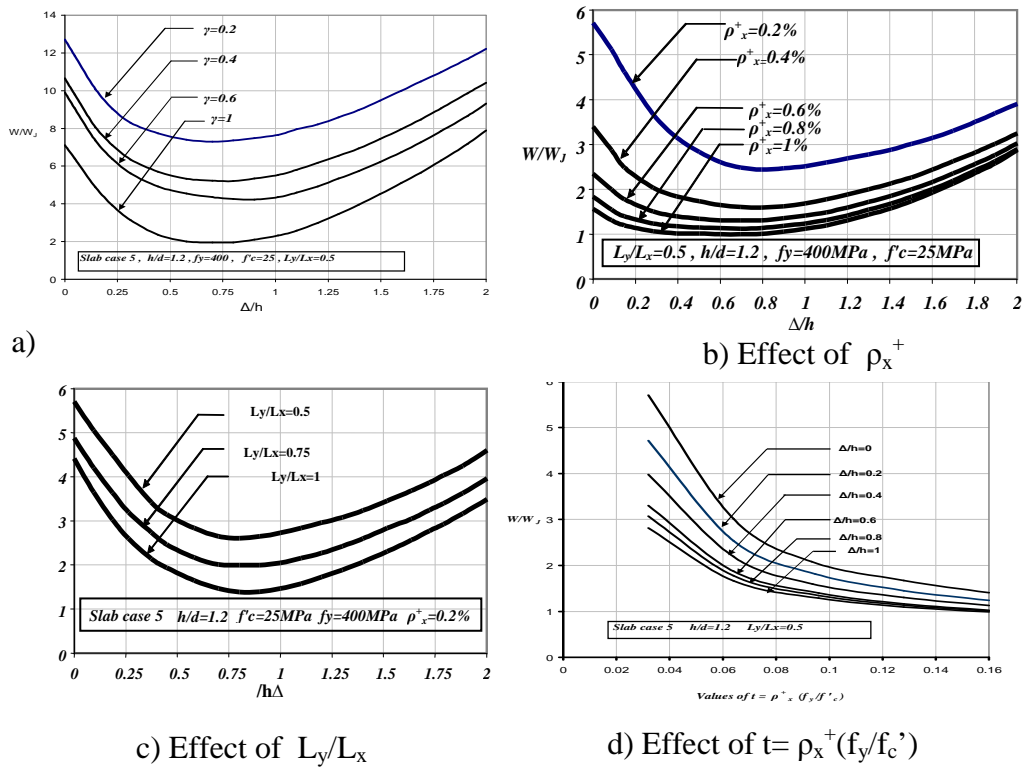

Figure (7) Effects of Some Important Parameters on the Load –Deflection Behavior of Slab Case 5

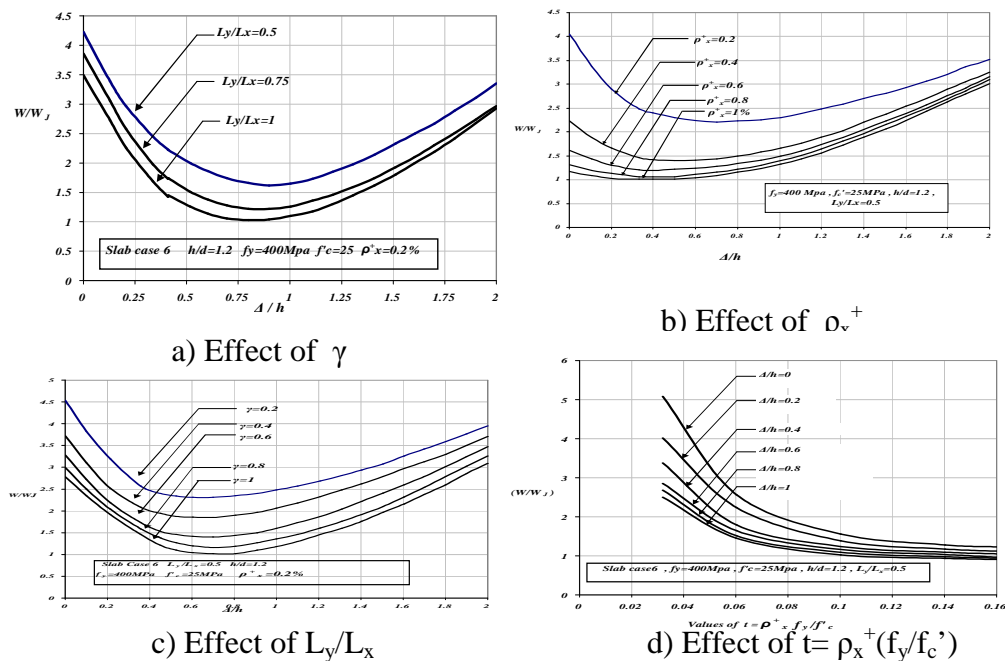

Figure (8) Effects of Some Important Parameters on the Load –Deflection Behavior of Slab Case 6

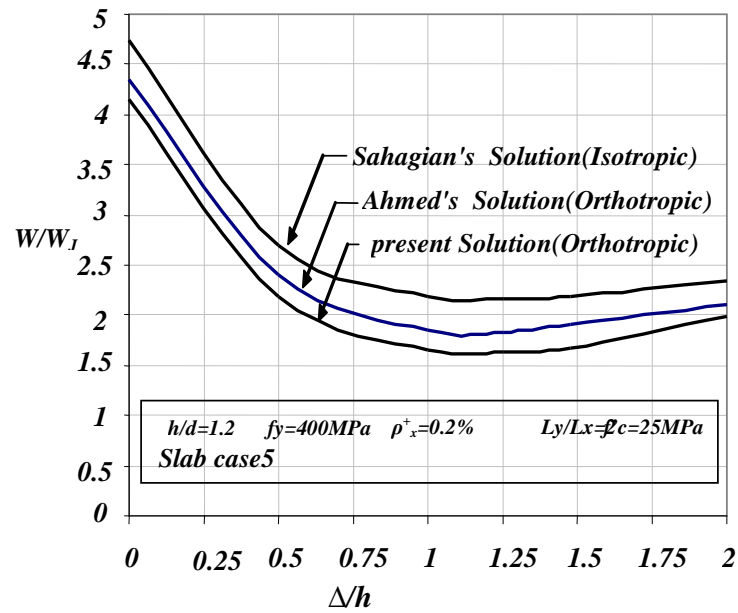

Figure (9) Comparison with Previous Solution-Slab Case 5

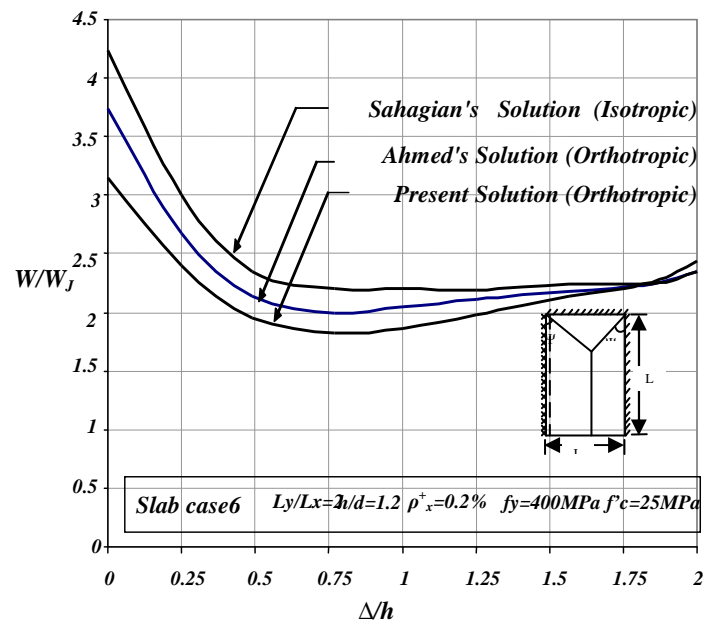

Figure (10) Comparison with Previous Solution-Slab Case 6