

## PSO Based PID Controller Design for a Precise Tracking of Two-Axis Piezoelectric Micro positioning Stage

**Dr. Hazem I. Ali**

Control and Systems Engineering Department, University of Technology/Baghdad  
Email: [hazemcontrol2001@yahoo.com](mailto:hazemcontrol2001@yahoo.com)

**Yasir Khudhair Abbas**

Control and Systems Engineering Department, University of Technology/ Baghdad

**Ali Majeed Mahmood**

Control and Systems Engineering Department, University of Technology/ Baghdad

Received on: 27/1/2013 & Accepted on: 4/7/2013

### ABSTRACT

In this paper the design of an optimal PID controller for single and double axis piezoelectric micropositioning stage system is presented. The Particle Swarm Optimization (PSO) method is used to tune the parameters of the PID controller subject to specific objective function. The proposed controller provides a high performance trajectory tracking responses of the piezoelectric micropositioner stage. A simulation results are presented to show the effectiveness of the proposed control algorithm.

تصميم مسيطر تناسبى-تكاملى-تفاضلى بالإعتماد على خوارزمية أمثلية الحشد الجزئى لغرض تتبع دقيق لنظام تموضع كهروإجهادى ذو محورين

### الخلاصة

في هذا البحث تم تصميم مسيطر تناسبى-تكاملى-تفاضلى للسيطرة على نظام تموضع كهروإجهادى لمرحلة ذات محور ومحورين. ولغرض تنعيم معاملات المسيطر التناسبى-التكاملى-التفاضلى فقد تم استخدام خوارزمية أمثلية الحشد الجزئى بالإعتماد على دالة هدف معينة. إن هذا النوع من المسيطرات يحقق استجابات لمسار التتبع بمواصفات أداء عالية لنظام التموضع الكهروإجهادى. ولأجل عرض قوة هذا المسيطر المقترح فقد تم استعراض نتائج المحاكاة للنظام المستخدم.

### INTRODUCTION

The piezoelectric actuators have become one of the most important devices that can be used in high precision positioning applications. They are used microscopy applications such as scanning tunneling microscopy, scanning near field optical microscopy and high frequency vibration control [1].

However, since the materials of piezo-actuators are ferroelectrics, they exhibit hysteresis behavior in response to an applied electric field. This behavior leads to severe inaccuracy and instabilities when these systems are operated in an open loop mode. Furthermore, the hysteresis characteristics of these systems are unknown and it is difficult to establish a dynamic model for systems with a hysteresis effect [2, 3, 4].

The paper is organized as follows: Section 2 provides an overview of the PSO algorithm. In section 3, the Piezoelectric Micropositioner is described. Section 4 presents a modeling of piezoelectric Micropositioner system. The controller design using PSO method is presented in section 5. Finally, the results that show the effectiveness of the designed controller are presented and discussed in section 6.

### PARTICLE SWARM OPTIMIZATION (PSO) ALGORITHM

PSO is one of a powerful optimization method with high efficiency in comparison to other methods. The PSO mechanism is initialized with a population of random solutions and searches for optima by updating generations. The potential solutions of PSO are called “particles”, fly through the problem space by following the current optimum particles. Each particle keeps track of its coordinates in the space of the problem, which are associated with the best solution (best fitness) it has achieved so far. The best particle in the population is denoted by (global best), while the best position that has been visited by the current particle is denoted by (local best). The global best individual connects all members of the population to one another. That is, each particle is influenced by every best performance of any member in the entire population. The local best individual is seen as the ability for particles to remember past personal success. The particle swarm optimization concept involves, at each time step, changing the velocity of each particle towards its global best and local best locations. The particles are manipulated according to the following equations of motion [5, 6]:

$$v_i^{k+1} = w \times v_i^k + c_1 \times rand \times (x_i^b - x_i^k) + c_2 \times rand \times (x_i^g - x_i^k) \quad \dots (1)$$

$$x_i^{k+1} = x_i^k + v_i^{k+1} \quad \dots (2)$$

Where  $v_i^k$  is the particle velocity,  $x_i^k$  is the current particle position,  $w$  is the inertia weight,  $x_i^b$  and  $x_i^g$  are the best value and the global best value,  $rand$  is a random function between 0 and 1,  $c_1$  and  $c_2$  are learning factors. The PSO requires only a few lines of computer code to realize PSO algorithm. Also it is a simple concept, easy to implement, and computationally efficient algorithm [7].

### PIEZOELECTRIC MICROPOSITIONER DESCRIPTION

The outline sketch of the two-Axis piezoelectric Micropositioner stage is shown in Figure (1). This stage is driven by stacked piezo-actuators used where this

Micropositioner works with displacement range of  $(0 - 80\mu m)$  for both  $x$  and  $y$  directions. The piezoelectric stage comprises of the following parts [8]:

1. Element Stacked piezo-actuator.
2. Heavy base.
3. Flexure mount.
4. Lever arm.
5. movable top plate.
6. Strain-gauge transducers.

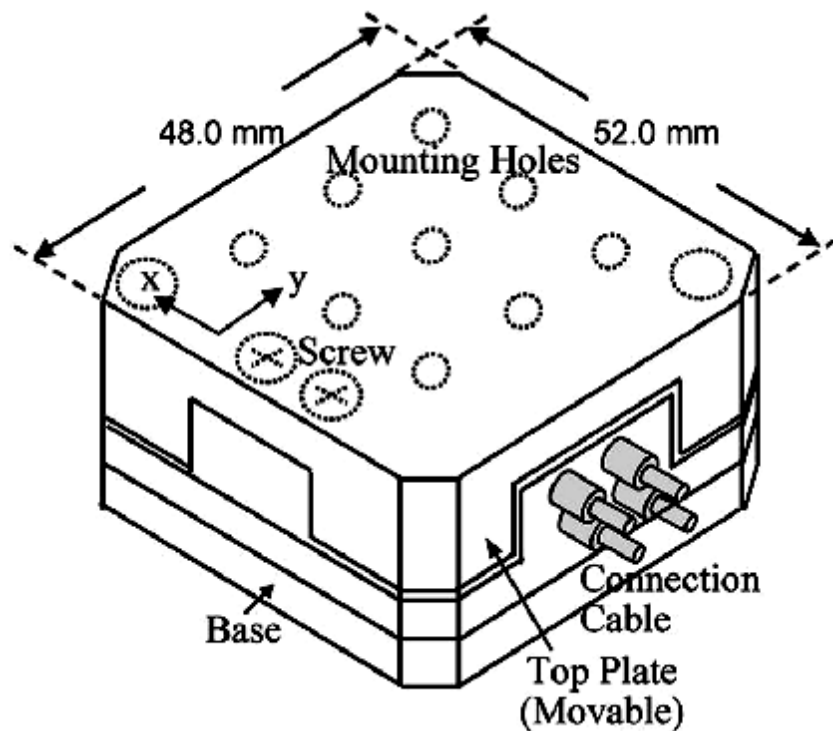

**Figure (1) Outline Sketch of Piezoelectric Micropositioner [8].**

Figure (2) shows the working principle for the piezoelectric stage about single-axis motion. The main body of the stage is fixed to a heavy base and the movable plate on the top of the stage is a platform for the components mounted to be scanned. The movement of the top plate is due to an internal lever-transmission of extension of the built-in stacked piezo-actuators with solid state flexure hinges. When an input voltage is applied to the stage, the extension of the stacked piezo-actuators occurs and then this extension causes the bending of the flexure mounts. This bending gives rise to a deviation of the top plate [4].

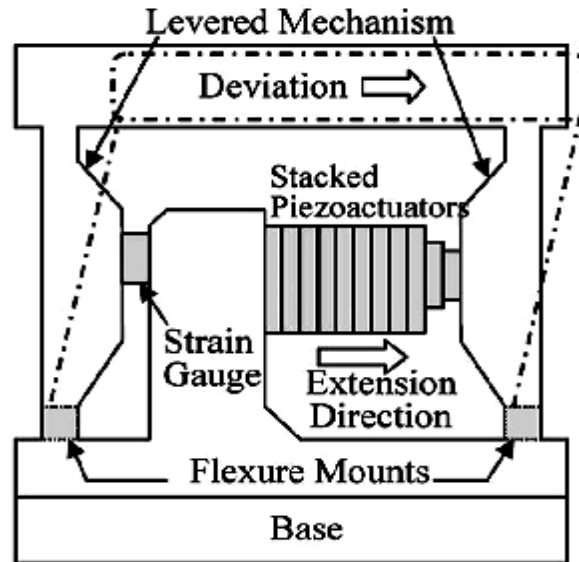

Figure (2) Working Principle of the Piezo-Positioning Stage [4].

The input voltage to the piezoelectric micropositioner is derived through a control system setup whose block diagram is shown in Figure (3), which contains a voltage amplifier, signal conditioner, and computer with data acquisition interface [8].

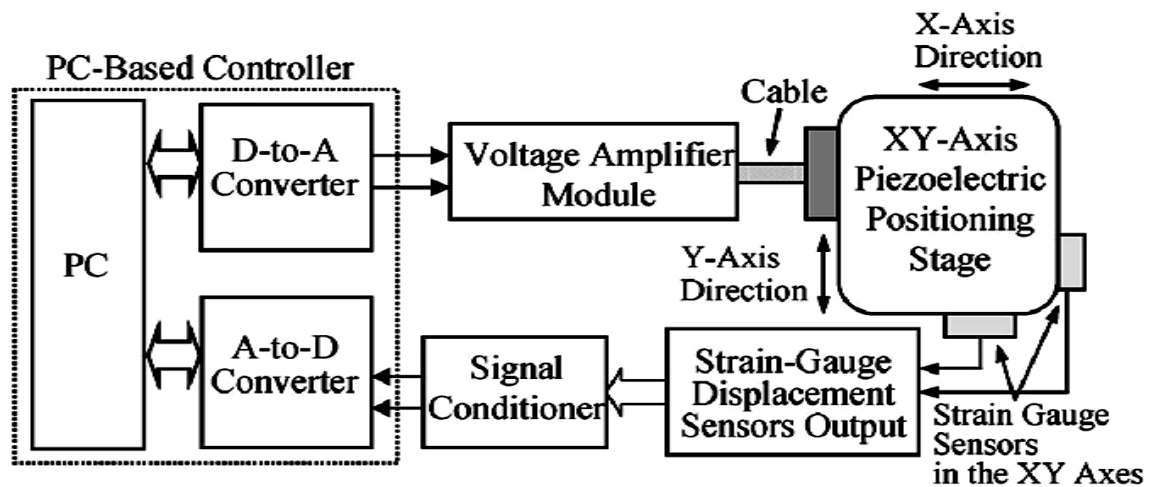

Figure (3) A Block Diagram for a Control System Setup of the Piezoelectric Micropositioner [8].

As shown in Figure 3, the equipped devices are briefly described in the following way [8]:

- i. Voltage amplifier was developed by high voltage – type Op-Amplifier with model PA240, manufactured by (APEX Microtechnology, USA) which have the specification of maximum peak-peak voltage 350V, maximum output current 250 mA, and bandwidth 3MHZ. Moreover, the linear amplification gain of 5 is set. The amplifier implementation for driving the piezoelectric micropositioner is shown in Figure 4, in which a phase lead-lag compensator is cascaded to obtain an improved stability in the sense of bode diagram.
- ii. Signal conditioner for strain gauge transducer was set up by chip with model 1B32, produced by (Analog Devices, Inc.). Which the output voltage range was set to (0 - 10) V for the ranged displacement of (0–80 μm ).
- iii. A computer for control algorithm implementation and a data acquisition board with analog to digital (A/D) and digital to analog (D/A) conversion were applied.

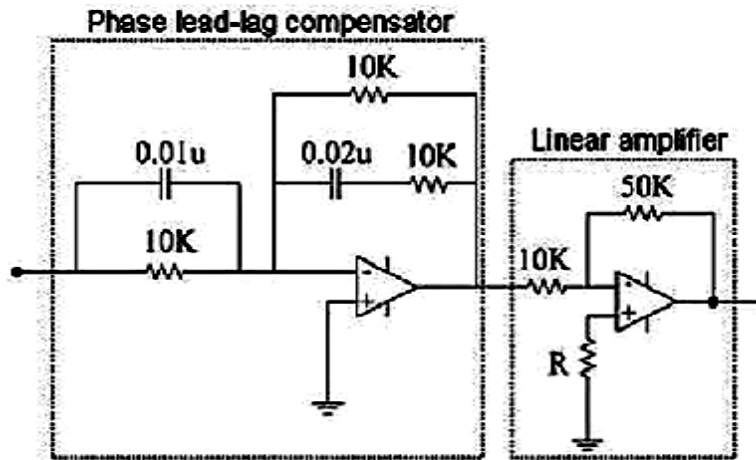

Figure (4) Diagram of the Drive Amplifier Circuit for the Piezoelectric Micropositioner [8].

### MODELING OF PIEZOELECTRIC MICROPOSITIONER SYSTEM

A second order linear differential equation is considered to represent the dynamic model of the piezoelectric micropositioner stage system. The state space model for both x and y axis of the piezoelectric micropositioner system is defined as [8]:

$$\begin{aligned}
 x_1 &= x, \\
 \dot{x}_2 &= \& \\
 x_3 &= y, \\
 \dot{x}_4 &= \&
 \end{aligned}
 \quad \dots (3)$$

Where:

$x_1$  : denotes the displacement in the x-axis displacement ( $m$ ),

$x_2$  : denotes its velocity in the x-axis displacement ( $m$ ),

$x_3$  : denotes the displacement in the y-axis displacement ( $m/sec$ ),

$x_4$  : denotes its velocity in the y-axis displacement ( $m/sec$ )

With the assumption of equation (3), the linear state space equations can be expressed by:

$$\begin{aligned} \dot{x} &= Ax + Bu \\ y &= Cx \end{aligned} \quad \dots (4)$$

Where:

$$A = \begin{bmatrix} 0 & 1 & 0 & 0 \\ a_{21} & a_{22} & 0 & 0 \\ 0 & 0 & 0 & 1 \\ 0 & 0 & a_{42} & a_{44} \end{bmatrix}, B = \begin{bmatrix} 0 \\ b_1 \\ 0 \\ b_2 \end{bmatrix}, C = \begin{bmatrix} 1 & 0 & 0 & 0 \\ 0 & 0 & 1 & 0 \end{bmatrix},$$

$x = [x_1 \quad x_2 \quad x_3 \quad x_4]^T$  : is the state vector.

$u = [u_x \quad u_y]$ : are the control action voltages in both  $x$  and  $y$  directions, respectively.

The model identification work is done in [8] by using a dynamic signal analyzer that is used to capture the magnitude response in frequency domain. Then, a curve-fitting tool in MATLAB computer software is adopted to find out an approximated second-order linear transfer function for each axis stage actuator, where the magnitude response in frequency domain is very close to the actual one captured by the dynamic signal analyzer. From the captured data of the magnitude response in frequency domain, the following model parameters are obtained as shown in Table (I).

**Table (I) Piezoelectric Micropositioner Identification Parameters.**

Parameter	Value
$a_{21}$	-30695.04
$a_{22}$	-350.48
$a_{42}$	-30695.04
$a_{44}$	-350.48
$b_1$	-30695.04
$b_2$	-30695.04

In this study both  $x$  and  $y$  stage piezoelectric actuators are assumed to be identical.

**CONTROLLER DESIGN**

The PID controller  $G_c(s)$  is cascaded with the specified process  $G_p(s)$  in order to provide a suitable loop transfer function  $L(s) = G_c(s)G_p(s)$ . The PID controller is expressed by [9]:

$$G_c(s) = K_p + \frac{K_i}{s} + K_d s \quad \dots (5)$$

Where  $K_p$ ,  $K_i$  and  $K_d$  are the controller parameters. To ensure optimal control performance at nominal operating conditions, The PSO method is used to tune the parameters of the PID controller. The block diagram of PID controller tuned by PSO method is shown in Figure (5). On the other hand, the performance criterion used to design the controller is the integral of time multiplied by absolute error (ITAE), which is expressed as [10]:

$$ITAE = \int_0^T t |e(t)| dt \quad \dots (6)$$

Where  $T$  is a finite time chosen somewhat arbitrarily so that the integral approaches a steady state value. The PSO flowchart for obtaining the optimal parameters of the controller is shown in Figure (6).

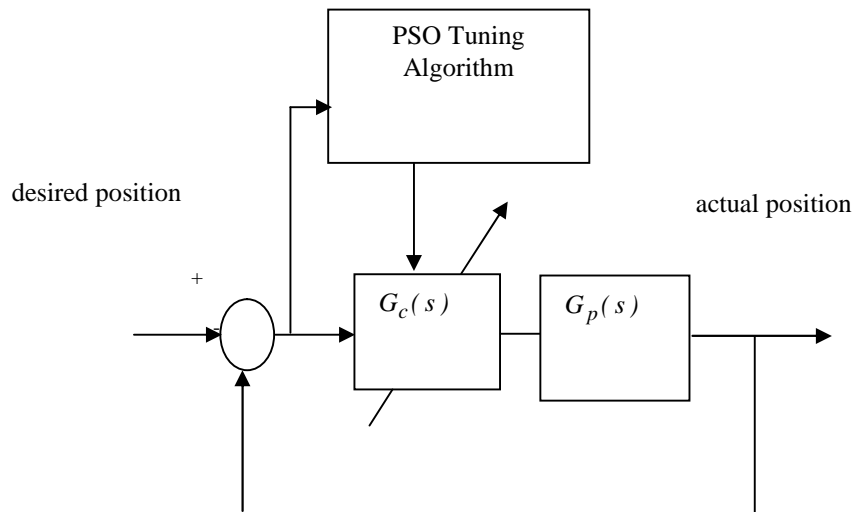

**Figure (5) the block diagram of PID controller tuned by PSO method.**

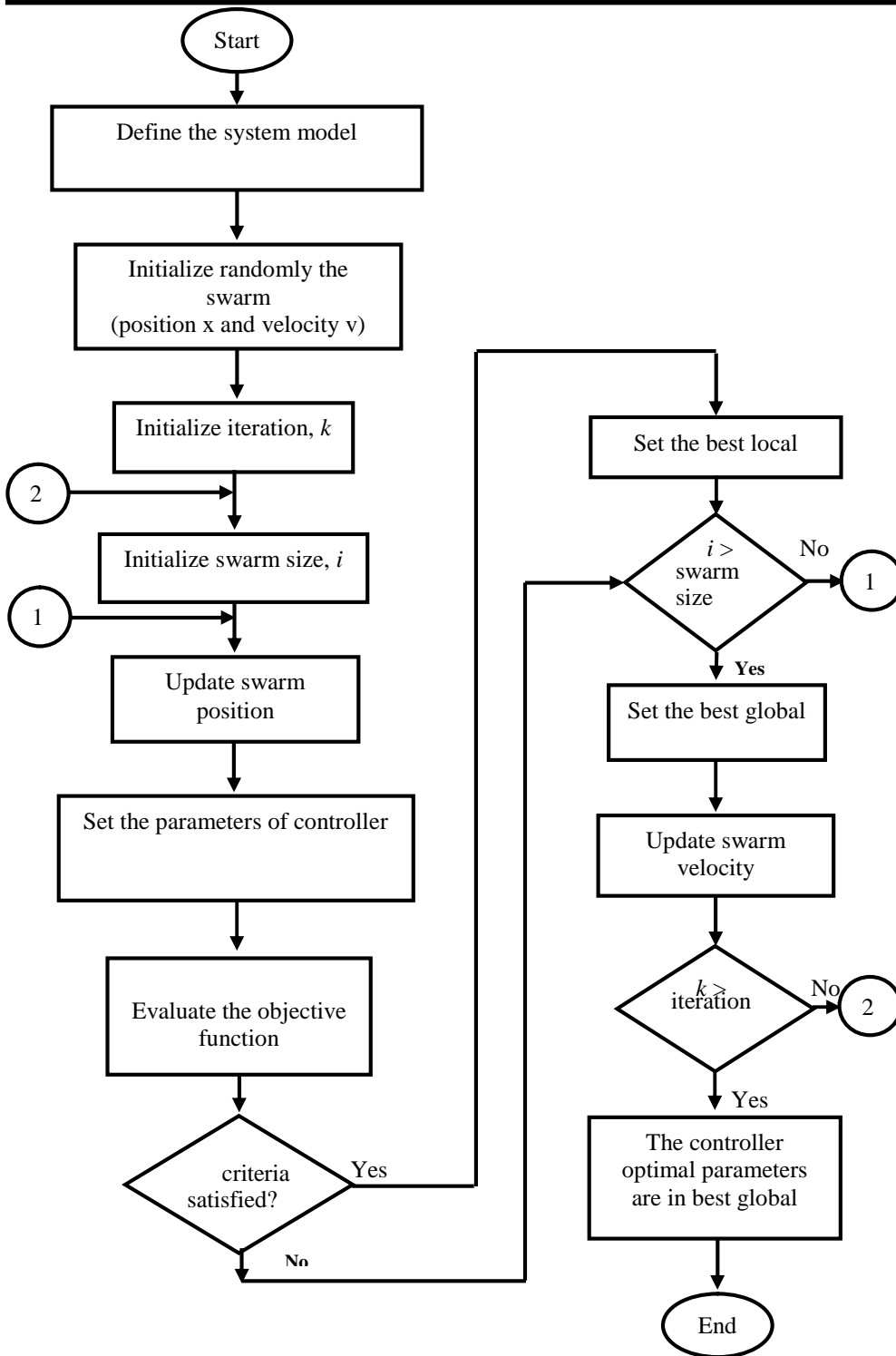

Figure (6) Flowchart of PSO algorithm.



The obtained optimal PID controller parameters using PSO method are  $K_p = 125.2568$ ,  $K_i = 0.0680$  and  $K_d = 0.0296$ .

## RESULTS AND DISCUSSION

The simulation results of applying the PSO based PID controller to the single and double axis piezoelectric micropositioning stage system have been obtained using Matlab 7.8 package. Three test signals were used to show the effectiveness of the proposed controller. Figure (7) shows the time response specifications of the single axis piezoelectric micropositioning system when a step input is applied. From this figure it is shown that a more desirable tracking performance has been achieved, where the system output can reach to the desired position in less than 0.012 seconds. On the other hand, from Figures 8 and 9 we can find that the proposed controller can achieve a precise tracking of the two axis micropositioning stage system when a sinusoidal and square function inputs are applied. Figure 10 shows the time response specifications of the double axis piezoelectric micropositioner stage. It is shown that an efficient tracking for both stages to the desired inputs has been achieved using the proposed controller. The circular-shaped trajectory can be shown in Figure (11). It is clear that the piezoelectric micropositioner stage system can track a circle trajectory with 1  $\mu m$  radius. Finally, to show the effectiveness of the proposed controller, a comparison between the performances of the proposed controller with the optimal PID controller using LQR in [8] is presented in Table (II).

## CONCLUSIONS

In this paper the design of PID controller is presented. To ensure the optimal control performance of the Two-Axis Piezoelectric Micropositioning system, the Particle Swarm Optimization (PSO) method is used to tune the parameters of PID controller. Precise tracking of the two axis piezoelectric micropositioning stage system has been presented.. The PSO method has been used to tune the PID controller parameters by minimizing the integral time absolute error. It was shown that, the designed controller could achieve a more desirable tracking performance in comparison with a previous work.

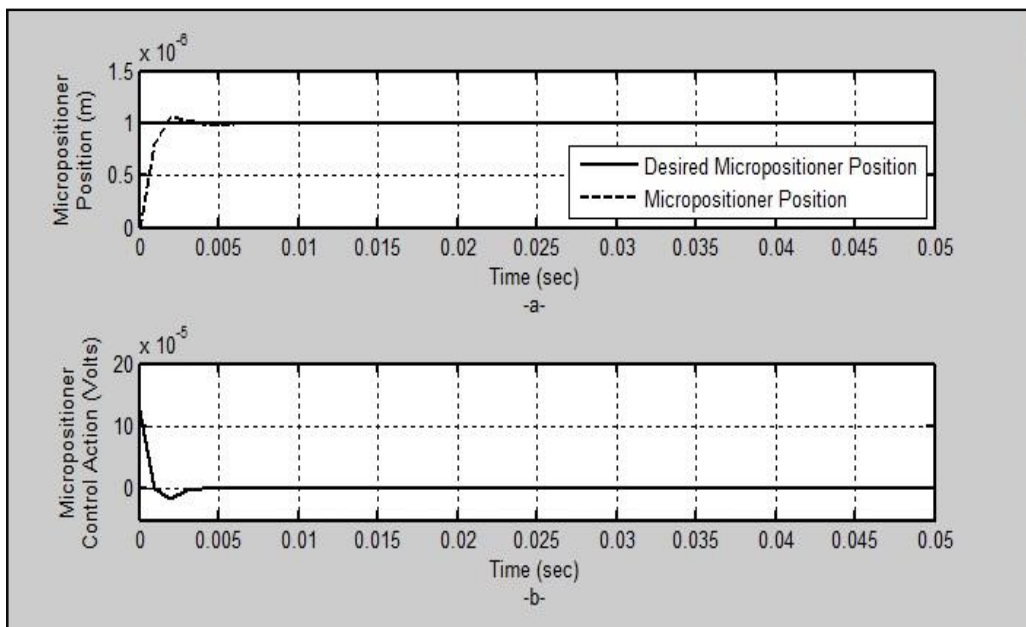

Figure (7) Simulation Results with step input =  $1 \mu m$   
 a- Time Response. b- Control Action.

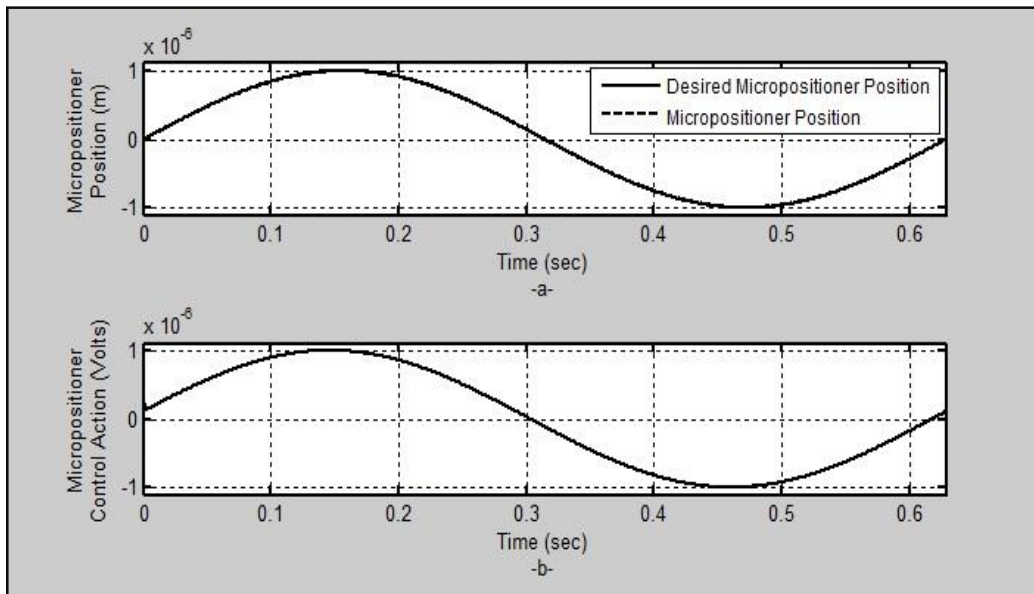

Figure (8) Simulation Results with sinusoidal input, magnitude=  $1 \mu m$ ,  
 frequency=10 rad/s a- Time Response. b- Control Action.

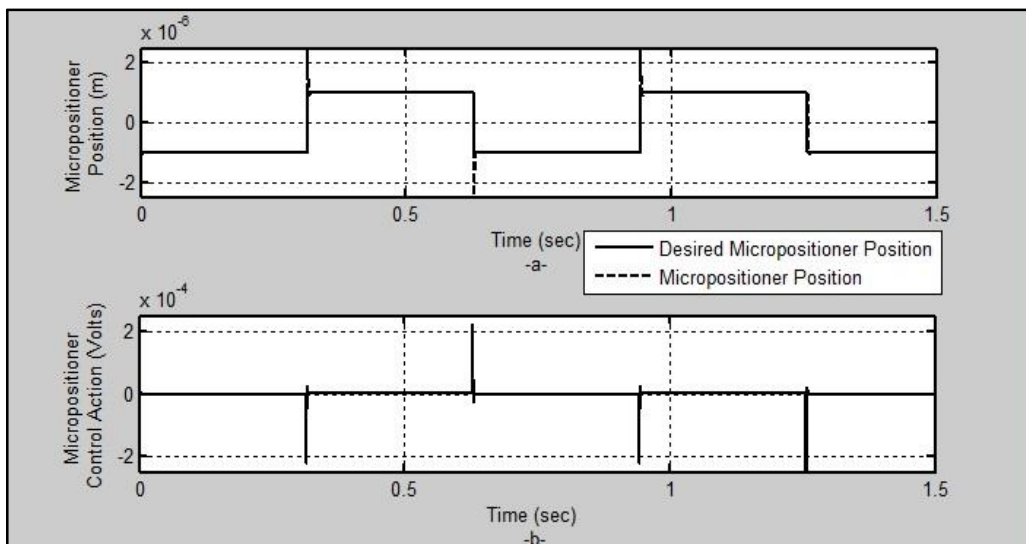

Figure (9) Simulation Results with square function input, magnitude= $1\mu m$ , frequency= $10\text{ rad/s}$  a- Time Response. b- Control Action.

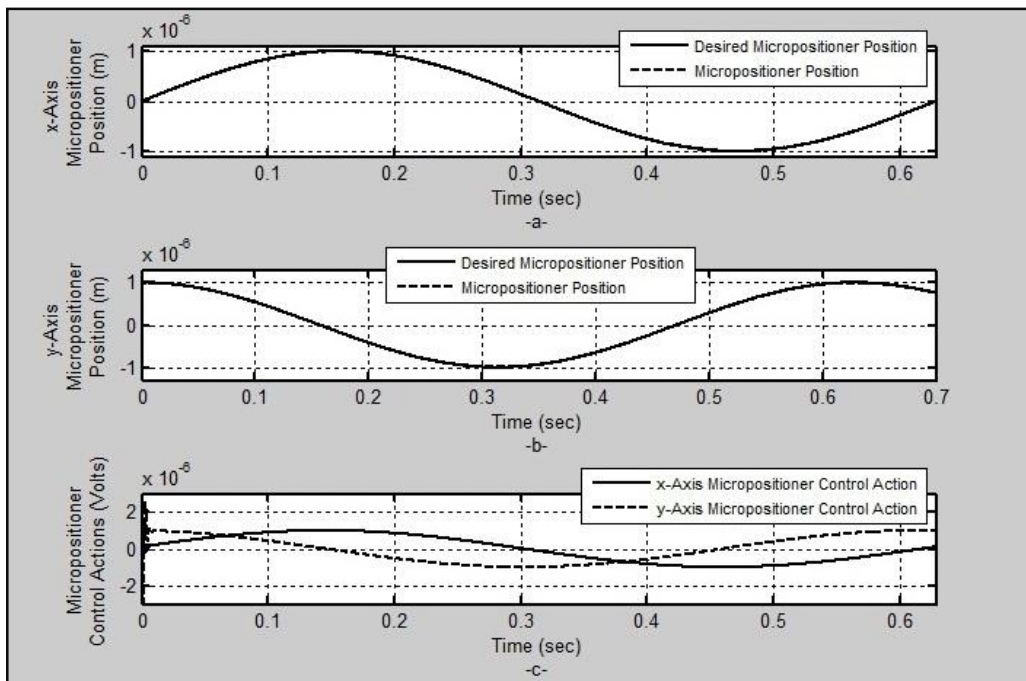

Figure (10) Simulation Results with Sinusoidal Ref. Inputs of Double-Axis Piezoelectric Micropositioner Stage Position. a- Time Response of x-Axis. b- Time Response of y-Axis. c- Double-Axis Control Actions.

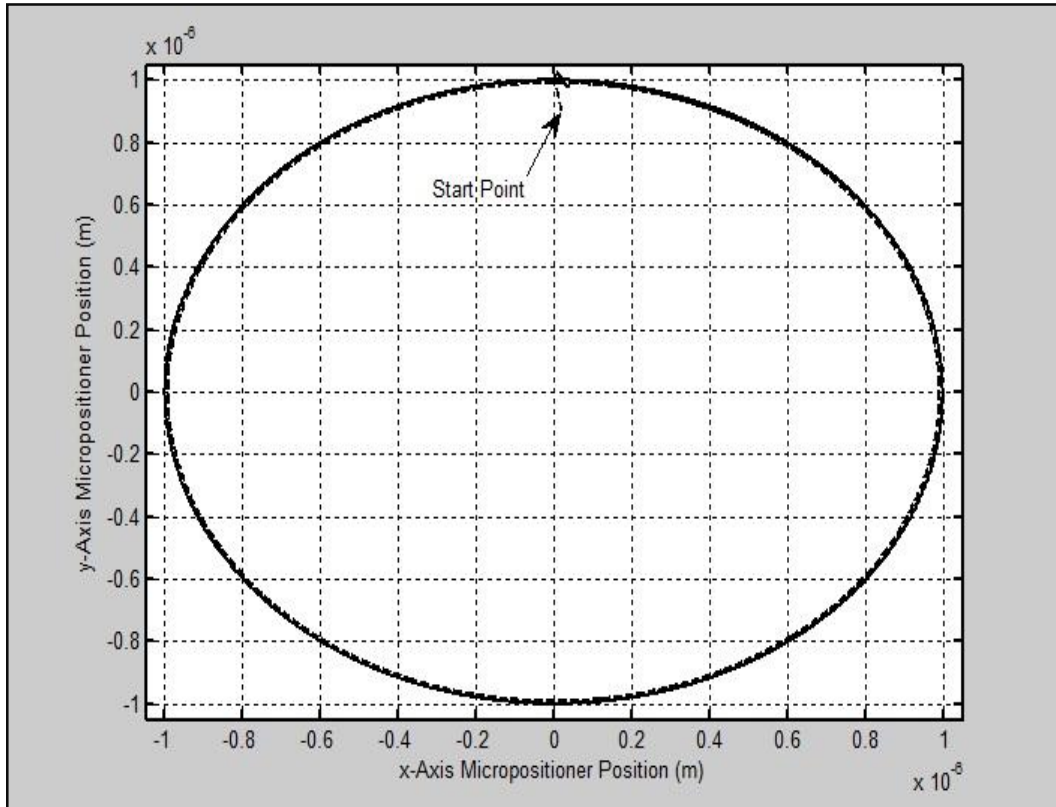

Figure (11) Simulation Results of Piezoelectric Micropositioner Stage Circle Trajectory.

Table (II) Time response specifications comparison.

Controller	Rise time, $t_r$ (s)	Peak overshoot, $M_p$	Settling time, $t_s$ (s)
Optimal PID controller using LQR [8]	0.02	-	0.05
Optimal PID controller using PSO (proposed)	0.00178	$0.3 \times 10^{-6}$	0.012

**REFERENCES**

- [1]. Shieh,H. J. F. J. Lin, P. K, Huang and L. T, Teng, “Adaptive tracking control solely using displacement feedback for a piezo-positioning mechanism”, IEE Proceedings-Control Theory and Applications, Vol. 151, No. 5, 2004, pp. 653-660.
- [2]. Choi, G. S. H. S. Kim and G. H. Choi, “A study on position control of piezoelectric actuators”, Proceedings of IEEE International Symposium on Industrial Electronics, Vol. 3, 1997, pp. 851-855.
- [3]. Ge, and M. Jouaneh, P. “Tracking control of a piezoceramic actuator”, IEEE Transactions on Control Systems Technology, Vol. 4, No. 3, 1996, pp. 209-216.
- [4]. Shieh,H. J. and C. H. Hsu, “An integrator-Backstepping based dynamic surface control method for a two-axis piezoelectric micropositioning stage”, IEEE Transactions on Control Systems Technology, Vol. 15, No. 5, 2007, pp. 916-926.
- [5]. Coelho and F. A. Guerra, L. D. S. “Applying particle swarm optimization to adaptive controller”, Soft Computing in Industrial Applications, Springer, 2007.
- [6]. El-Saleh, A. A. M. Ismail, R. Viknesh, C. C. Mark and M. L. Chen, “Particle swarm optimization for mobile network design”, IEICE Electronics Express, Vol. 6, No. 17, 2009, pp. 1219-1225.
- [7]. Chen and Y. Li, X. “On convergence and parameters selection of an improved Particle Swarm Optimization”, International Journal of Control, Automation, and Systems, Vol. 6, No.4, 2008, pp.559-570.
- [8]. Shieh,H. J. Y. J. Chiu, and Y. T. Chen, “Optimal PID control system of a piezoelectric micropositioner”, IEEE/SICE International Symposium on System Integration, Vol. 1, 2008, pp. 1-5.
- [9]. El-Telbany, M. E. –S. “Employing particle swarm optimizer and genetic algorithms for optimal tuning of PID controllers: A comparative study”, ICGST-ACSE Journal, Vol. 7, Issue 2, 2007, pp. 49-54.
- [10]. Allaoua, B. B. Gasbaoui and B. Mebarki, “Setting up PID DC motor speed control alternation parameters using particle swarm optimization strategy”, Leonardo Electronic Journal of Practices and Technologies, Vol. 14, 2009, pp. 19-32.