

A.H. Abed

Department of Production
Engineering and Metallurgy,
University of Technology,
Baghdad
aseelmo1972@gmail.com

A.S. Bedan

Department of Production
Engineering and Metallurgy,
University of Technology,
Baghdad
70061@uotechnology.edu.iq

M.F. Noori

Department of Production
Engineering and Metallurgy,
University of Technology,
Baghdad
mohanad.alani2012@gmail.com

Received on: 23/10/2016
Accepted on: 08/06/2017

Study the Effect of Multilayer Single Point Incremental Forming on Tool Path Mark for AA1050 bottom plates

Abstract- Single Point Incremental Sheet Forming (SPIF) is an innovative forming approach for sheet materials. One of the most problems in products produced by incremental sheet metal forming process is the poor textures caused by the tool and tool path marks on the products, due to friction between the tool and blank material. In this study, a new method and procedures were proposed which is called (Multilayer single point incremental forming) to overcome this problem by using an insert blank beside the original one with the same material but change in thickness of top plate at 0.5, 0.7, 0.9 mm and change material or lubrication between two plates such as (polymer, grease, grease with graphite, mos2 (Molybdenum disulfide) and without lubricant). Results revealed improvement in surface quality of bottom plates when using Grease with graphite or polymer gives a better result and reduced tool path marks more than other lubricants or material, which have been used.

.Keywords- Single Point Incremental Forming (SPIF), Tool Path Marks, Surface Quality.

How to cite this article: A.H. Abed, A.S. Bedan, and M.F. Noori "Study the Effect of Multilayer Single Point Incremental Forming on Tool Path Mark for AA1050 bottom plates," *Engineering and Technology Journal*, Vol. 35, Part A, No. 6, pp. 648-652, 2017.

1. Introduction

This work presents a new study of surface quality. (SPIF) is a modern Innovative and feasible solution for the change of traditional plate metal forming operation it is a very flexible operation and does not require a dedicated die for the process as compared to other forming operations. Due to this, the lead-time as well as the price of die and tooling can be reduced. This method gives a relatively faster and inexpensive production of small chain of sheet metal components and can be utilized for forming of non-symmetric as well as symmetric parts at a wide extent of thicknesses from 100 microns up to several mm. The operation beginning from a flat sheet metal blank clamped on a sufficiently rigid lock and mounted on the table of a CNC machine [1], which may result in poor surface quality. Thus, detailed investigation of the friction effect is quite necessary for developing new methods for improved sheet surface quality and enhancing the appeal for industrial applications [2]. In single point, incremental forming there is no support for the tool and there is only support for work-piece between the two ends [3-4]. In SPIF, a clamped sheet is progressively formed under the pressing of a very

simple forming tool Figure 1.

2. Setup of Multilayer SPIF

Multilayer single point incremental forming is the idea of using two plates at the same time, as shown in Figure 2. In traditional SPIF, the surface will be affected by the high degree of relative movement between plate and forming tool. Using a multi-plate, all this sliding is only affecting on the top plate. The relative movement between the top and bottom plate is very small. The forming process in two plates at the same time will increase process forces. In most cases, it will be desirable to keep the thickness of the top plate at a minimum.

1. Geometry of the part

The geometry of the formed part is an asymmetric conical profile shape with total depth (60 mm) and diameter (120 mm) for all products as shown in Figure 3. This geometry is kept constant during all the eighteen runs in order to know and evaluate the effect of factors that used in this study on tool path marks. Figure 4 shown two plates after incremental forming.

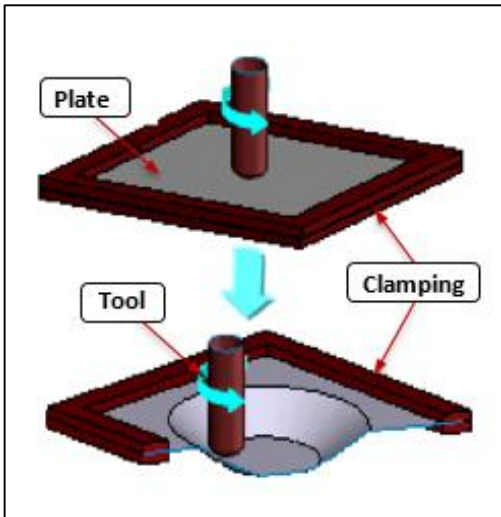

Figure 1: The SPIF working principle [5]

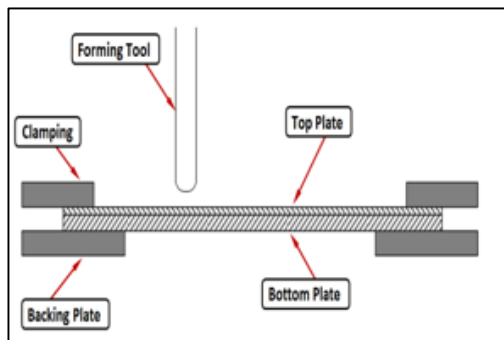

Figure 2: SPIF using two plates [6]

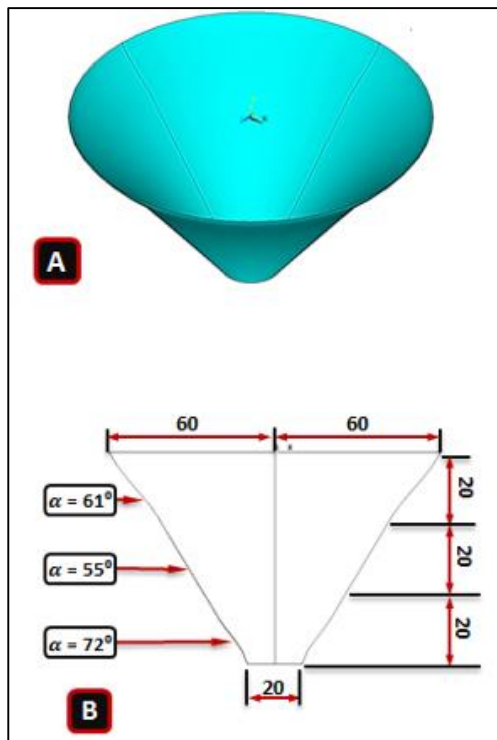

Figure 3: Dimensions details of the product that used (A) 3D CAD model (B) Side view

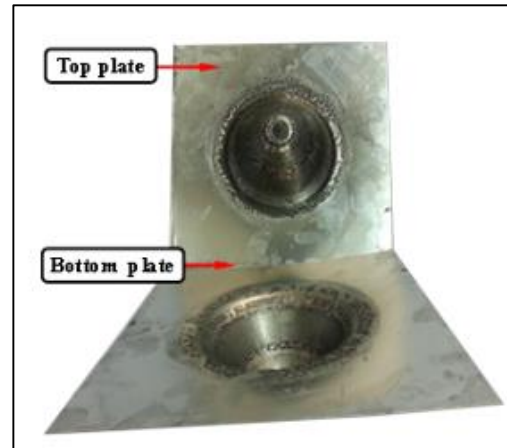

Figure 4: Two plates after incremental forming

II. Tool Path Strategies

In this study, a contour tool path (Iso-planer tool path) as shown in Figure 5 is used in all tests. This tool path is characterized by only a continuous feed rate in X- and Y directions of a deformed sheet plane. The feed rate in the Z-direction is done in the same angular position (or different) in the XY plane along a line down the side of the sheet, this line is called “incremental line”. The forming tool moves around the surrounding of the part layer by layer to be formed along the predefined tool path after the support is set under the sheet metal and extrudes the sheet metal point by point as that the local plastic deformations occur and the sheet metal forming is realized incrementally [7].

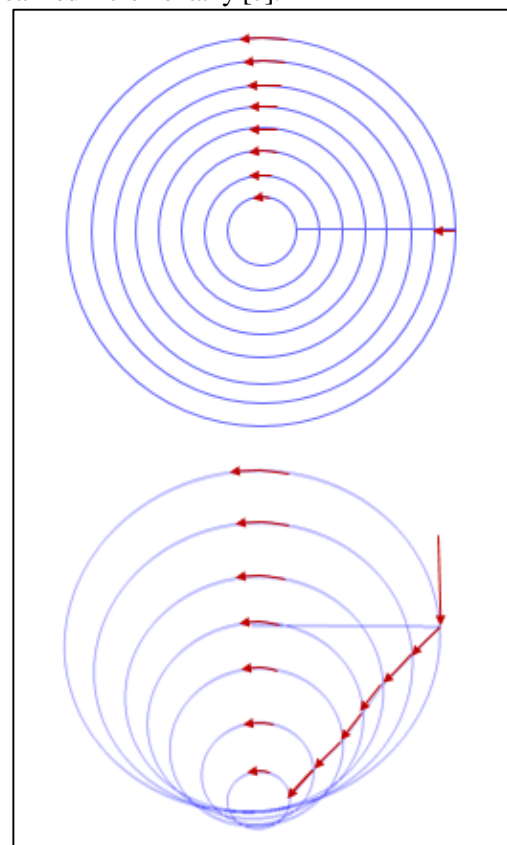

Figure 5: Iso-planer tool path

3. Experimental Work

In all experiments carried out, sheet metals of an Aluminum AA1050 alloy are used. With constant thickness of bottom plates of 0.9 mm but change in thickness of top plates at (0.5, 0.7, 0.9 mm).

The Mechanical properties of the plates that used in this work are as follows:-

Ultimate strength (109 MPa)

Yield strength (95 MPa).

Total elongation (4%).

Vickers hardness (28 HV)

The parameters of the experiments that used is constant parameter as shown in Figure 6 and variable parameter as shown in Figure 7.

I. Machine Setup

In this work, the experimental tests has been performed on 3- Axis CNC milling machine model (C-tek KM-80D) The experimental setup, technical parameters of the CNC milling machine being used are shown in Figure 8.

II. Tool Geometry

In this work the forming tool that was used in this work is Hemispherical end with diameter (12 mm) and length (100 mm) as shown in the Figure 9 this tool is manufactured from tool steel (X210) material and has HRC 58.

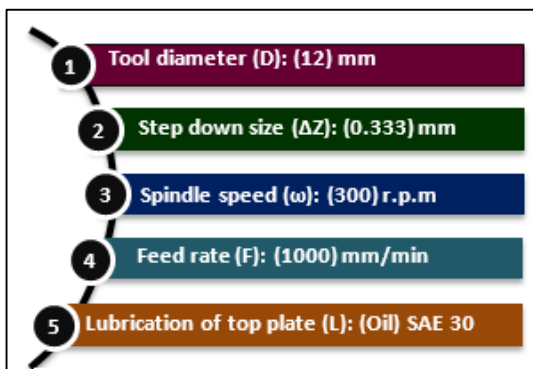

Figure 6: The proposed parameters constant

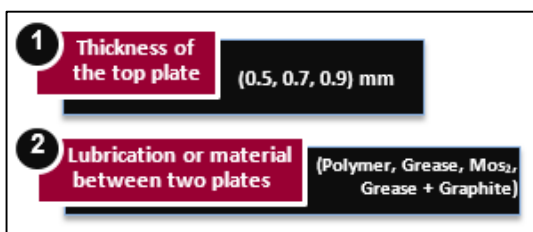

Figure 7: the proposed control parameters and their levels

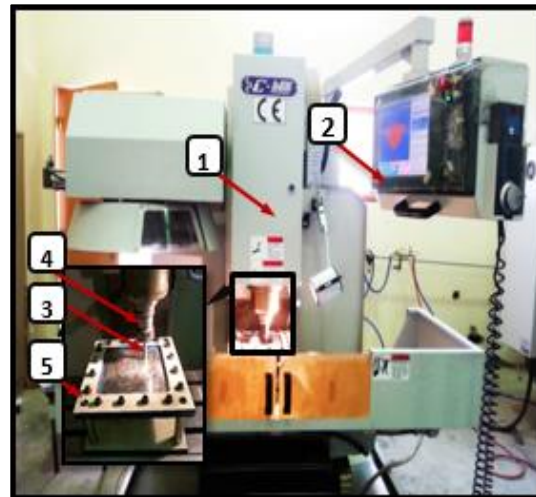

Figure 8: 3-Axis CNC milling machine used in experimental work (1) CNC milling machine (2) Machine controller (3) Forming tool (4) Tool holder (5) Forming frame

4. Results and Discussion

The effect of multilayer single point incremental forming and change in thickness of the top plate and lubrication or material between two plates on tool path marks for bottom plates and comparison with single plate at thickness 0.9 mm shown in Figure 10. Which showed an improvement in the surface texture by reducing tool path mark for the bottom plates due to increase the contact area between the two plates and therefore the stress distributed over a larger area in addition to reducing the friction between the plates compared with single plate forming process.



Figure 9: Forming tool used in experimental work





















Type of lub. or material between two plates	Thickness of Single plate (S) 0.9 mm for comparison with bottom plate	Thickness of top plate 0.5 mm and bottom plate 0.9 mm	Thickness of top plate 0.7 mm and bottom plate 0.9 mm	Thickness of top plate 0.9 mm and bottom plate 0.9 mm
W: Without Lubrication or material	 S-0.9	 W-0.5-0.9	 W-0.7-0.9	 W-0.9-0.9
P: Polymer	 S-0.9	 P-0.5-0.9	 P-0.7-0.9	 P-0.9-0.9
G: Grease	 S-0.9	 G-0.5-0.9	 G-0.7-0.9	 G-0.9-0.9
M: MoS ₂	 S-0.9	 M-0.5-0.9	 M-0.7-0.9	 M-0.9-0.9
G+GR: Grease with Graphite	 S-0.9	 G+GR-0.5-0.9	 G+GR-0.7-0.9	 G+GR-0.9-0.9

Figure 10: Tool path marks for comparison between single plate and bottom plate

5. Conclusions

In this work, the following conclusions were drawn from the study:

1. Change in thickness of top plate and lubrication or material between two plates will effect on tool path marks.
2. When increase thickness of top plate the effect of tool path marks will decrease.
3. Grease with graphite and polymer gives better result and reduce from tool path marks more than other lubrications.
4. The factor of change in thickness of top plate has the greatest effect on tool path for bottom

plate than parameter change in material or lubrication between two plates.

5. Liquid lubricants between two plates cause an increase in sliding between them during the forming process and that is effect on the quality surface where causes scratch the surfaces.

References

- [1] R. Jigar Patel, Kaustubh S. Samvatsar, Haresh P. Prajapati, Shyam S. Rangrej "Optimization of Process Parameters for Reducing Surface Roughness Produced During Single Point Incremental Forming Process", *International Journal on Recent Technologies in Mechanical and Electrical Engineering*. Vol. 2, pp. 19-23, 2015.
- [2] A. Sabree Bedan, Alaa Hassan Shabeeb and Hassan Nemaha Al-Sobyhawe "Modeling and Optimization of Machine Parameters Using Simulated Annealing Algorithm (SAA)", *Engineering and Technology Journal*, Vol. 34, Part A, No.7, 2016.
- [3] B. Lu, Y. Fang, D.K. Xu, J. Chen, H. Ou, N.H. Moser, J. Cao "Mechanism investigation of friction-related effects in single point incremental forming using a developed oblique roller-ball tool", *International Journal of Machine Tools & Manufacture*. Vol. 85, pp. 14–29, 2014.
- [4] A. Basil Abdulwahhab, "A Study of the Effect of (Cutting Speed, Feed Rate and depth of cut) on Surface Roughness in the Milling Machining", *Engineering and Technology Journal*, Vol. 33, Part A, No. 8, 2015.
- [5] R. Crina, Herghelegiu Eugen, Tampu Catalin and Cristea Ion "The Residual Stress State Generated by Single Point Incremental Forming of Aluminum Metal Sheets", *Journal of Applied Mechanics and Materials*, Vol. 371, pp 148-152, 2013.
- [6] M. Skjoedt, N. Bay, B. Endelt & G. Ingarao "Single Point Incremental Forming using a Dummy Plate-MultiPlate Forming", 2nd International Conference on New Forming Technology, Bremen, Conference proceedings, BIAS-Verlag, pp. 267-276, Sep. 20-21, 2007.
- [7] H. Zhu & Zhijun Liu & Jianhu i Fu "Spiral tool-path generation with constant scallop height for sheet metal CNC incremental forming", *International Journal of advanced manufacturing technologies*. Vol. 54, pp. 911–919, 2011.

Author's biography

Assit. Prof. Dr. Aseel Hamad Abed has PhD degree in die design in forward extrusion from University of Technology, Baghdad, Iraq in 2007. She was published more than 7 articles.

Assit. Prof. Dr. Aqeel Sabree Bedan has PhD degree in single point incremental forming process from College of Engineering, Baghdad University, Baghdad, Iraq in 2013. He was published more than 13 articles.

Mohanad Faeq Noori has M.Sc. degree in Multi-Layer Single Point Incremental Forming process from University of Technology, Baghdad, Iraq in 2016.