

**Azzad B. Saeed**

Electrical Department  
engineering, University of  
Technology, Baghdad, Iraq.  
[30065@uotechnology.edu.iq](mailto:30065@uotechnology.edu.iq)

Received on: 19/11/2017  
Accepted on: 09/08/2018  
Published online: 25/11/2018

## New Accurate Wattmeter Based on Logarithmic Amplifiers

**Abstract-** Analog Computers can realize most of mathematical equations; these equations can be solved using difference, adder, logarithmic, anti-logarithmic, integrator, and differentiator amplifiers. The logarithmic and anti-logarithmic amplifiers are the main components of the analog computers, whereas, they can convert the multiplication and division operations to addition and subtraction ones, and they can convert the exponential functions to multiplication relationships. These amplifiers depend on the non-linearity of the relation between forward current and applied voltage of the diode. All of previous types of wattmeters, measure the consumed power of a specific load or resistor by multiplying the difference voltage of that load by the current passes through it (i.e.  $P=V.I$ ). In this paper, a proposed accurate wattmeter circuit has been designed and implemented using logarithmic, anti-logarithmic, non-inverting, and difference amplifiers. The proposed circuit has been utilized for measuring the consumed power of a resistor that have any resistance value. It differs from previous conventional (analog, and digital) wattmeters due to its calculation of the consumed power for a given resistor by multiplying the voltage difference (V) across that resistor by itself once time, then the resultant value is divided by the resistance (R) value of that resistor (i.e.  $P=V^2/R$ ).

**Keywords-** Anti-logarithmic amplifier, Difference amplifier, Logarithmic amplifier, Non-inverting amplifier, Wattmeter.

**How to cite this article:** A. B. Saeed, "New Accurate Wattmeter Based on Logarithmic Amplifiers," *Engineering and Technology Journal*, Vol. 36, Part A, No. 11, pp. 1165-1170, 2018.

### 1. Introduction

All the previous wattmeters yet, calculate the consumed power for a resistor load connected in any electrical circuit, by multiplying the current passing through that resistor by the voltage difference across it ( $P=V.I$ ) [1]. The wattmeter is an electric device is utilized to measure the electrical power of any part of specific electrical or electronic circuit, which it presents the power in Watts unit. The classical (Old) wattmeter is classified as an Electro-dynamic device, that consists of two coils, the first one is the current coil, while the other is the voltage (or potential) coil, where, the last one is movable [2,3]. The current coil, should be connected in series with the given circuit terminals, while the voltage coil should be connected in parallel. The voltage coil of the analog wattmeter holds a needle, whereas, the measurement can be indicated by moving this needle over a scale. By flowing a current through the current coil, an electromagnetic field should be generated around the coil, the relation between this field and line current is direct (or forward). A resistor of high value resistance must be connected in series with the voltage coil, which is used to reduce the current flows through that coil [2,3]. The electronic wattmeter differs from the

conventional analog one, where, the first one consists of electronic components such as transistors, diodes, and integrated circuits ICs to measure direct and small amount of powers. Some of these wattmeters are capable of measure powers for frequencies higher than that used with classical one. The electronic wattmeter consists of a current to voltage converter, which translates the passing current through a given resistor to a voltage value, then the last one is multiplied by the voltage difference across that resistor by a multiplier circuit [4][5]. The modern digital electronic wattmeter is much different from previously mentioned ones; it consists of digital electronic components. In this device, the voltage and current for a specific part of any electric circuit, will be sampled thousands or even millions times at any second, then for any two corresponded voltage and current samples, they will be multiplied. The active power can be calculated by averaging these multiplied samples for a period of one cycle. The power factor can be calculated by dividing this active power by the measured Volt-Ampere VA. These wattmeters can calculate the RMS value for both voltage and current, power factor, VA, and active power (in Watts) [6,7]. The proposed circuit is different from all of previous wattmeter types by its

composing and function. As mentioned before, it calculates the power of any resistor by multiplying the potential difference across that resistor by itself once time, then the resultant value is divided by the resistance value of the same resistor. The proposed circuit consists of logarithmic, difference, anti-logarithmic, and inverting amplifiers. The operation concept of the proposed circuit can be briefly discussed as follows, at the beginning, the voltage difference across a specific resistor connected in electrical circuit is processed by a logarithmic amplifier, then the resultant output voltage is multiplied by a factor 2 with canceling of any undesired factors by a difference amplifier, the resultant voltage value is processed by anti-logarithmic amplifier, then finally, the resultant output voltage is multiplied by a factor by an Inverting amplifier to make the resultant output voltage value in positive sign and canceling any undesired factors. The output of the proposed circuit can be driven to a voltage divider circuit and then to a simple meter. The proposed circuit mainly depends upon the non-linearity relation of forward current and applied voltage of the ideal diode, which is connected to an Op/Amp to produce the logarithmic and anti-logarithmic amplifiers.

## 2. Related Works

There are several previous works and researches are related to the topic of the proposed work of this paper, they are:

In 2013, A. Mahmud *et al.* [8] have designed and hardware implemented of a high accuracy digital wattmeter. They have utilized the integrated circuits: ADE7751, Microcontroller ATMEGA32, and a 16x2 LCD display, which they are the main components of the design. The output signal of the integrated circuit ADE7751 transports the information of real power of a given load or resistor. Special calibration process extracts this real power information and then it will be displayed to LCD display by the microcontroller coding. In this work, the power has been measured by calculating the multiplication of the voltage difference across a given load by the current passes through that load. High accuracy results of the consumed power has been get by testing the proposed system of this work, which supports the success of the design, implementation, and execution. In 2015, Ilsche *et al.* [9] have proposed a design and realization of a new digital wattmeter using analog-to-digital converter, microcontroller, and logic integrated circuits.

They have measured the active power of a specific resistor or load by calculating the multiplication of the voltage difference value across that load by the current passes through it. The proposed circuit of this scientific group has the following specifications: 1) high sampling rate, 2) high accuracy, 3) high stability, 4) fast execution, 5) fast output presenting, 6) low power consumption.

## 3. Logarithmic and Anti-logarithmic amplifiers

Logarithmic amplifiers involves three main parts: Op/Amp, diode or transistor, and a resistor. They are designed and connected as shown in Figure (1), The Diode is connected between the output and inverting input of the Op/Amp as a negative feedback, while the resistor  $R_i$  is connected between (+) terminal of the input voltage  $V_{in}$  and the non-inverting input of the Op/Amp. The output voltage  $V_o$  can be obtained by pursuit the Equations (1-4) [12,13]:

The input current  $i$  can be expressed as follows:

$$i = \frac{V_{in}}{R_i} \quad (1)$$

by  $V_D = -V_o$ , the diode current can be expressed in the following:

$$i = I_D = I_s \cdot \exp\left(\frac{-qV_o}{KT}\right) \quad (2)$$

where,

$V_{in}$  : Input voltage of the proposed circuit (in Volt).

$V_D$  : Diode Potential difference (in volts).

$K$  : Boltzmann Constant equals  $1.38 \times 10^{-23}$  J/K.

$V_o$  : Output voltage of the logarithmic amplifier (in Volt).

$T$  : Temperature (in Kelvin).

$q$  : Electron charge equals  $1.6 \times 10^{-19}$  Coulomb.

$I_s$  : Diode reverse saturation current (in Ampere).  
furthermore,

$$\frac{V_{in}}{R_i} = I_s \cdot \exp\left(\frac{-qV_o}{KT}\right) \quad (3)$$

by performing the logarithm operation for both sides of Equation (3), one can obtain the final expression [12][13]:

$$V_o = -\frac{KT}{q} \ln\left(\frac{V_{in}}{I_s R_i}\right) \quad (4)$$

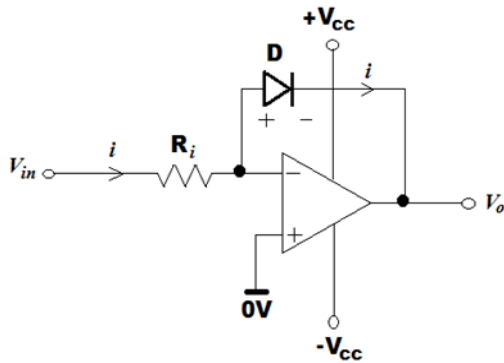

Figure1: Circuit diagram of the logarithmic amplifier

The anti-logarithmic amplifier (exponential amplifier) acts as the inverse of the logarithmic amplifier, the circuit diagram of this amplifier has been illustrated in Figure 2, as shown, the resistor  $R_f$  has been connected between the inverting input and output of the Op/Amp, which it acts as a negative feedback, and the diode has been connected between the input voltage  $V_{in}$  and inverting input of the Op/Amp. The output voltage of this amplifier can be obtained by pursuit the Equations (5-8) [14,15,16]:

$$V_D = V_{in} \quad (5)$$

The input current can be calculated as follows:

$$i = I_D = I_s \cdot \exp\left(\frac{qV_{in}}{KT}\right) \quad (6)$$

And the output voltage can be expressed as follows:

$$V_o = -i \cdot R_f \quad (7)$$

By substituting Equation (6) in (7), final expression for  $V_o$  is obtained [14,15,16]:

$$V_o = -I_s \cdot R_f \cdot \exp\left(\frac{qV_{in}}{KT}\right) \quad (8)$$

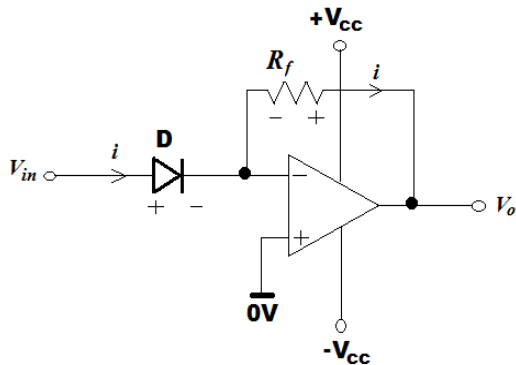

Figure 2: Circuit diagram of the anti-logarithmic amplifier

### Proposed Circuit Design

The proposed circuit consists of four main stages: logarithmic, difference, anti-logarithmic, and inverting amplifiers. The Op/Amp integrated circuit IC LM358 has been utilized for all of these amplifiers. All the Op/Amps had been supplied by a split power supply (+15, 0.-15) Volt. The circuit diagram of the proposed system is illustrated in

Figure 3.

At the beginning, The input voltage  $V_{in}$  has been applied to the input of the logarithmic amplifier that has been represented by IC<sub>1</sub> (IC LM358), this voltage represents the applied voltage across the resistor R, whereas, the power measuring has been performed on this resistor. Using Equation (4), the output voltage of the logarithmic amplifier IC<sub>1</sub> has been calculated as follows:

$$V_{o1} = -\frac{KT}{q} \ln\left(\frac{V_{in}}{I_s \cdot R_1}\right) \quad (9)$$

By, rearranging the equation one can obtain:

$$V_{o1} = -\frac{KT}{q} \ln(V_{in}) + \frac{KT}{q} \ln(I_s \cdot R_1) \quad (10)$$

The output voltage  $V_{o1}$  has been applied to input of the difference amplifier IC<sub>2</sub>, the proposed gain for this amplifier is 2, and the resistance value of  $R_3$  has been set to 2kΩ, so, the resistance value of  $R_2$  has been calculated as follows:

$$G_1 = 2 = \frac{R_3}{R_2} = \frac{2000}{R_2} \quad (11)$$

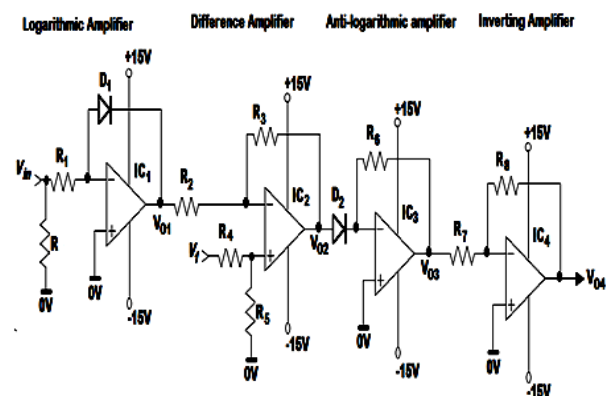

Figure 3: Circuit diagram of the proposed system

Furthermore,

$$R_2 = 1k\Omega \quad (12)$$

The output voltage of the difference amplifier  $V_{o2}$  has been calculated as follows:

$$V_{o2} = \frac{G_1KT}{q} \ln(V_{in}) - \frac{G_1KT}{q} \ln(I_s \cdot R_1) + V_1(G_1 + 1) \left( \frac{R_5}{R_4 + R_5} \right) \ln(I_s \cdot R_1) \quad (13)$$

For  $G_1=2$ ,  $R_5=2k\Omega$ ,  $R_4=1k\Omega$ ,  $R_1=1M\Omega$ ,  $V_1=1$  Volt, and  $I_s=50nA$  of diode  $D_1$  1N4148 (from data sheet), the following expression has been concluded:

$$V_{o2} = \frac{2KT}{q} \ln(V_{in}) - \frac{2KT}{q} \ln(I_s \cdot R_1) + (3) \left( \frac{2}{3} \right) \ln(I_s \cdot R_1) \quad (14)$$

Which has been solved as follows:

$$V_{o2} = \ln(V_{in}) \frac{2KT}{q} \quad (15)$$

The output voltage of the difference amplifier  $V_{o2}$  has been applied to input of the anti-logarithmic amplifier  $IC_3$ , which has been processed to generate the following output voltage:

$$V_{o3} = -(I_s \cdot R_6) \exp\left(\frac{q}{KT} \cdot \ln(V_{in}) \frac{2KT}{q}\right) \quad (16)$$

So,

$$V_{o3} = -I_s \cdot R_6 \cdot V^2 \quad (17)$$

The output voltage of the anti-logarithmic amplifier  $V_{o3}$  has been applied to input of the inverting amplifier  $IC_4$ , and the output voltage of the last amplifier  $IC_4$  has been expressed as follows:

$$V_{o4} = I_s \cdot R_6 \cdot \left(\frac{R_8}{R_7}\right) \cdot V^2 \quad (18)$$

The diode 1N4148 has been utilized for  $D_1$  and  $D_2$ , and from data sheet of these diodes,  $I_s=50nA$ , and let  $R_6=100k\Omega$ ,  $R_8=200\Omega$ ,  $R_7=R$  (which is the value of power measuring resistor that located at the input of the proposed circuit), the output voltage  $V_{o4}$  that represents the active power consumed by the load resistor  $R$  can be expressed as follows:

$$V_{o4} = \frac{(V_{in})^2}{R} \text{ (Volt)} \quad (19)$$

Which is the required expression.

Note, the output voltage of  $IC_4$  is shown in Equation (19) which is in unit Volt, which can be measured by a Voltmeter, and this voltage really represents the consumed power of the resistor  $R$  in Watt unit.

Finally, The proposed circuit has been practically implemented on printed circuit board, which has been shown in Figure 4, as illustrated, the proposed circuit can be characterized by the following features: Small size, few components, and low cost.

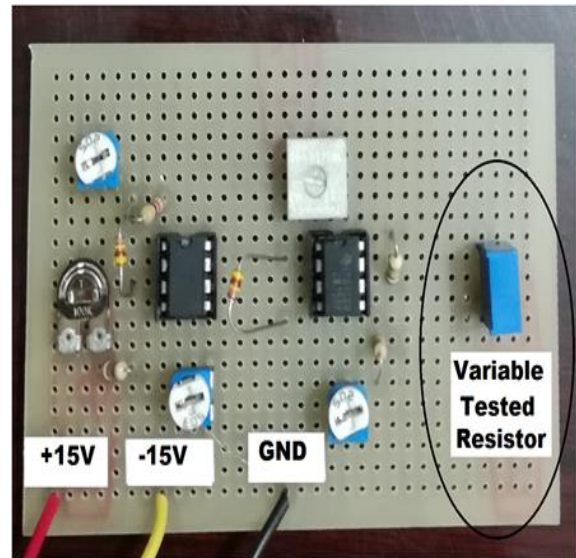

Figure 4: Implementation of the proposed circuit on printed circuit board (PCB)

### 3. Results and Discussion

Theoretical results has been presented in Figure 5, these results have been obtained by applying Equation (19), and three resistive loads have been used in this theoretical calculation, 100, 200, and 300Ω. As shown in this figure, the consumed powers of these three resistive loads have been increased non-linearly with linear increasing of the applied voltage, which supports the law of power that shown in Equation (19). The selected range of the applied voltage in this application was (0-10) Volt. As illustrated, there are three curve-lines in this figure, the upper represents the relation using 100Ω resistive load, the middle was for load of 200Ω, while the lowest was for load of 300Ω.

The output results of practical testing of the proposed circuit have been illustrated in Figure 6. This figure presents the relation between consumed power and applied voltage of the tested resistors using the proposed circuit. Three resistive loads have been utilized for this practical testing, 100, 200, and 300Ω. As shown, there are three curve-lines in this figure; the upper represents the relation using 100Ω resistive load,

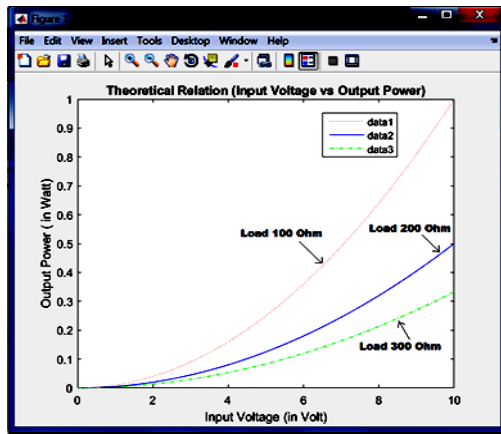

Figure 5: Theoretical relation between consumed power and applied voltage using the proposed circuit

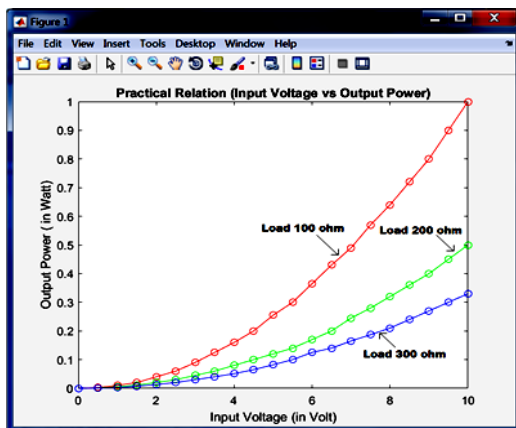

Figure 6: Practical relation between consumed power and applied voltage using the proposed circuit

The middle was for load of 200Ω, while the lowest was for load of 300Ω. For each curve-line relation, 20 measurement points has been utilized for this testing, these have been represented by circles onto and along the curve-lines, which can be accepted scientifically. As a comparison between theoretical results in Figure 5 and practical results in Figure 6, there is an accurate approximation between theoretical and practical results, although, there are several deviations in the curve-lines of the practical results that shown in Figure 6, these deviations have been occurred due to the following reasons:

1. Poor accuracy of the measurement devices.
2. Propagation phenomenon that occurs at high frequencies.
3. Mutual inductance between electronic components.
4. Stray capacitance between electronic components.

This approximation between the output results has supported Equation (19) of the consumed power law, as well as, this accurate approximation has supported the success of the design and performance of the proposed circuit.

Mahmud *et al.* [8] have presented a practical result shown in Figure 7 that represents the relation between the active output power and the difference voltage across the load resistor of 100 Ω. As mentioned before, the power measurement of this work has been achieved by calculating the multiplication of the voltage difference across the load resistor with the current passes through that resistor. As shown in Figure 7, the active power increases non-linearly with linear increasing of the applied voltage across the load resistor, which supports the power law ( $P=V.I$ ), and the applied voltage linearly varies from 0 to 5 Volt, while the real power non-linearly varies from 0 to 0.25 watt. The curve line of Figure 7 is similar to that of the upper relation between the power and applied voltage of the proposed work of this paper that shown in Figure 6. Note the accuracy of the power measurement of this work is nearly 1.7 %, while the accuracy of the proposed work of this paper is less than 1%.

Ilsche *et al.* [9] have tested their work and presented output results of the relation between the consumed power and applied voltage for a load resistance 10Ω that is illustrated in Figure 8. As shown from Figure 8, the active power increases non-linearly with linear increasing of the applied voltage, which is similar to that of the output result of testing the proposed circuit of this paper that shown in Figure 6. In this work, the applied voltage linearly varies from 0 to 7 Volt while the active power non-linearly increases from 0 to 5 watt, and the accuracy of this work reaches to nearly 1.5%, while the accuracy of the results of the proposed work of this paper is less than 1%.

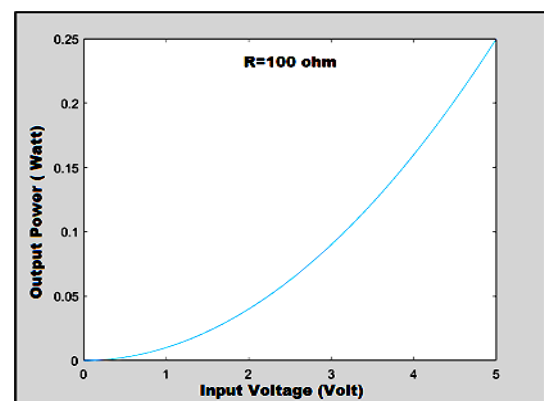
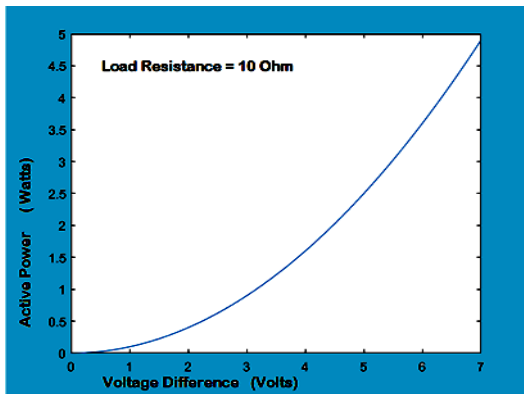

Figure 7: The result of relation between the actual power and the applied voltage of the work of Mahmud *et al.* [8]



**Figure 8: The result of relation between the actual power and the applied voltage of the work of Ilsche et al. [9]**

## 6. Conclusions

One can use the operational amplifiers in logarithmic and anti-logarithmic amplifier circuits to measure the consumed power of a specific resistor in two manners: 1) by multiplying the voltage difference across that resistor by itself one time, and then the resultant value is divided by the resistance value of the same resistor, 2) by multiplying the voltage difference across the resistor by the current passes through that resistor itself. The outputs voltage values of the logarithmic, and anti-logarithmic amplifiers depend on the exponential function of the diode current equation, where, the diode of the logarithmic amplifier is connected as a feedback for the operational amplifier, while in the anti-logarithmic amplifier, the diode is connected to the inverting-input of the operational amplifier. Using logarithmic, anti-logarithmic, adder, difference, integrator, and differentiator amplifiers, one can easily perform any differential or simple equations for any degree. The accuracy of the power measurement of the proposed circuit depends on the accuracy the resistance value of the tested load or resistor. Practically, the accuracy of the results of the proposed work of this paper has reached to less than 1%.

## References

- [1] P. Arpaia, F. Avallone, A. Baccogalupi, C. De Capua, and C. Landi, "Power Measurement," CRC Press LCC. 1999.
- [2] G. Petrecca, "Energy Conversion and Management: Principles and Applications," Springer International Publishing, Switzerland, 2014.
- [3] K. Brindley, "Starting Electronics: third edition," K. Brindley, ISBN: 07506-63863, British, 2005.
- [4] D. Vasileska and S.M. Goodnick, "Computational Electronics," Morgan & Claypool, U.S.A, 2006. [www.morganclaypool.com](http://www.morganclaypool.com).
- [5] J.C. Whitaker, "Microelectronics," Taylor & Francis Group, LCC. Second edition, ISBN-10: 0-8493-3391-1, U.S.A, 2006.
- [6] J.C. Whitaker, "The Resource Handbook of Electronics," CRC Press LLC. ISBN 0-8493-8353-6, U.S.A, 2001.
- [7] J. Luecke, "Analog and Digital Circuits for Electronic Control System Applications," Elsevier Inc., ISBN: 0-7506-7810-0, U.S.A, 2005.
- [8] A. Mahmud, T. Bin Kashem, M.I. Dewan and M.B. Upama, "Design and Hardware Implementation of a Digital Wattmeter," American Journal of Engineering Research (AJER), Vol.02, Issue.12, pp.244-251, 2013.
- [9] T. Ilsche, D. Hackenberg, S. Grauly, R. Sch, J. Schuchart, "Power Measurements for Compute Nodes: Improving Sampling Rates, Granularity and Accuracy," IEEE publishing Co., 2015.
- [10] F. Mohammed, "A New Topology of Load Network for Class F RF Power Amplifiers," Eng. &Tech. Journal, Vol.34, Part (A), No.11, 2016.
- [11] T. M. Abdul-Wahhab, "Harmonic Analysis of a Power Distribution Network in Baghdad City," Eng. &Tech. Journal, Vol.34, Part (A), No.6, 2016.
- [12] O. Bishop, "Microelectronics: Systems and Devices," O. Bishop, U.K, 2000.
- [13] T.L. Floyd, "Electronic Devices: Conventional Current Version," Pearson Prentice Hall, seventh edition, ISBN: 0-13-127827-4, U.S.A, 2005.
- [14] D.M. Kaplan and C.G. White, "Hands-on Electronics: A Practical Introduction to Analog and Digital Circuits," Cambridge University Press, ISBN-10:0-521-81536-3, 2003.
- [15] L. Sterpone, "Electronics System Design Techniques for Safety Critical Applications," Springer Science + Business Media B.V., ISBN: 978-1-4020-8978-7, 2003.
- [16] M. Tooley, "Electronic Circuits: Fundamentals and Applications," Elsevier Ltd., ISBN-10:0-75-066923-3, 2006.

## Author(s) biography

**Name: Azzad B. Saeed**

Place and date of birth: Baghdad, 1967.

Nationality: Iraqi.

Address: Baghdad, Iraq.

Workplace: Electrical Department Engineering, University of Technology.

Educational Background:

- B.Sc (Electrical Engineering, University of Technology, Iraq, 1989).
- MSc. (Electrical Engineering, University of Technology, Iraq, 2005).
- Ph.D. (Electrical Engineering, University of Technology, Iraq, 2017).