

Excitation and Governing Control of a Power Generation Based Intelligent System

Dr. Adil H. Ahmad * & Lina J. Rashad*

Received on:29/9/2008

Accepted on:2/4/2009

Abstract

Modern power systems are complex and non-linear and their operating conditions can vary over a wide range. In this work, the power system (PS) transient terminal voltage and frequency stability enhancement have been well investigated and studied through the following efforts.

- Enhancing the responses of the transient stability by adopting conventional PID controllers as an additional voltage controller with the Automatic Voltage Regulator (AVR) in the excitation system for terminal voltage, and in the governing system for frequency deviation response.

- ANN (NARMA-L2) system is proposed as an effective controller model to achieve the desired enhancement. This model after training can be called as (Identifier). This identifier follows the system behavior even in situation of high disturbances.

There are enhancement progress in terminal voltage V , and frequency deviation $\Delta\omega$ through the investigation for the three cases (without controller, with PID controller, and with NN controller) for single machine infinite bus using MATLAB- Simulink software.

Keywords: PID controller, Neural Network controller, Excitation system control, Governing system control.

السيطرة على منظومة الاثارة و التحكم في وحدة توليد القدرة بواسطة منظومة ذكية

الخلاصة

تعتبر أنظمة القدرة الحديثة لاختطية وعالية التعقيد وان شروط اشتغالها يمكن أن يتغير ضمن مجال واسع. يقدم هذا الجهد تقصي ودراسة استقرارية نظام القدرة وذلك بتحسين الأستقرارية العابرة للفولتيات والتردد بشكل تام ومن خلال الخطوات التالية.

- تحسين هذه الأستقرارية من خلال تبني المسيطر (التناسبي - التكاملية - التفاضلية) التقليدي وذلك كمسيطر احتياطي يعمل مع منظم الفولتية الأوتوماتيكي (AVR) في منظومة الإثارة لتحسين فولتية الأطراف وفي منظومة التوربين لتحسين انحراف التردد.

- لقد تم اقتراح الشبكات العصبية الاصطناعية كنموذج مسيطر من نوع (NARMA-L2) والذي يمكن ان يدرّب بشكل دقيق لكي يكون إخراج هذا المسيطر هو الإخراج الحقيقي للمنظومة (المطابق) ويتم تحسين الأداء بمتبع سلوك المنظومة حتى وان كان الأضطراب كبير .

لقد تم تحقيق تحسين استجابة فولتية الأطراف والانحراف في التردد عن طريق مقارنة وتطبيق ثلاث حالات (بدون استخدام أي مسيطر باستخدام المسيطر (التناسبي - التكاملية - التفاضلية) , و أخيراً باستخدام مسيطر الشبكة العصبية الاصطناعية حيث تم اعتماد برنامج (MATLAB) للمحاكاة وطبق على مولدة أحادية مختلفة الأحمال في منظومة الشبكة الكهربائية.

*Electrical and Electronic Engineering Department, University of Technology/Baghdad

1- Introduction

Power system stability can be defined as the tendency of power system to react to disturbances by developing restoring forces equal to or greater than the disturbing forces to maintain the state of equilibrium (synchronism). Stability problems are therefore concerned with the behavior of the Synchronous Generator (SG) after they have been perturbed. Generally, there are three main categories of stability analysis. They are namely steady state stability, transient stability and dynamic stability. Steady state stability is defined as the capability of the power system to maintain synchronism after a gradual change in power caused by small disturbances [1]. Transient state stability refers to as the capability of a power system to maintain synchronism when subjected to a severe and sudden disturbance [2]. The third category of stability, which is the dynamic stability, is an extension of steady state stability, it is concerned with the small disturbances lasting long period of time. The generators are usually connected to an infinite bus where the terminal voltages (V_t) are held at a constant value.

The study of SG control systems can roughly be divided into two main parts: voltage regulation and speed governing. Both of these control elements contribute to the stability of the machine in the presence of perturbations. There are various methods of controlling a SG and suitability will depend on the type of machine, its application and the operating conditions[3].

The AVR system has a substantial effect on transient stability when varying the field voltage to try to maintain the

terminal voltage constant. This is achieved by comparing the output voltage With a reference voltage and, from the difference, it makes the necessary adjustments in the field current to bring the output voltage closer to the required value [3]. The excitation and governing controls of the generator play an important role in improving the dynamic and transient stability of the power system.

The presence of poorly damped modes of oscillation, and continuous variation in power system operating conditions arises some limitations in the conventional controllers. These limitations have motivated research into so-called intelligent control systems. Artificial Neural Networks (ANNs) have been used in the design of nonlinear adaptive controllers with various control objectives in the field of electrical power engineering, especially for the synchronous generator excitation and governor control. The NARMA-L2 controller among the ANN family has in particular attracted attention for the control of SG and flexible ac transmission systems devices due to its powerful control capability for damping of low-frequency oscillations as well as the faster convergence speed for identifying the plant[4]. This research is focused mainly on voltage and frequency stability of SG in a typical power system using fourth order model of synchronous generator.

2- Modeling of Synchronous Generator

The overall accuracy of the power system stability is primarily decided by how correctly the Synchronous Generators within the system are modeled. The proposed simulation model

is developed as a fourth order machine time constants in order to improve the terminal voltage and frequency deviation responses [5]. With proper modeling of the synchronous machine in the power system, a better understanding of how the machine reacts under sudden large disturbances during transient conditions can be achieved and hence a better power system voltage regulator and governor controllers of the SG can be designed . Some assumptions were taken into consideration and made prior to the design of the simulation model, these assumptions are:

- The SG turbine in this model produce a constant torque with a constant speed maintained during steady state operation.
- The SG output terminals are connected to infinite bus bar that has various load changes.
- Only basic and linear models of the power system components will be used.
- All the time constants of the SG which are used in this model of all components are assumed to be the optimum time constants extracted based on the values given in Walton[5].

The stability of a SG depends on the inertia constant and the angular momentum. The rotational inertia equations describe the effect of unbalance between electromagnetic torque and mechanical torque of individual machines. By having small perturbation and small deviation in speed, the swing equation becomes [1]:

$$d\Delta\omega / dt = (1/2H) (\Delta P_m - \Delta P_e) \dots\dots (1)$$

then $d\Delta\omega / dt = d^2\delta / dt$

H = inertia constant

ΔP_m = change in mechanical power

ΔP_e = change in electrical power

$\Delta\omega$ = change in speed (elec. rad/sec)

δ = rotor angle (rad.)

Using Laplace Transformation, equation (1) becomes:

$$d\delta / dt = \Delta\omega(s) = (1/2Hs) [\Delta P_m(s) - \Delta P_e(s)] \dots\dots (2)$$

A more appropriate way to describe the swing equation is to include a damping factor that is not accounted for in the calculation of electrical power P_e . Therefore, a term proportional to speed deviation should be included. The speed-load characteristic of a composite load describing such issue is approximated by [6]:

$$\Delta P_e = \Delta P_L + K_D \Delta\omega \dots\dots (3)$$

where K_D is the damping factor or coefficient in per unit power divided by per unit frequency. $K_D \Delta\omega$ is the frequency-sensitive load change and ΔP_L is the non frequency-sensitive load change.

Figure (1) presents a block diagram representation of a load change derived from the swing equation with the aid of equation (3) or:

$$\Delta\omega(s) = [\Delta P_m(s) - \Delta P_L(s)] [1/(2Hs + KD)] \dots\dots(4)$$

Figure (2) represents a simplified block diagram of the Governor and AVR of the synchronous generator with the two feedback quantities (voltage and frequency).

The main control function of the excitation system is to regulate the generator terminal voltage V_t which is accomplished by adjusting the field voltage with respect to the variation of V_t [7].

The following proposed models are needed to study the effect of using the PID controllers and the Neural Network (NN) controller which represent on the

fourth order model of synchronous generator for terminal voltage and frequency deviation stability control and how this stability have been enhanced.

2.1 Generator Model

A fourth order model of the SG consists of a generator gain plus four pairs of pole-zero time constants can be modeled. In terms of expressing this as a transfer function, then the following equation is given[3]:

$$V_i(s)/V_f(s) = K_G \frac{(1+sT_{z1})(1+sT_{z2})(1+sT_{z3})(1+sT_{z4})}{(1+sT_{p1})(1+sT_{p2})(1+sT_{p3})(1+sT_{p4})} \dots (5)$$

There are two ways in MATLAB-Simulink to design the machine model, these are:

1. Using power system block set which is a set of ready-made [4].
2. Using blocks of transfer functions of the machine to manipulate the design model.

However, using blocks of the transfer function to represent the components in the power system is capable of having higher order machine time constants as inputs. This can be achieved by the illustration shown in Figure (3) [8,9].

Where: K_G = Gain of the generator, T_z = Time constant of the zero, T_p = Time constant of the pole, V_F = Field voltage of the SG, V_t = Terminal voltage of the SG.

2.2 Exciter model

The most basic form of expressing the exciter model can be represented by a gain K_E and a single time constant T_E :

$$V_R(s) / V_R(s) = K_E / (1 + sT_E) \dots (6)$$

V_R = the output voltage of the regulator (AVR), V_F = field voltage

The excitation system amplifier is represented similarly by a gain K_A and a time constant T_A . The transfer function of the amplifier is:

$$V_R(s) / \Delta V_e(s) = K_A / (1 + sT_A) \dots (7)$$

Where: ΔV_e = Voltage error = reference voltage (V_{ref}) - output voltage of the sensor (V_S).

2.3 Sensor Model

The terminal voltage of the SG is being fed back by using a potential transformer that is connected to the bridge rectifiers. The sensor is also being modeled, likewise as the exciter:

$$V_S(s) / V_t(s) = K_R / (1 + sT_R) \dots (8)$$

V_S = output voltage of the sensor, K_R and T_R are the gain and time constant of the sensor .

2.4 Automatic Voltage Regulator (AVR) Mode

In most modern systems, the AVR is a controller that senses the generator output voltage then initiates corrective action by changing the exciter control in the desired direction [10].

A simple AVR is created with a 1st order model of SG as shown in the Figure (4).

From this block diagram, the closed-loop transfer function of a 1st order relating the generator terminal voltage $V_t(s)$ to the reference voltage $V_{ref}(s)$ can be written as follow:

$$V_t(s) / V_{ref}(s) = \frac{K_A K_E K_G (1+sT_r)}{(1+sT_A)(1+sT_E)(1+sT_G)(1+sT_R) + K_A K_E K_G} \dots (9)$$

2.5 Turbine Model

The simplest form of model for a non-reheat steam turbine can be approximated by using a single time constant T_T . The model for turbine associates the changes in mechanical power ΔP_m with the changes in steam valve position $\Delta \epsilon_v$ is given as:

$$G_T(s) = \Delta P_m(s) / \Delta \epsilon_v(s) = 1 / 1 + sT_T \quad \dots(10)$$

2.6 Governor Model

The speed governor mechanism works as a comparator to determine the difference between the reference set power ΔP_{ref} and the power $(1/R)\Delta\omega$ as shown in Figure (5). The speed governor output ΔS_g is therefore:

$$\Delta S_g(s) = \Delta P_{ref}(s) - (1/ R)\Delta\omega(s) \quad \dots (11)$$

where R represents the drop. Speed governor output ΔS_g is being converted to steam valve position $\Delta \epsilon_v$ through the hydraulic amplifier. Assuming a linearized model with a single time constant T_g :

$$\Delta \epsilon_v(s) = (1 / (1 + sT_g)) \Delta S_g(s) \quad \dots (12)$$

The final simulation model for a 4th order SG can be developed in "Matlab" as shown in Figure (5).

Typically the excitation control and governing control are designed independently since there is a weak coupling between them, then the voltage and frequency controls are regulated separately.

The suggested conventional PID controller that can be used to enhance the output response of the AVR in the excitation system is differ from the conventional PID controller that can be used to enhance the frequency deviation in the governing system.

3- PID controller

The PID is a common sense approach to control based on the nature of error. It can be applied to wide varieties of systems. The most applications of the PID controllers in power system control are in the control circuits of power generation plants (SG), either in Load Frequency Control (LFC) as a power system stabilizer to control the load angle

variation and stability of the power system, or as an auxiliary regulating controller inserting in the Excitation Control System together with the AVR to control and enhance the terminal voltage transient stability response [11].

The three parameters that must be determined (some times, must be optimized) for the given process, to give the desirable output responses for the plant are: proportional gain, integral gain and derivative gain.

The transfer function of the PID controller looks like the following [12]:

$$C(s) = K_p + K_i / s + K_d s = (K_d s^2 + K_p s + K_i) / s \quad \dots\dots\dots(13)$$

K_p = Proportional gain, K_i = Integral gain, and K_d = Derivative gain. The error signal (e) will be sent to the PID controller, and the controller computes both the derivative and the integral of this error signal. The signal (u) just past the controller is given as:

$$u = K_p.e + K_i \int e.dt + K_d de/dt \quad \dots (14)$$

This signal will be sent to the plant, and the new output (y) will be obtained. This new output (y) will be sent back to the sensor again to find the new error signal (e). The controller takes this new error signal and computes its derivative and its integral again. This process will continuous until the desired output achieved.

A proportional controller (K_p) will have the effect of reducing the rise time and will reduce , but never eliminate , the steady –state error . An integral control (K_i) will have the effect of eliminating the steady – state error , but it may make the transient response worse .

A derivative control (K_d) will have the effect of increasing the stability of the system , reducing the overshoot , and improving the transient response .

Two PID controllers are introduced in this research, one of them is introduced in the excitation system and the other PID controller is introduced in the governing system. These PID controllers are developed to improve the dynamic response and also reduces the steady state error.

However, the use of a high derivative gain will result in excessive oscillation and instability when the generators are strongly connected to an interconnected system. Therefore, an appropriate control of derivative gain is required. The proportional and integral gains can be chosen to result in the desired temporary droop and reset time. The proposed AVR and governor system block diagram for simulating a 4th order model of synchronous generator with PID controllers is shown in Figure (6).

4- Neural Network Control

In this work, the NARMA -L2 architecture is applied with the aid of the Neural Network Toolbox of MATLAB software. The identification can be summarized by the flowing steps :

a- The first step in using feedback linearization (or NARMA-L2 control) is to identify the system to be controlled. Neural network is trained to represent the forward dynamics of the system . One standard model that has been used to represent general discrete-time nonlinear systems is the NARMA-L2 model [13]:

$$y(k+d) = N[y(k),y(k-1),\dots, y(k-n+1), u(k),u(k-1),\dots,u(k-n+1)] \dots\dots(15)$$

where $u(k)$ is the system input, and $y(k)$ is the system output and k, d, n are integral number and N is the function of the output system after identification.

b- The next step is to make the output system follows some reference trajectory

by developing a nonlinear controller of the form:

$$y(k+d) = yr(k+d) \dots\dots (16)$$

$$u(k) = G[y(k),y(k-1),\dots, y(k-n+1), yr(k+d),u(k-1),\dots,u(k-m+1)] \dots\dots (17)$$

The problem with using this controller is : Training neural network to minimize mean square error, needs to use dynamic back propagation which quite slow [14] .

One solution is to use approximate models to represent the system. The controller used in this section is based on the NARMA-L2 approximate model:

$$\hat{y}(k+d) = f[y(k),y(k-1),\dots,y(k-n+1),u(k-1),\dots,u(k-m+1)] + g[y(k),y(k-1),\dots,y(k-n+1),u(k-1),\dots,u(k-m+1)]u(k) \dots\dots (18)$$

Where the next controller input is not contained inside the nonlinearity. The advantage of this form is that controlled input make the system output follows the reference equation(16) . The resulting controller is:

$$u(k) = \frac{y_r(k+d) - f[y(k),y(k-1),\dots,y(k-n+1),u(k-1),\dots,u(k-n+1)]}{g[y(k),\dots,y(k-n+1),u(k-1),\dots,u(k-n+1)]} \dots\dots(19)$$

Using this equation directly can cause realization problems, because must determine the control input based on the output at the same time, i.e:

$$y(k+d) = f[y(k),y(k-1),\dots,y(k-n+1),u(k),u(k-1),\dots,u(k-n+1)] + g[y(k),\dots,y(k-n+1),u(k),\dots,u(k-n+1)]u(k+1) \dots\dots (20)$$

Figure (7) shows the block diagram of NARMA-L2 controller together with the reference model, the plant, and the controller.

Consider the Matlab-Simulink, then the NARMA-L2 controller block can be copy

from the NN toolbox block [15]. This copy part is introduced to the main simulation model of the 4th order SG of figure (5). Figure (8) is referred to block diagram of the proposed AVR/governor system synchronous generator with NARMA-L2 controller.

5- The simulation Results

This section is focusing on the simulation results of the SG model under transient response with various load change. MATLAB program simulation method is adopted to simulate different cases related to terminal voltage and frequency responses of a fourth order model of SG. The model is inserted in the Simulink diagram and run firstly for the case without controller to calculate values of overshooting and settling time from the output response. To improve this response then a PID controller is introduced and then the NARMA-L2 controller is examined.

a) results for 0.6 p.u. load change without controller

Using the simulation model for the AVR and governing system of the 4th order SG(Fig .5) for 0.6 p.u. load change without controller then, the simulation results for terminal voltage (V_t), frequency deviation ($\Delta\omega$) are illustrated in Figure (9) and Figure (10) respectively .

The period of simulation in the frequency deviation step response($\Delta\omega$), and the terminal voltage (V_t) is set as 30 seconds, and 1.14 second respectively so as to verify that there are no further oscillations. In Figure (10), the response for $\Delta\omega$ oscillates for a period of 14.03 seconds before settling down to zero deviation. There is an overshoot error occurring at 1.6 seconds. The ideal response is to keep the deviation (oscillation) as close to zero as possible at the minimum period of time.

b) Simulation results with PID controller

In this section two PID controllers are added to the plant. Figure (11) illustrates the simulation model of a 4th order SG with two PID controllers, one unit of PID is in the governor part and the other in the excitation part.

It is very interesting to investigate the effects of each of PID controllers parameters $K_p, K_i,$ and K_d on the terminal voltage response that exist in the excitation system only .

Tuning the PID controller by setting the proportional gain K_p to 1, K_i to 0.5, and K_d to 0.005, then the frequency deviation step response $\Delta\omega$ has similar response to that for Figure (10). The response for terminal voltage is improved as illustrated in Figure (12) for 0.6 p.u load hange.

The overshoot is decreased to 3.1 p.u. .Also, the time taken for the terminal voltage to reach the value of 1 p.u. is now 0.8 seconds. It's found that these settings of $K_p, K_i,$ and K_d don't produce a good overall response.

From these responses and refer to tuning method, the best values of the PID controller parameters for the excitation and governing systems are selected as: $K_p=1, K_i=2, K_d=0.005$.

Then the new response for terminal voltage (V_t) with PID controller is illustrated in Figure (13) for load change of 0.6 (p.u.).While in a similar way, the best values of $K_p, K_i,$ and K_d of the PID controller in the governing system are set to be : 0.8, 0, 0.6 respectively.

The new simulation results for frequency deviation ($\Delta\omega$) response with PID controller is illustrated in Figure (14).

c) Simulation results with NNC

In this case, the NARMA-L2 controller for prediction and control the SG to enhance terminal voltage response in the

excitation system is examined. Figure(15) illustrates simulation system of SG with NNC. The controlling steps and output response is discussed in the following section.

Return to the Simulink model and start the simulation by choosing the start command from the Simulation menu. As the simulation runs, the plant output and the reference signal are displayed. Figure (16) shows the terminal voltage response for the 4th order SG model using NN. The frequency response is similar to that response with PID controller because this NNC is exactly exist in the excitation system and we know that the excitation and governing control are designed independently that mean there is a weak coupling between them.

d) Comparison Results

It is interesting to display a comparison response for 0.6 p.u. load change with different types of controllers, it can be summarized as follows:

- The enhancements of the transient responses of V_t are very clear as shown in Figure (17). From which one can deduced that, the artificial intelligent controller, type NARMA-L2 has the best transient response than others.
- Also, the enhancements of the transient responses are obviously appeared in Figure (18) which illustrates the frequency deviation responses of the 4th order SG model for 0.6 p.u. load change without controller and with PIDC.

It's seen from figure (18) that the PID controller is highly improved the frequency deviation step response.

The overall enhancements results of the settling time and overshoot which being a measures for the V_t transient stability enhancements, are illustrated in Table (1).

e) results for different load changes

The overall enhancements results of the settling time and overshoot for

different load changes are well investigated for the previous cases. It has been noticed that the load change has no effect on the terminal voltage response but it has affecting the frequency deviation stability as illustrated in Table(2).

6- Conclusions

The main conclusions of this work can be summarized as follows:

- 1- Building simulation model for SG, speed governor and exciter voltage regulator for SMIB system under study enables to treat the problem (transient state power system stability) with much ease and comfort.
- 2- Due to the weak coupling relationship between the AVR and AGC of the synchronous generator controls systems, the voltage and frequency controls are regulated separately that mean any controller in the excitation system will not affect governing system and vice versa.
- 3- The high settling time and overshoot values, for the transient responses of the obtained terminal voltage and frequency deviation results are due to the selection of the PID gains (parameters) by an accurate tuning method.
- 4- When excitation and governing systems are tested for various load changes, these changes in the load did not affect the output response of the excitation system that mean excitation system is always the same as at no load but it has an effect on frequency response.
- 5- The proposed Neural Network Controller gives excellent results. The terminal voltage transient stability response enhancement through the obtained results are remarkable and comparable with respect to others. By this controller, the generator terminal voltage profile and the generator transient stability response are improved.

References

- [1] IEEE/CIGRE Joint Task Force on Stability Terms and Definitions, "Definition and Classification of Power System Stability", IEEE Transactions on Power Systems, Vol. 19, No. 2, pp. 1387-1401, May 2004.
- [2] Kundur, P., "Power System Stability and Control", McGraw-Hill, 1994.
- [3] Cirstea, M. N., Dinu, A., Khor, J. G., Cormick, M. M., "Neural and Fuzzy Logic Control of Drives and Power Systems", Linacre House, Jordan Hill, 2002.
- [4] Park, J. W., Harley, R. G., Venayagamoorthy, G. K., Jang, G., "Dual heuristic Programming Based Nonlinear Optimal Control for a Synchronous Generator", School of Electrical and Computer Engineering, Georgia Institute of Technology, USA, 2007.
- [5] Walton, A., "Characteristics of Equivalent Circuits of Synchronous Machines", IEE Proc. Electr. Power Appl., vol. 143, No. 1, pp. 31-40, January 1996.
- [6] Saadat, H., "Power System Analysis", McGraw-Hill Inc., 1999.
- [7] P. W. Sauer and M. A. Pai, "Power Systems Dynamics and Stability", Prentice Hall, 1998.
- [8] Sedaghati, A. R., "A PI Controller Based on Gain-Scheduling for Synchronous Generator", Faculty of Electrical Engineering Tafresh University, Tafresh, IRAN, VOL.14, NO.2, 2006.
- [9] MATLAB User Guide Version 1, "Power System Blockset for use with Simulink", electronic copy from <http://www.mathworks.com> visited on 14 Feb 2006.
- [10] Anderson, G., "Dynamics and Control of Electric Power Systems", ETH Zurich press, March 2003.
- [11] IEEE Std 421.4™-2004 (Revision of IEEE Std 421.4-1990), "IEEE Guide for the Preparation of Excitation System Specifications", The Institute of Electrical and Electronics Engineers, USA, NY, 2004.
- [12] Goodwin, G. C., Graebe, S. F. and Salgado, M. E., "Control System Design", Santa Maria Press, Valparaiso, Chile, 2000.
- [13] Becerra, V. M., "Process Control Simulation using Simulink", Sept. 2000, Updated for Matlab 6.5 – June 2003.
- [14] Mehpotra, K. and Mohan, C. K., "Elements of Artificial Neural Networks", proceeding Japan text book pp.41, 2001.
- [15] Narendra, K. S. and Parthasarathy, K., "Identification and Control of Dynamical Systems Using Neural Networks", IEEE Transactions on Neural Networks, Vol. 1, No. 1, March 1990.
- [16] Natic, M. A., "Neural Networks Toolbox for use with SIMULINK", user's guide, The MathWorks Inc., 1997.

Table (1) Terminal voltage response for 0.6 p.u. load change without controller , with PID controller, and with NNC

	<i>Type of controller</i>	Settling time (ts) (sec.)	Overshoot (p.u)
Terminal voltage (Vt) response of a 4th order model SG for 0.6 p.u. load change	<i>Without</i>	1.14	+ 4 -0.82
	<i>PID</i>	0.2	+3.2 +0.35
	<i>NNC</i>	0.028	+2.4 0

Table (2) Freq. Dev. response for various load changes

	<i>Type of controller</i>	Settling time (ts) (sec.)	Overshoot (p.u)
Freq. Deviation response of a 4th order model SG for 0.6 p.u. load change	<i>Without</i>	14.03	+0.03 -0.04
	<i>PID</i>	10	+0 -0.03
Freq. Deviation response of a 4th order model SG for 0.3 p.u. load change	<i>Without</i>	14	+0.0342 -0.024
	<i>PID</i>	11	+0.0155 -0.0182
Freq. Deviation response of a 4th order model SG for 0.8 p.u. load change	<i>Without</i>	14.25	+0.029 -0.051
	<i>PID</i>	10	0 -0.025

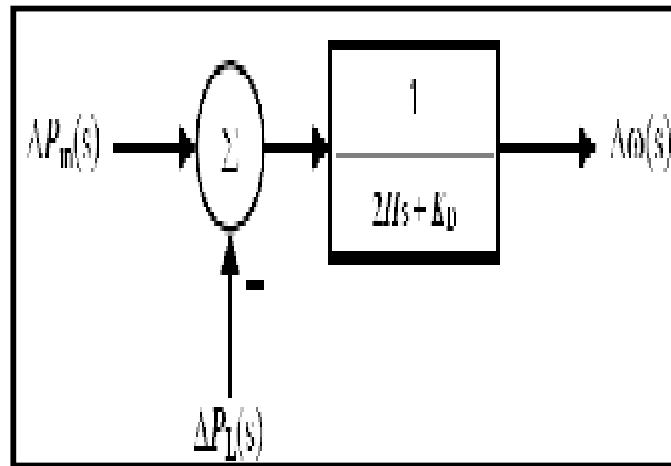

Figure (1) Block diagram of a load change model.

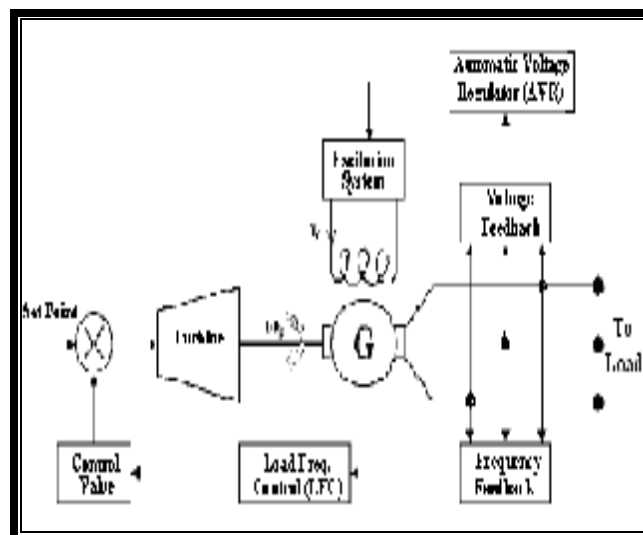

Figure (2) Block Diagram of Governor and AVR of the SG [7].

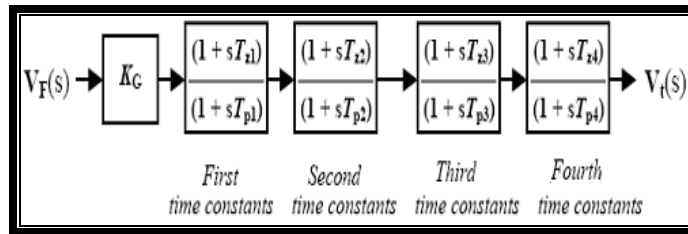

Figure (3) Block diagram representing a 4th order SG time constants model

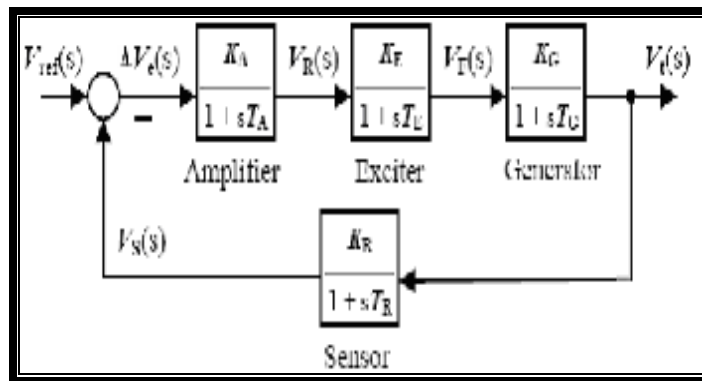

Figure (4) Block diagram of a simple AVR [11]

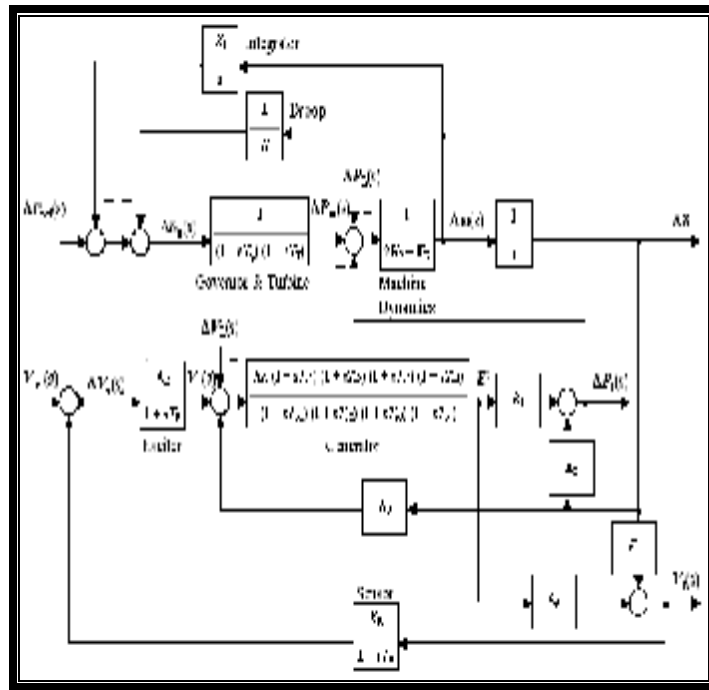

Figure (5) Simulation model for the 4th order synchronous generator time constants

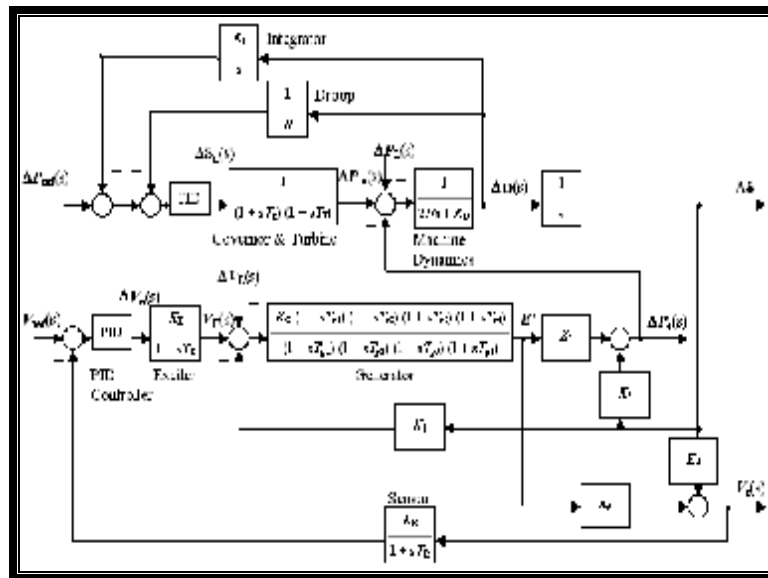

Figure (6) Block diagram of the proposed AVR and governor system with PIDC

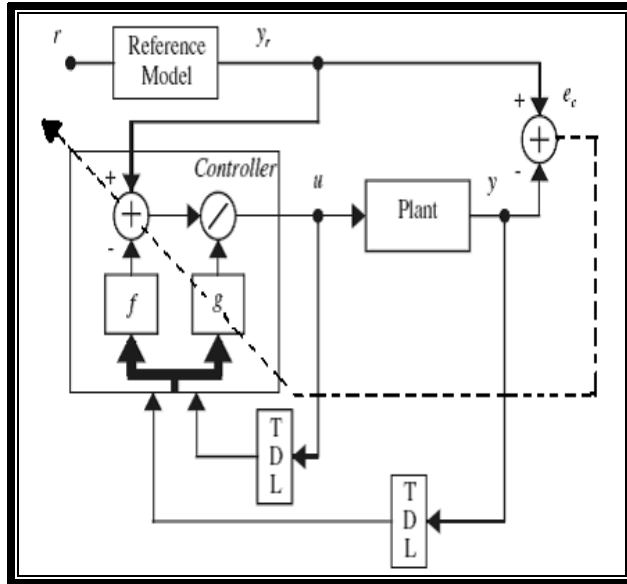

Figure (7) The block diagram of NARMA-L2 with the reference model and plant

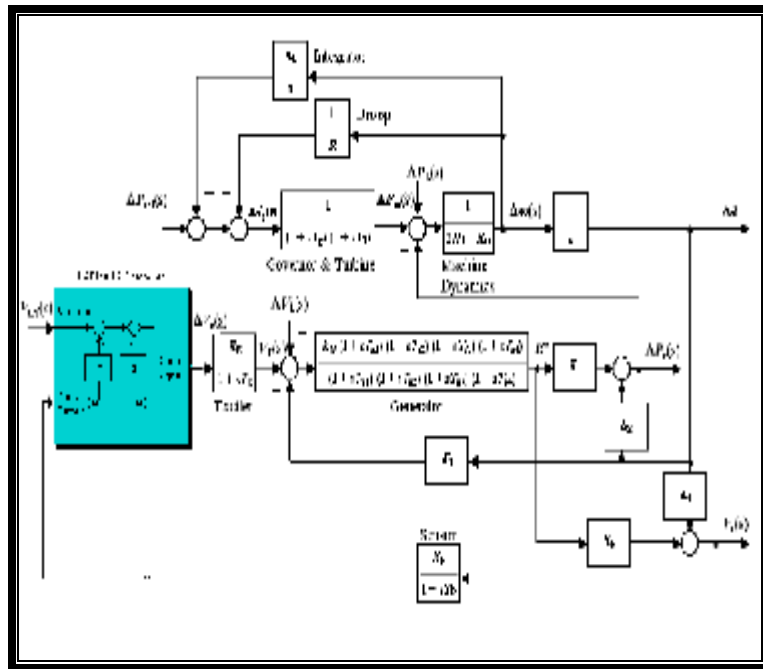

Figure (8) The proposed AVR/ governor system with NARMA-L2 controller

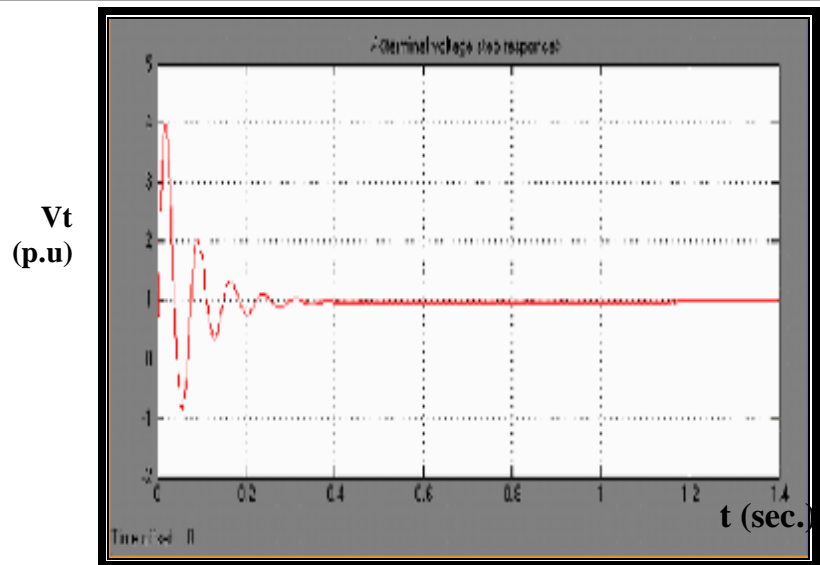

Figure (9) Terminal voltage (V_t) step response for 0.6p.u load change

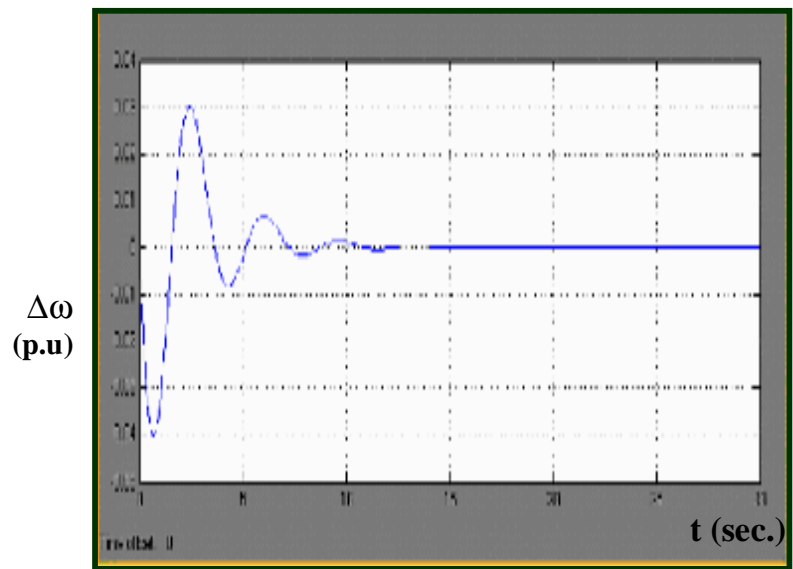

Figure (10) Frequency deviation ($\Delta\omega$) for 0.6p.u load change

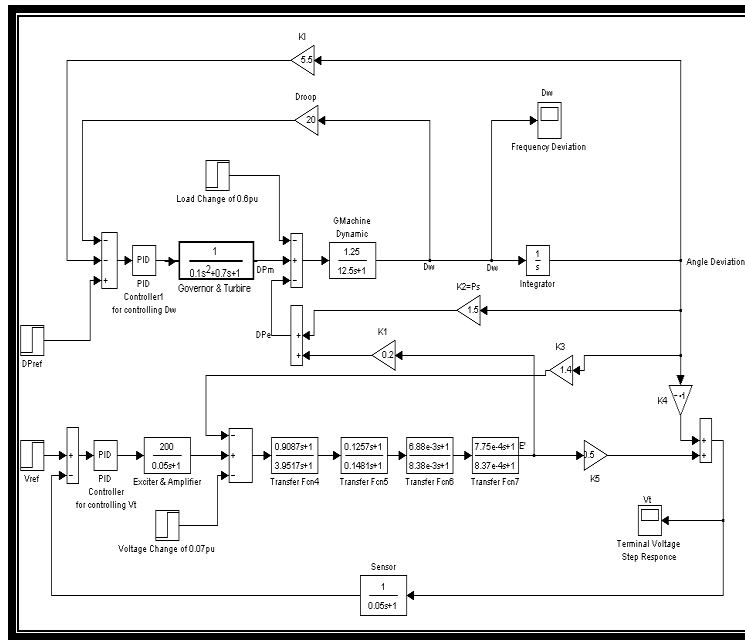

Figure (11) Simulation Model for the 4th Order SG with PID Controller

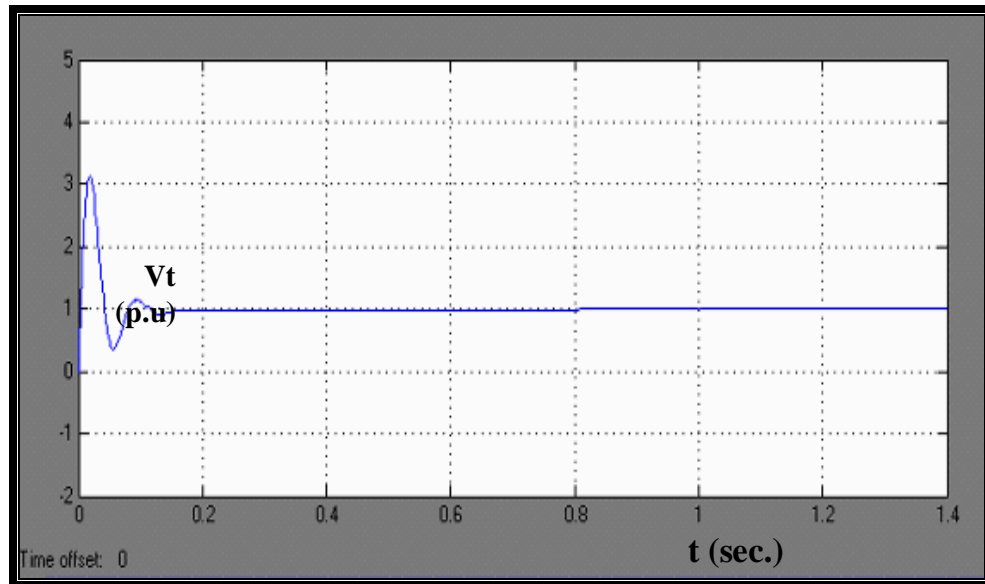

Figure (12) Terminal voltage when $K_p = 1, K_i = 0.5, \text{ and } K_d = 0.005$

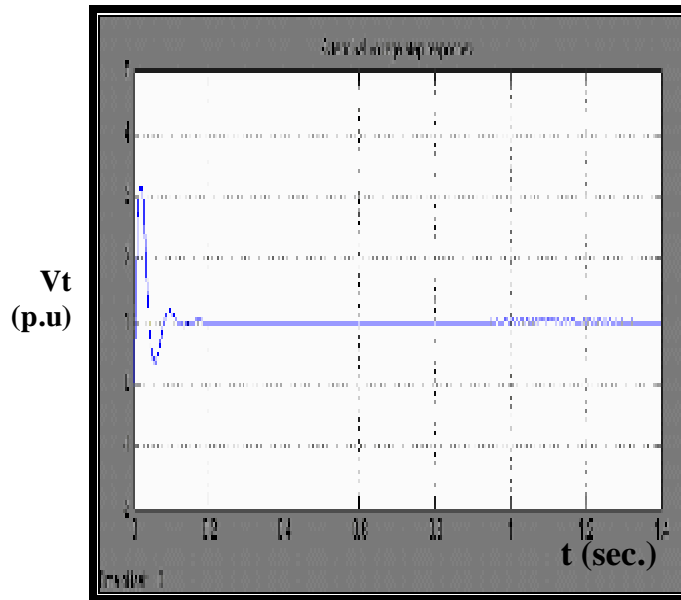

Figure (13) V_t step response for 4th order model with PID controller

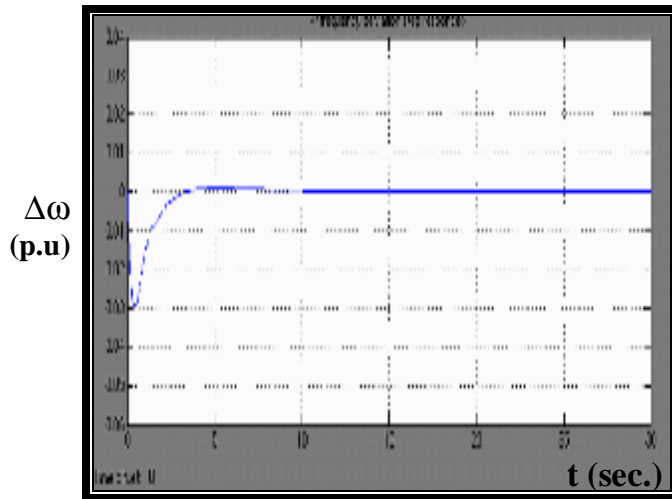

Figure (14) Frequency deviation ($\Delta\omega$) step response for 4th order model with PID controller

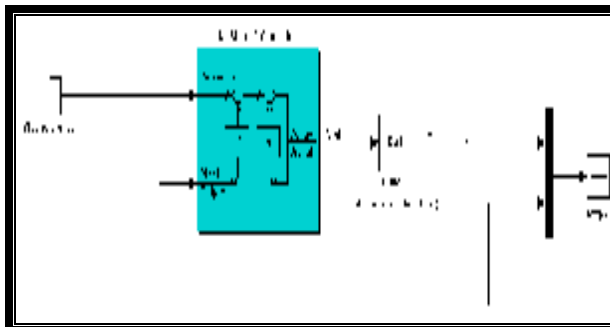

Figure (15) Simulation system of SG with NNC

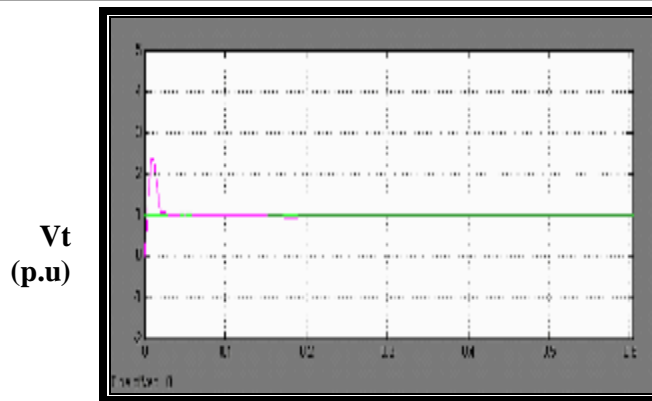

Figure (16) Terminal voltage (V_t) step response for 4th order model with NNC

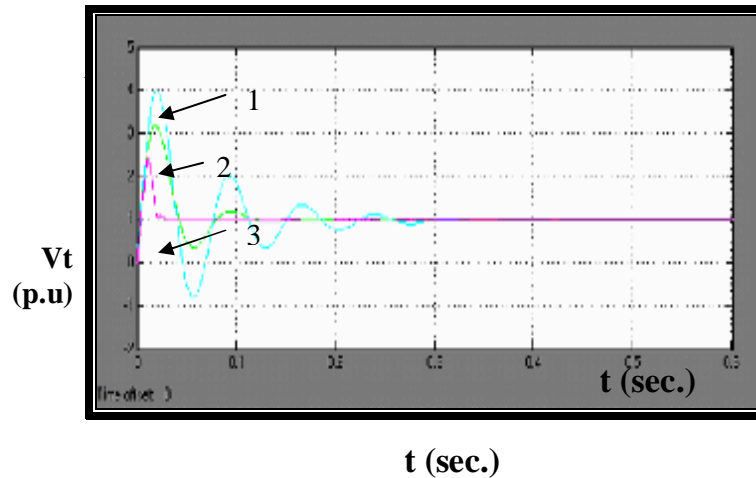

Figure (17) V_t transient responses of the 4th order SG model for 0.6 p.u. load change with different types of controllers

Where:

- 1- Terminal voltage response without controller.
- 2- Terminal voltage response with PID controller.
- 3- Terminal voltage response with NNC.

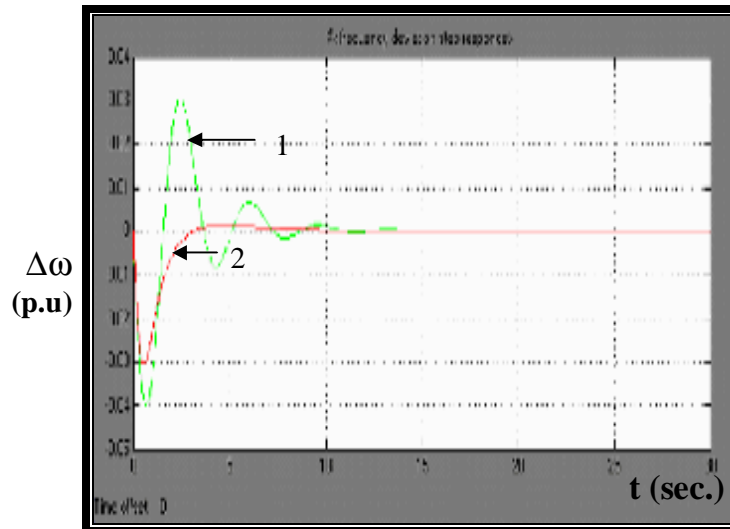

Figure (18) Freq. Deviation ($\Delta\omega$) step responses of the 4th order SG model for 0.6 p.u. load change .

Where:

1. Frequency Deviation step response without controller.
2. Frequency Deviation step response with PID controller.