

Experimental and Theoretical Study of Square Deep Drawing

Dr.Karem Muhsin Younis * & Adil Shbeeb Jaber*

Received on: 9/2/2011

Accepted on: 21/7/2011

Abstract

This work aim to study the effect of process parameters used in square deep drawing operation such as ; die and punch profile radius, blank size, blank shape, on produced cup wall thickness, strain distribution across the wall of the drawn part, punch force, earing shape and height of the drawn cup. 3-D model of square cup (41.4mm by 41.4mm), and 0.7 mm thickness from Low carbon steel (AISI 1008), has been developed. Because of the symmetry in the specimen geometry, only one fourth portion of the model was needed to be analyzed using finite element method, a commercial available finite element program code (ANSYS 11), is used to perform the numerical simulation of the deep drawing operation, and the numerical results of earing shape were compared with the experimental work. In this work, three types of blank shape (circular, square, and octagonal), with different sizes, four types of punch profile radii of 3, 5, 6, and 7mm and three types of die profile radii of 3, 5, 7mm have been chosen to form a square cup. The results show that, excessive earing will appear in the square cup when square blank was used, due to excessive material in the corner and minimum material in the flat side, and when using octagonal blank which have an equivalent surface area to the square blank, the earing in the cup corner is reduced because of extraction of the excessive material from the corner of the blank. The best results were obtained from the circular blank, according to useful drawing height and earing.

Keywords: Square Deep Drawing; Finite Element Method; Earing.

دراسة عملية ونظرية لسحب مربع عميق

الخلاصة

يهدف هذا البحث الى دراسة تاثير متغيرات العملية في عملية السحب المربع العميق مثل نصف قطر تقوس القالب والخزامة، حجم وشكل الغفل على كل من سمك الجدار للقدح المنتج، وتوزيع الانفعالات على جدار القدح، قوة اللازمة للخزامة، شكل التاذن ولارتفاعات للقدح المسحوب. تم تمثيل باستخدام نموذج ثلاثي الأبعاد (3-Dimensional) لكأس مربع ($41.4\text{mm} \times 41.4\text{mm}$)، وبسمك 0.7mm من فولاذ منخفض الكربون (AISI 1008)، وبسبب التناظر في الشكل الهندسي للنموذج تم دراسة ربع واحد من نموذج فقط وذلك باستخدام طريقة العناصر محدودة التي تم تنفيذها باستخدام برنامج (ANSYS11) الخاص بتقنية العناصر المحددة، والنتائج العددية لشكل التاذن قورنت مع العمل التجريبي. في هذا العمل، ثلاثة أنواع من أشكال الإغفال الأولية (دائري، مربع، وثماناني الأضلاع)، بإحجام مختلفة، أربع أنواع من خزامات Punch وبانصاف أقطار تقوس للحافة $3, 5, 6, 7\text{mm}$. مع ثلاث أنواع من قوالب Die وبانصاف أقطار تقوس للحافة $3, 5, 7\text{mm}$ هي اختيرت لتشكيل قدح مربع. بينت النتائج ان تاذن زائد سيظهر في

* Production Engineering and Metallurgy Department, University of Technology/ Baghdad

الكأس المربع عندما استعمال غفل مربع الشكل، بسبب تواجد مادة زائدة في الزوايا والمادة قليلة في الجانب المستوي للغفل المربع، وعندما استعمال غفل ثماني الأضلاع والزوايا، التاذن في زاوية الكأس سينخفض بسبب انتزاع المادة الزائدة من زوايا الغفل المثلث. ومن النتائج التي حصلنا عليها تبين ان أفضل النتائج عند استخدام إغفال دائرية، وفقا لارتفاع السحب المفيد و التاذن.

Introduction

Sheet metal parts are one of the predominant commodities in various engineering applications. Among the manufacturing of these sheet metal parts, deep drawing is an extensively used press working process. In a deep drawing process, an initially flat sheet or a blank, usually controlled by a blank-holder, is forced into and/or through a die by means of a punch to form the final component. Earing is one of the major defects observed in the deep drawing process. It is the formation of a wavy edge on the top of a drawn cup that necessitates extensive trimming to produce a uniform top. Earing can be directly correlated with the planar anisotropy (i.e., the variation of the plastic properties with the orientation in the plane of the sheet) [1].

Since a number of investigators have studied the drawing process, the current exposition here will focus only on the researches concerning the square deep drawing and earing defect associated that operation.

In (1965), Wright [2] investigated the phenomenon of earing in deep drawing process for different materials (aluminum, brass, mild steel). It was found that the ears of deep drawn cups appear to develop in the direction of maximum r -value (Lankford coefficient).

Koga and Paisarn (1979) [3] investigated the effect of tool radii on the limit drawing ratio of square cups during deep drawing for AZ31

magnesium alloy sheets. It is shown that increase in corner radius of the punch will increase the formability of square cups due to the improve in the metal flow in the corner of the die.

Hwang [2003][4] analyzed the influence of the blank shape in rectangular cup drawing process experimentally. A rectangular cup drawing test has been carried out to determine the optimum blank shape for various stainless steel sheet blank shapes. The results of the research, which determine the optimum blank shape for stainless steel through rectangular cup drawing experiments.

Chen et al [2003][5] was studied The formability of square cup drawing of magnesium alloy AZ31 sheets by using the experimental approach and the finite element analysis, The finite element software (PAM STAMP) was employed to perform the analysis and the four-node shell element was used in the simulations. Both the tensile tests and the forming limit tests at various temperatures ranging from room temperature to 400 C° were performed, which indicate an inferior formability of AZ31 sheets if formed at room temperature. However, the formability could be dramatically improved when the AZ31 sheet is stamped at elevated temperatures.

Vahdat et al [2006][6] was proposed an algorithm which uses an iterative process to arrive at the optimum draw bead contour, each iteration involves a finite element simulation (LS-

DYNA3D) to generate a deformed shape from a draw bead contour. A shape error measure is used to generate adjustments, which are used to modify the draw bead contour for the next iteration. The effectiveness of the method has been demonstrated with two test problems, optimal draw bead contours have been produced for both circular and square cups. The number of iterations involved is reasonable. The method's simplicity coupled with its effectiveness makes it a very viable procedure for ear minimization in practical deep drawing problems.

Yasar et al [2008][7] investigate the impact of the blank holder plate on wall thickness, cup depths, tearing and wrinkling in deep square sheet drawing process. Wall thicknesses of cups drawn experimentally by means of the fixed bhf (blank holder force) ranging from (0.5Mpa-25Mpa). It is observed that wall thickness of square cups drawn gets thinner towards the punch profile region and thickenings occur towards the mouth section. Wrinkles appear in aluminum materials of AA5754-O at (bhf) of 1.3MPa and lower whereas tears break out at (bhf) exceeding 18MPa. The depth of the cup drawn increases in direct proportion with the force applied by the blank holder plate on the sheet. Earing in the square cup starts to increase at forces of 8MPa and over.

F. Ayari et al [2009] [8] deal with the FEA (finite element analysis) of the sheet metal forming process that involves various nonlinearities. The goal is to develop a parametric study that can lead mainly to predict accurately the final geometry of the sheet blank and the distribution of strains and stresses and also to control various forming defects, such as

thinning. The numerical FEM (finite element method) simulations of the square cup deep drawing process were conducted with the ABAQUS (Explicit commercial code), and then compared with experimental results, to check the validity of the results computed by deep drawing simulations, the influence of some important numerical parameters is investigated. These parameters refer to the FE mesh, constitutive model, the friction behavior.

Numerical simulation

For simulating the deep drawing processes, commercial FEA software ANSYS11.0 was used, in which the "Newton-Raphson" implicit approach was employed to solve nonlinear problem. In this approach, the stroke steps on punch are defined explicitly over a time span. Within each step, several solutions (substeps or time steps) are performed to apply the displacement gradually. At each substep, a number of equilibrium iterations are performed to obtain a converged solution.

The 3-D 8-node structural solid element of SOLID45 was used for workpiece (blank). The tool set (punch, die and blankholder) was modeled as rigid bodies. Element sizes are controlled by controlling the division specification of lines. Mesh density of the blank and tools affect the accuracy of the results. So the meshes in the blank are finer. The most important portion of the tool whose mesh density affects the accuracy and reliability of the results is its arc segment and the meshes of this portion are finer than other portions.

The movement of the punch was defined using a pilot node; this node was also employed to obtain the

drawing force during the simulation. The degrees of freedom of the pilot node represent the motion of the entire rigid surface.

Automatic contact procedure in ANSYS11.0 was used to model the complex interaction between the blank and tooling. For rigid (tool set)-flexible (blank) contact, target elements of TARGE170 were used, to represent 3D target (tool set) surfaces which were associated with the deformable body (blank) represented by 3D 8-node contact elements of CONTA174. The contact and target surfaces constitute a "contact pair", which was used to represent contact and sliding between the surfaces of tool set and workpiece (blank).

A deep drawing model was created. Due to the symmetry in the specimen geometry, constraints and boundary conditions, only a one fourth portion of the model needed was analyzed. The finite element model of the sheet material and drawing die is shown in Figure (1).

For simplifying the simulation of the deep drawing processes, the following assumptions were made: temperature of workpiece (blank) remained constant, no heat transfers between workpiece and tool set; the dies were rigid, the upper die (punch) moved down at constant speed (60mm/min) during the forming process and the lower die (cavity) was stationary.

Bilinear Isotropic Hardening (BISO) option uses the von Mises yield criteria coupled with an isotropic work hardening assumption. This option is often preferred for large strain analyses. Combine BISO with Hill anisotropy options to simulate more complex material behaviors. The

principal axes of anisotropy coincide with the material (or element) coordinate system. Elasto-plastic constitutive model with isotropic strain hardening was used to simulate the sheet response. The elastic behavior was taken to be linear and the plastic response was modeled using Hill's 1948 yield criterion (anisotropic).

Experimental work

in this work, Punch and die were designed and built to produce square cup, Figure (2) Schematic representation of rig deep drawing tooling. They are made from tool steel, and were machined by milling machine. after machining, these components were polished in order to obtain finer surface finish as shown in Figure (3) . The rigid square punch is 40 mm by 40 mm, the profile radius is 5 mm and punch corner radius is also 5 mm which gives radial clearance of $(1.1t_0)$ at assembly with the die which has a flat surface with a square hole 41.55 mm by 41.55 mm, the profile radius is 5 mm and the die corner radius is 5 mm. Deep drawing experiments are carried out to obtain square cup, where deep drawing die is placed on the hydraulic press which has a capacity of (220KN). After putting blank on the blank holder surface, die will drop towards the punch, and this means inverted drawing die use. Drawing speed equal to (60mm/min) was selected to draw for the low carbon steel material. The blank holding force were determined as the minimum to prevent wrinkling by trial and error, they were (15 KN) for low carbon steel material.. In order to study the strain distribution within the cup during drawing operation, a grid pattern of (5, 10, 15, 20, 25, 30, 35, mm) radii circles, was printed (along 8

intersecting lines, 45 degree apart) on undeformed blanks, by using mechanical grid marker as shown in Figure (3). In order to measure the cup wall thickness, the drawn cup was divided into two parts by using a diamond saw as shown in Figure (3). Digital thickness micrometer and tool microscope were used to measure the cup wall thickness and the changes in the grid circles during the deformation. Cup thickness and the length of distorted grid radius were measured along the 8 intersecting lines.

Thickness strain and radial strain distribution were derived from the measured thickness and deformed grid circles using the incompressibility condition by using these equations:

$$\text{Radial strain } \epsilon_r = \ln (R_i/R_o)$$

$$\text{Thickness strain } \epsilon_t = \ln (t_i/t_o)$$

and then hoop (circumferential) strain by using equation

$$\text{Hoop strain } \epsilon_h = -(\epsilon_r + \epsilon_t)$$

where

- R_i instantaneous radius of the grid circular.
- R_o initial radius of the grid circular.
- t_i instantaneous thickness of the cup wall.
- t_o initial thickness of the cup wall.

Finally, Figure (3) shows the sample of completely drawing cup. Three types of blank shape (circular, square, and octagonal). Circular blank with diameters ($D=80\text{mm}$), and the side length of the square blank are ($L=70\text{mm}$), while the inscribe of octagonal blank within circle diameters are ($R_O=83\text{mm}$) and thickness of 0.7mm for all blanks used as shown in Figure (4)

Results And Discussions

The numerical analysis was carried out using the Hill's model as implemented in ANSYS 11 commercial finite element code, because the Hill's model takes the r -value in account. Figure (5) shows the comparison of cup shape between Hill's and experimental for different blank shapes. Mild steel materials have the Lankford values of r_0 , r_{45} , and r_{90} for 1.395, 1.165, and 2.00 respectively, and tool geometry with (punch and die profile radius in mm) [rp5rd5], (blank diameter in mm) D80, (blank holder force in KN) bhf15, (coefficient of friction) $\mu 0.1$, (punch speed in mm/min) v60, and different blank shapes were chosen to predict the earing defects on deep drawing process by FEM, and then the numerical results were compared with the experimental.

Figure (6) shows the effect of initial blank shape on the earing pattern during square deep drawing processes, in this work three different blank shapes (circular, square, and octagonal) are used, all blanks have the same volume to study the effect of the blank shape on the earing defect in the final cup. However, a square cup has flat and curved sides, the plastic deformation characteristics are not uniform around the periphery of the square. It is noted that from the figure, when the square blank is designed for square deep drawing excessive earing is shown in the square cup corner since the metal flow has been difficult in the corners of the cup, whereas flat sides flow in better condition compared to the corner zones, the material begins to flow at the regions where it flows easily. At these regions, outer edge of

the square blank is closest to the die cavity. As a result, the difference between the height of cup in the corner direction and the height of cup in the flat side for the square cup when square blank is used is 17.219 mm. Therefore, the square blank shape must be modified to give smaller contact surface at the corners, therefore use octagonal blank in which the distance between corners of the die and inclined sides of the blank constitutes the shortest distance, it is found when this type of blank shape is used, there is less earing because of extraction of the excessive material from the corners of the blank. The presence of little material makes the material flow easily, whereas the flat side of the die metal may flow rapidly and leave loose metal in the part of the cup wall, but the earing appears at (27° from rolling direction) due to additional material in this location. Therefore, the useful drawing height is higher than that attained in the square blank. Moreover, another blank shape is taken when the blank is prepared circular therefore more useful drawing height has been obtained, and the earing occurs in the corners slightly. Figure (7) shows the effect of blank shape on cup wall thickness along 0° , 45° , and 90° with respect to RD (rolling direction). It is clear from the figure that initial blank thickness at the region of flat bottom face of the punch is small, change of thickness occurs, this is because the flat face of the punch is in contact with blank, and due to the drawing force. At the punch corner thinning will occur, this happens due to stretching by tensile stress. Then, these types have caused rapid increase in thickness toward the top. It is obvious that the thickening increases with square blank

at 0° and 90° from RD, i.e. (flat side of the die) because of smaller width of square blank in these directions and due to easy flow in this direction, but in the corner of the cup (45° from rolling direction) excessive thinning occurs in corner cup because of excessive material in this location of the square blank that makes it hard to draw easily. Whereas using octagonal blank the thinning reduces in cup corner (45° from RD) because of presence of little materials that makes material flow easily.

Generally, the circular blank will give better distribution of thickness along the cup, better useful drawing height and least earing.

Figure (8) shows the effect of circular blank size on drawing load of drawn cups for mild steel(1008AISI) blanks of diameters (78, 80, and 82mm), select this diameters to produce cup without wrinkling and fracture based on primarily experiments, and tool geometry was (punch and die profile radius in mm) [rp5rd5], (blank holder force in KN) bhf15, (coefficient of friction) $\mu 0.1$, (punch speed in mm/min) v60, As expected punch force increases as the blank size increases. The deformation resistance of the blanks increases as its volume increases and consequently energy is needed for drawing deformation.

Figure (9) show the strain distribution over the cup wall of completely drawn part for condition above along rolling direction theoretically. It is clear that the radial strain (ϵ_x) increases with decreasing the die profile radius, this indicates increase in the thinning with decreasing the die profile radius. For the thickness strains, it is seen from this figure, the

value of thickness strain at the cup bottom is zero, may be due to friction which prevents any deformation of the metal under the punch head, and hence there is no thickness change observed. Thickness strain (ϵ_Y) starts to change at the punch profile radius region, the value of thickness strain becomes negative (reduce in thickness) as a result of tension stress in this area and the maximum reduction occurs at the smallest die profile radius, then it becomes positive at the cup wall (increase in thickness) because of compressive stress in this direction. It continues to increase to reach maximum value at the cup rim. Hoop strain is zero at cup bottom where no deformation occurs, afterwards it becomes positive at the cup corner (expand in circumference) due to tension stress in this area and the higher value occurs with small die value ($r_d=3$ mm), then it begins to decrease towards cup wall to have negative value (shrinkage in circumference) because of the compression applied in this direction and it continues to decrease to reach a maximum value at the cup rim. Effective strain (ϵ_Q) increases with decreasing die profile radius and reaches the maximum value at cup rim.

Conclusions

1. Almost earing defect is concentrated at cup corners.
2. The position of ear which appears along the perimeter of the square cup is varied according to initial blank shape, planar anisotropy, and conditions which when effect on the flow rate of the metal.
3. Earing will appear at cup corner (45° from rolling direction) although this direction has lower r -value.

4. Excessive earing will appear in the square cup when using square blank, excessive material in the corner and minimum material in the flat side. When using octagonal blank, the earing in the cup corner is reduced.

5. The worst results are obtained from the square blank used, the best results are obtained from the circular blank, according to useful drawing height and earing.

6. The punch force increases with increasing blank size.

References

- [1] R. K. Saxena , P. M. Dixit , "*Finite element simulation of earing defect in deep drawing*", Int J Adv Manuf Technol ,45:p. 219–233,2009.
- [2] J. C. Wright, "*The Phenomenon of Earing In Deep Drawing*", Sheet Metal Industries, Vol. 42, No. 458, November, p. 814-831,1965.
- [3] N. Koga, R. Paisarn, "*Effects of Tool Radius on Formability During Deep Drawing of AZ31 Magnesium Alloy Sheets*", Journal of Japan Institute of Light Metals, Vol. 53, No. 4, p. 152-156,1979.
- [4] W. B. Bae ,H. Y. Kim and C. Hwang," *Experimental determination of the optimum blank shape in rectangular cup drawing* " , International journal of Korean Society of Precision Engineering Vol. 4, No. 1, 2003.
- [5] F-K. Chen , T.B Huang, C.K Chang , "*Deep drawing of square cups with magnesium alloy AZ31sheets*"International Journal of Machine Tools & Manufacture 43,p. 1553_1559, 2003.
- [6] V. Vahdat, S. Santhanam, and Y. W. Chun, "*A numerical investigation on the use of draw bead to minimize ear formation in deep drawing*", Journal of Materials

- Processing Technology, 176,p. 70-76,2006.
- [7] H. Ü. Demirci, C. Esner, M. Yasar," *Effect of the blank holder force on drawing of aluminum alloy square cup: Theoretical and experimental investigation*", Journal of Materials Processing Technology 2006,p. 152 –160, 2008.
- [8] F. Ayari, T. Lazghab, E.

Bayraktar," *Parametric finite element analysis of square cup deep drawing*", Archives of Computational Materials Science and Surface Engineering, Volume 1,Issue 2 ,2009.

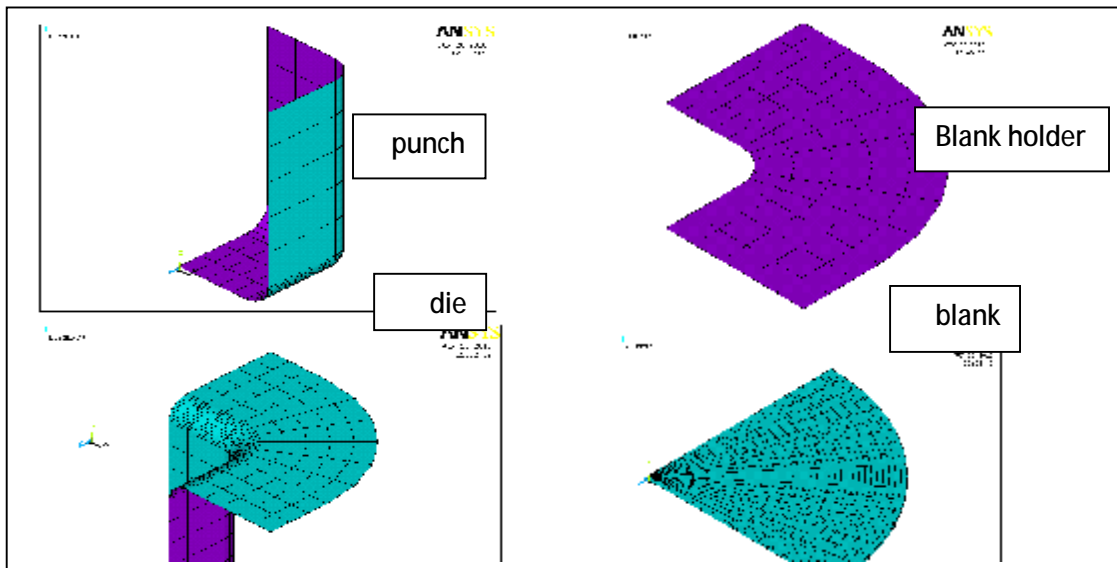

Figure (1) Finite element model of the sheet material and drawing die.

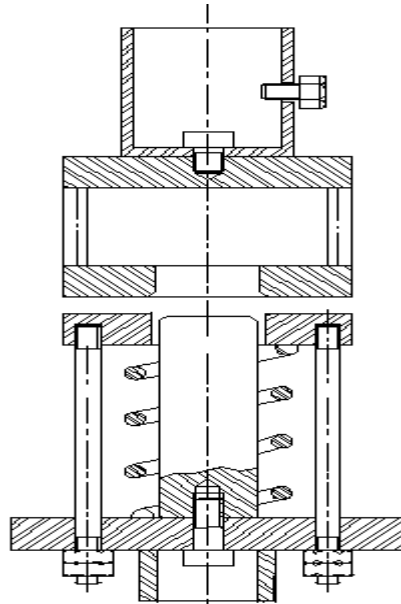

Figure (2) Schematic representation of rig deep drawing tooling.

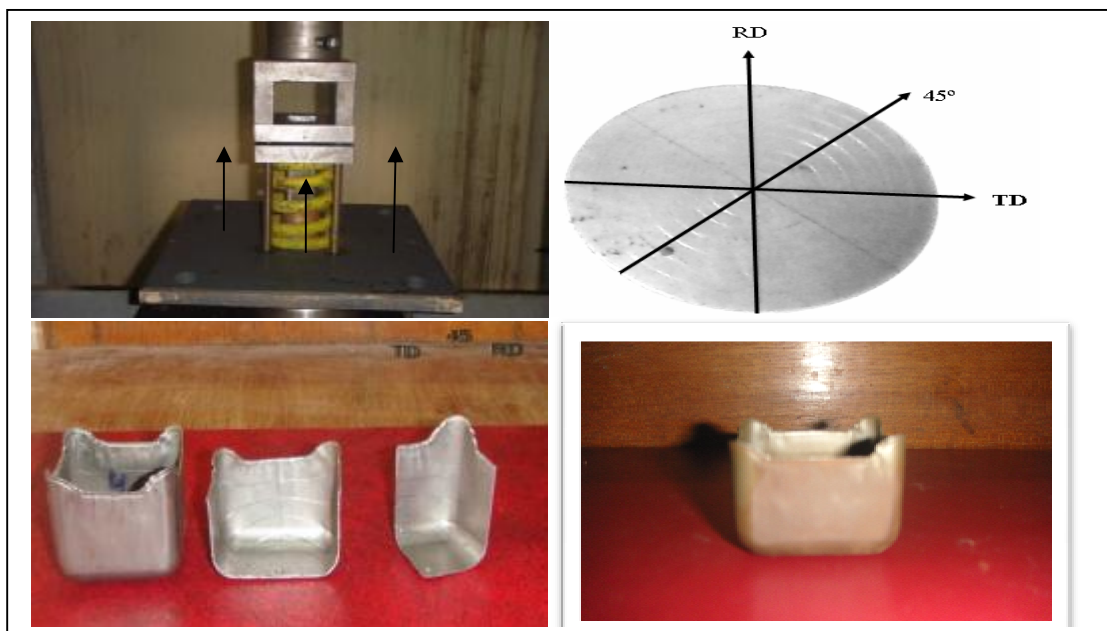

Figure (3) drawing die used in the experimental work, grid circles printed on undeformed blank, sample of divided cup and completely drawn parts.

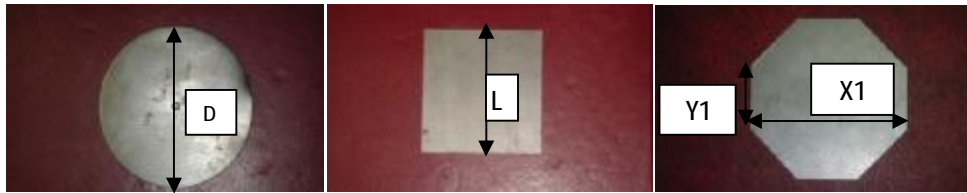

Figure (4) shape of used blanks, where $D=80\text{mm}$ (diameter of circular blank), $L=70\text{mm}$ (side length of square blank), $X1=77\text{mm}$, $Y1= 32\text{mm}$ (dimensions of octagonal blank).

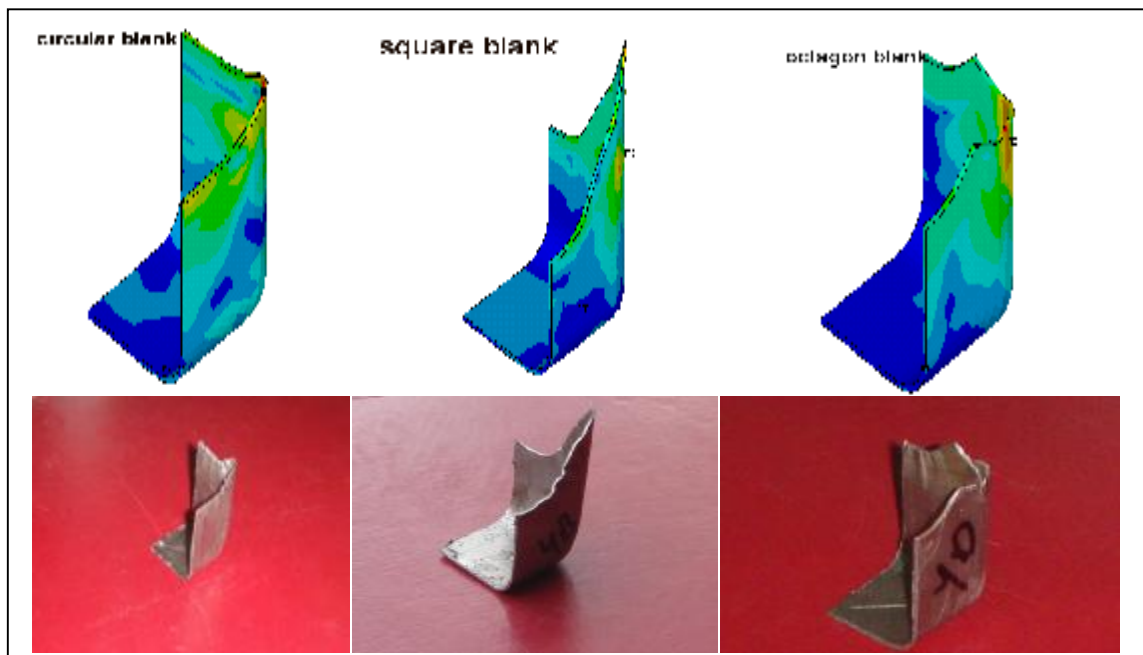

Figure (5) Comparison of cup shape (earing shape) between FEM model and experimental work. (rd5,rp5, $\mu 0.1$,v60,bhf15).

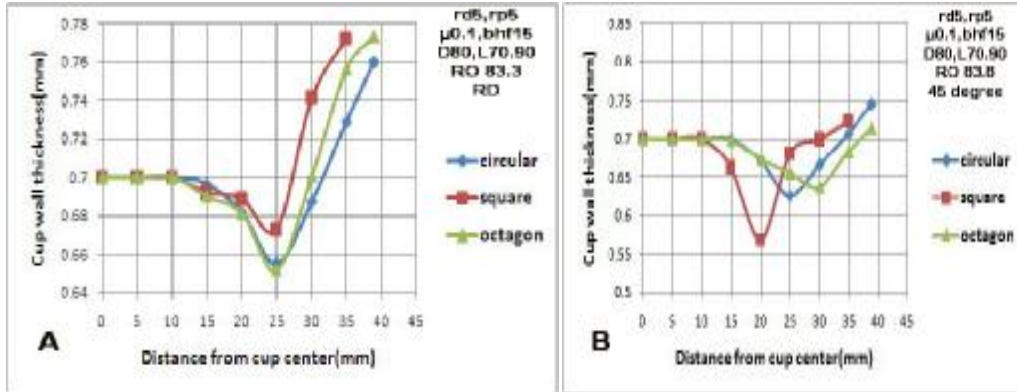

Figure (6) The effect of the blank shape on the cup height.

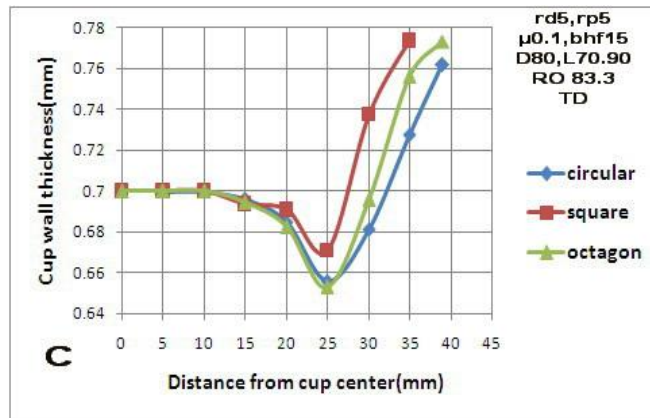

Figure (7) The effect of blank shape on the cup wall thickness along, A) rolling direction, B) 45° from rolling direction, C) transverse direction.



Figure (8) The effect of blank size on punch load.

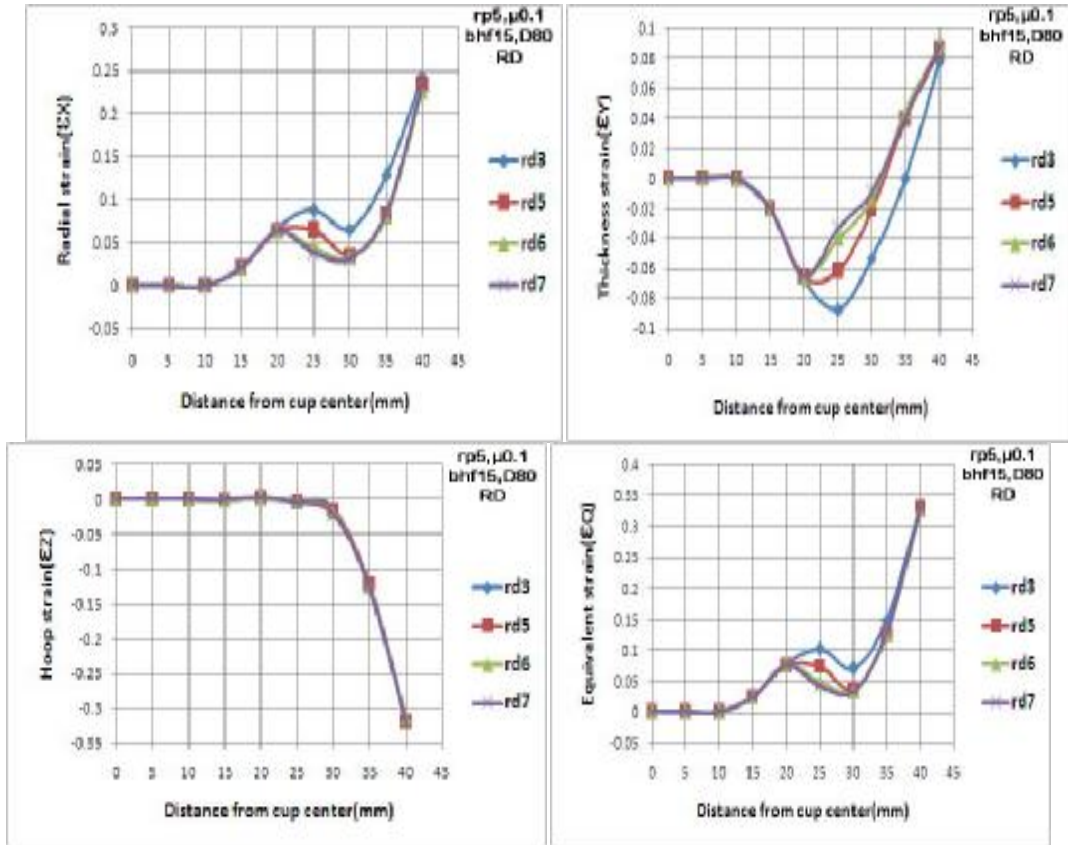

Figure (9) The effect of die profile radius on strain distribution along rolling direction.