

## Particle Swarm Optimization and Genetic Algorithm for Tuning PID Controller of Synchronous Generator AVR System

Fadhil A. Hassan\* & Lina J. Rashad\*

Received on: 29/11/ 2010

Accepted on: 3/11/ 2011

### Abstract

Proportional Integral Derivative (PID) controllers are widely used in many fields because they are simple and effective. Tuning of the PID controller parameters is not easy and does not give the optimal required response, especially with non-linear system. In the last two decades many intelligent optimization techniques were taken attention of researchers like: Genetic Algorithm (GA) and Particle Swarm Optimization (PSO) techniques. This paper represented the non-linear mathematical model and simulation of the synchronous generator with closed loop PID controller of AVR system. The traditional PID tuning technique is proposed as a point of comparison. Two of intelligent optimization techniques: PSO and GA are proposed in this paper to tune the PID controller parameters. The obtained results of the closed loop PSO-PID and GA-PID controller response to the unit step input signal shows excellent performance with respect to the traditional trial and error tuning of the PID controller.

**Keywords:** PID Controller, Particle Swarm Optimization, Genetic Algorithm, Synchronous Generator AVR.

### أمثلية الحشد الجزيئي والخوارزمية الجينية لتوليف المسيطر التناسبي التكاملية التفاضلي للسيطرة على نظام منظم الجهد الأوتوماتيكي للمولد المتزامن

#### الخلاصة

المسيطر التناسبي التكاملية التفاضلي واسع الاستخدام في عدة مجالات وذلك لبساطته وكفاءته. ولكن عملية توليف معاملات المسيطر ليست بسيطة ولا تعطي الاستجابة المثلى وخصوصاً مع الأنظمة اللاخطية. في العقدين الأخيرين عدد من التقنيات الذكية جلبت أهتمام الباحثين للحصول على الاستجابة المثلى، ومن هذه التقنيات: نظام الخوارزمية الجينية و أمثلية الحشد الجزيئي والتي أصبحت ادوات قويه للحصول على الاستجابة المثلى. يقدم هذا البحث النموذج الرياضي اللاخطي للمولد المتزامن مع مسيطر الحلقة المغلقة التناسبي التكاملية التفاضلي على نظام منظم الجهد الأوتوماتيكي. تم توليف المسيطر باستخدام الطريقة التقليدية لأستخدامها في مقارنة النتائج. يقترح هذا البحث استخدام تقنيتين ذكيتين لتوليف المسيطر التناسبي التكاملية التفاضلي وهما: الخوارزمية الجينية وأمثلية الحشد الجزيئي. أعطت النتائج المستحصل عليها لأستجابة الحلقة المغلقة للنظام أداءً ممتازاً لأشارة الخطوة مقارنة بطريقة المحاولة والخطأ التقليدي.

### 1. Introduction

The PID controller is considered as the workhorse of the industrial control process, because of its high features like: simple operation algorithm, relative easy adjusted, and it has reliably produced

excellent control performance. Therefore, it has been familiar with researchers and practitioners within control community. In spite of its widespread use, one of its main disadvantages is that there is no

\*Electrical Engineering Department, University of Technology/Baghdad

efficient tuning method for this type of controller [1]. Several tuning methods have been proposed for the tuning of process control loop. The most popular tuning methods are: Ziegler-Nichols, Cohen-Coon, and Astragglund. Unfortunately, in spite of this large range of tuning techniques, the optimum performance cannot be achieved [1].

Several new intelligent optimization techniques have been emerged in the past two decades like: Genetic Algorithm (GA), Particle Swarm Optimization (PSO), Ant Colony Optimization (ACO), Simulated Annealing (SA), and Bacterial Foraging (BF) [2]. Due to its high potential for global optimization, GA has received great attention in control system such as the search of optimal PID controller parameters. The natural genetic operations would still result in enormous computational efforts. PSO is one of the modernHeuristics algorithms, it was developed through simulation of a simplified social system, and has been found to be robust in solving continuous non-linear optimization problems [2].

In this paper, a tradition method for tuning PID controller of non-linear synchronous generator AVR system control is represented. Then, the GA and PSO based methods for tuning the PID controller parameters are proposed as a modern intelligent optimization algorithm.

## 2. Modeling and Simulation of Synchronous Machine

Figure (1) shows the synchronous generator stator and rotor windings in the dq-axis model; it's obviously that the effect of the field winding appears only in the d-axis, whereas the effect of the damper winding is equivalent to the rotor cage winding of an induction motor, which appears in both dq-axis circuits [3]. The mathematical description of the synchronous machine has two main problems: first, is the complex 3-phase represented differential equations, and second, is the time varying mutual inductance between stator and rotor winding through dynamic response of the SG [4]. Simply, the first problem can be solved by using axis transformation to transfer the 3-phase parameters and quantities (like: voltage, current, flux...) to 2-phase parameters, which called Park's transformation or, Park model of SG. In which all stator quantities are transferred from phase a, b and c into equivalent dq axis new variables. Equations (1 to 4) show the approximate Park's transformation by neglecting the zero sequence parameters: [3, 4]

$$P(\theta) = \sqrt{\frac{2}{3}} \begin{bmatrix} \cos(\theta) & \cos(\theta - \frac{2\pi}{3}) & \cos(\theta + \frac{2\pi}{3}) \\ \sin(\theta) & \sin(\theta - \frac{2\pi}{3}) & \sin(\theta + \frac{2\pi}{3}) \end{bmatrix} \quad (1)$$

So ,

$$\begin{bmatrix} V_q^s \\ V_d^s \end{bmatrix} = |P(\theta)| \cdot \begin{bmatrix} V_a \\ V_b \\ V_c \end{bmatrix} \quad \dots (2)$$

$$\begin{bmatrix} I_q^s \\ I_d^s \end{bmatrix} = |P(\theta)| \cdot \begin{bmatrix} i_a \\ i_b \\ i_c \end{bmatrix} \quad \dots (3)$$

$$\begin{bmatrix} \Psi_q^s \\ \Psi_d^s \end{bmatrix} = |P(\theta)| \cdot \begin{bmatrix} \Psi_a \\ \Psi_b \\ \Psi_c \end{bmatrix} \quad \dots (4)$$

Where:

$\theta$  : is the instantaneous phasor angle.

$P$  : is the transformation matrix "eq. (1)".

$V_a, V_b, V_c$  : 3-phase supply voltages.

$i_a, i_b, i_c$  : 3-phase stator currents.

$\Psi_a, \Psi_b, \Psi_c$  : 3-phase air-gap flux.

$V_q^s, V_d^s$  : 2-phase supply voltages.

$I_q^s, I_d^s$  : 2-phase stator currents.

$\Psi_q^s, \Psi_d^s$  : 2-phase air-gap flux.

The time varying problem can be accomplished by using the synchronously rotating reference frame model, in which all stator variables associated with fictitious winding rotating with the rotor at synchronous speed [4]. The transformation equations are:

$$F(\theta_e) = \begin{bmatrix} \cos(\theta_e) & -\sin(\theta_e) \\ \sin(\theta_e) & \cos(\theta_e) \end{bmatrix} \quad (5)$$

$$\begin{bmatrix} v_q^e \\ v_d^e \end{bmatrix} = |F(\theta_e)| \cdot \begin{bmatrix} v_q^s \\ v_d^s \end{bmatrix} \quad (6)$$

Where:

The superscript notation "s" referred to the stationary frame quantities, and the superscript notation "e" referred to the synchronously rotating reference frame quantities.

Therefore, the synchronously rotating reference frame equivalent circuits of the SG in d<sup>e</sup>-q<sup>e</sup> axis can be shown in figure (2). Equations (7 to 18) show stator and rotor circuits equations in d<sup>e</sup>-q<sup>e</sup> axis:

■ stator equations:[3, 4]

$$V_{qs}^e = -I_{qs}R_s - \omega_e \Psi_{ds} - \frac{d\Psi_{qs}}{dt} \dots (7)$$

$$V_{ds}^e = -I_{ds}R_s + \omega_e \Psi_{qs} - \frac{d\Psi_{ds}}{dt} \dots (8)$$

■ rotor equations:[3, 4]

$$0 = I_{qr}R_r - \frac{d\Psi_{qr}}{dt} \dots (9)$$

$$0 = I_{dr}R_r - \frac{d\Psi_{dr}}{dt} \dots (10)$$

$$V_f = I_f R_f + \frac{d\Psi_f}{dt} \dots (11)$$

Where:

$V_{qs}^e, V_{ds}^e$ : are the d<sup>e</sup>-q<sup>e</sup> axis stator voltages.

$I_{qs}, I_{ds}$ : are the d<sup>e</sup>-q<sup>e</sup> axis stator currents.

$\Psi_{qs}, \Psi_{ds}$ : are the d<sup>e</sup>-q<sup>e</sup> axis stator fluxes.

$R_s$  : is the stator resistance.

$I_{qr}, I_{dr}$ : are the rotor currents.

$\Psi_{qr}, \Psi_{dr}$ : are the rotor fluxes.

$R_r$ : is the rotor resistance.

$V_f$ : is the excitation voltage.

$I_f$ : is the excitation current.

$R_f$ : is the excitation resistance.

$\Psi_f$ : is the excitation flux.

Where all rotor parameters are referred to stator circuit and the mutual and self inductance of air gap (main) flux linkage are identical to  $L_{qm}$  and  $L_{dm}$  rotor to stator reduction.

$$\Psi_{qs} = L_{ls}I_{qs} + L_{qm}(I_{qs} + I_{qr}) \dots (12)$$

$$\Psi_{ds} = L_{ls}I_{ds} + L_{dm}(I_{ds} + I_{dr} + I_f) \dots (13)$$

$$\Psi_f = L_{lf}I_f + L_{dm}(I_{ds} + I_{dr} + I_f) \dots (14)$$

$$\Psi_{qr} = L_{lr}I_{qr} + L_{qm}(I_{qs} + I_{qr}) \dots (15)$$

$$\Psi_{dr} = L_{lr}I_{dr} + L_{dm}(I_{ds} + I_{dr} + I_f) \dots (16)$$

■The electromagnetic torque:[3, 4]

$$T_e = -\frac{3}{2}P_1(\Psi_{ds}I_{qs} - \Psi_{qs}I_{ds}) \dots (17)$$

■The motion equation:

$$\begin{aligned} T_{shaft} - T_e \\ = \frac{J}{P_1} \frac{d\omega_r}{dt} \end{aligned} \dots\dots (18)$$

By using equations (7 to 18) in p.u. form, with ignoring the effect of the damper winding (for simplicity), the per-phase dynamic reference frame model of a synchronous generator can be simulated as shown in figure (3). This simulation consists of dq-axis stator and rotor dynamic model in which the output stator voltage  $v_{qs}^e, v_{ds}^e$  are obtained from the voltage drop across the load resistance ( $r_L$ ):

$$v_{qs}^e = i_{qs}r_L \dots (19)$$

$$v_{ds}^e = i_{ds}r_L \dots (20)$$

The open loop output voltage performance of the S.G. without feedback, controller and AVR under no-load and full-load operating conditions in per-unit values is illustrated in figure (4).

### 3. Traditional Tuning of The PID Controller

The PID controller calculations involve three separate parameters: Proportional, Integral, and Derivative gains ( $K_P, K_I$  and  $K_D$  respectively). The proportional gain determines the reaction of the current error, the integral gain determines the reaction based on the sum of recent error, and derivative gain determines the

reaction based on the rate at which the error has been changing. Equation (21) shows the weighted sum of three actions is used to adjust the process via the final control element [5]:

$$y(t) = K_P e(t) + K_D \frac{d e(t)}{dt} + K_I \int_0^t e(t) dt \dots\dots(21)$$

Linear control systems can be easily tuned using classical tuning techniques such as Ziegler-Nichols and Cohen-Coon tuning formula. Empirical studies have found that these conventional tuning techniques result in an unsatisfactory control performance with non-linear systems. It is for this reason that control practitioners and researchers often prefer to tune most non-linear systems using trial and error method [1].

The goal of PID controller tuning process is to determine parameters that meet closed loop performance specifications, and the robust performance of the control loop over a wide range of operation conditions should also be ensured.

Practically, it is often difficult to achieve all of these desirable qualities. For example, if the PID controller is adjusted to provide better transient response to set point change, it usually results in a sluggish response under disturbance condition. On the other hand, if the control system is made robust to disturbance by choosing conservative values for the PID controller, it may result in a slow closed loop response to a set point change [1, 6]. The name plate of the used generator is illustrated in table (1).

The overall system simulation is shown in figure (5). By using trial and error method, the best result can be obtained of the PID controller parameters, to achieve a suitable output voltage performance of the non-linear synchronous generator AVR system are:

$K_p= 0.5$ ,  $K_i= 5$ , and  $K_D= 0.1$ . Which give a transient system response to the unit step input:

- Rise time= 0.6 sec.
- Maximum overshoot= 21%.
- Settling time= 3.6 sec.
- Steady state error= 0%.

The output performance of the system under no-load and full-load conditions in per-unit values can be shown in figure (6).

#### 4.1 Genetic Algorithm Optimization

Artificial intelligent techniques have come to be the most widely used tool for solving many optimization problems. Genetic Algorithm (GA) is a relatively new approach of optimum searching, becoming increasing popular in science and engineering disciplines [7].

The basic principles of GA were first proposed by Holland, it is inspired by the mechanism of natural selection where stronger individuals would likely be the winners in a competing environment [8]. In this approach, the variables are represented as genes on a chromosome. GAs features a group of candidate solutions (population) on the response surface. Through natural selection and genetic operators, mutation and crossover, chromosomes with better fitness

are found. Natural selection guarantees the recombination operator, the GA combines genes from two parent chromosomes to form two chromosomes (children) that have a high probability of having better fitness than their parents [7, 9]. Mutation allows new area of the response surface to be explored.

In this paper, a GA process is used to find the optimum tuning of the PID controller, by forming random of population of 50 real numbers double precision chromosomes is created representing the solution space for the PID controller parameters ( $K_p$ ,  $K_i$  and  $K_D$ ), which represent the genes of chromosomes. The GA proceeds to find the optimal solution through several generations, the mutation function is the adaptive feasible, and the crossover function is the scattered.

#### 4.2 Fitness Function

In PID controller design methods, the most common performance criteria are Integrated Absolute Error (IAE), the Integrated of Time weight Square Error (ITSE) and Integrated of Square Error (ISE) that can be evaluated analytically in frequency domain [2].

Each criterion has its own advantage and disadvantage. For example, disadvantage of IAE and ISE criteria is that its minimization can result in a response with relatively small overshoot but a long settling time, because the ISE performance criteria weights all errors equally independent of time. Although, the ITSE performance criterion can overcome the

disadvantage of ISE criterion. The IAE, ISE, and ITSE performance criterion formulas are as follows:

$$IAE = \int_0^t |r(t) - y(t)| dt = \int_0^\infty |e(t)| dt \quad ..(22)$$

$$ISE = \int_0^t e^2(t) dt \quad ..(23)$$

$$ITSE = \int_0^t t * e^2(t) dt \quad ..(24)$$

In this paper, the integrated of time weight square error ITSE is used for evaluating the PID controller. A set of good control parameters can yield a good step response that will result in performance criteria minimization in the time domain, this performance criterion is called Fitness Function (FF) which can be formulated as follows [2]:

$$FF = (1 - e^{-\beta})(M_p + E_{ss}) + e^{-\beta}(T_s - T_r) + ITSE \quad \dots (25)$$

Where:

$M_p$  is maximum overshoot.

$E_{ss}$  is steady state error.

$T_s$  is the settling time.

$T_r$  is the rise time.

$\beta$  is the weighting factor can set to be larger than 0.7 to reduce the overshoot and steady state error, also can be smaller than 0.7 to reduce the rise time and settling time.

The objective function of the optimization algorithm is to minimize the fitness function FF. the GA process was done by using MATLAB TOOLBOX and the flow chart of the program steps can be shown in figure (7). The obtained parameters from the GA process are;

$K_p = 1.5$ ,  $K_i = 8.21$ ,  $K_d = 1.02$ . Which give a transient system performance to the unit step input:

- Rise time= 0.33 sec.
- Maximum overshoot= 11%.

- Settling time= 2.1 sec.
- Steady state error= 0%.

The output performance of the system under no-load and full-load conditions in per-unit values can be shown in figure (8).

### 5. Particle Swarm Optimization

PSO is one of the optimization techniques first proposed by Eberhart and Colleagues [5, 6]. This method has been found to be robust in solving problems featuring non-linearity and non-differentiability, which is derived from the social-psychological theory. The technique is derived from research on swarm such as fish schooling and bird flocking. In the PSO algorithm, instead of using evolutionary operators such as mutation and crossover to manipulate algorithms, the population dynamics simulates a "bird flocks" behavior, where social sharing of information takes place and individuals can profit from the discoveries and previous experience of all the other companions during the search for food. Thus, each companion, called particle, in the population, which is called swarm, is assumed to "fly" in many direction over the search space in order to meet the demand fitness function [2, 5, 6, 10].

For n-variables optimization problem a flock of particles are put into the n-dimensional search space with randomly chosen velocities and positions knowing their best values, so far ( $P_{best}$ ) and the position in the n-dimensional space [5, 6]. The velocity of each particle, adjusted accordingly to its own flying experience and the other particles flying experience. For

example, the  $i_{th}$  particle is represented, as:

$$x_i = (x_{i,1}, x_{i,2}, \dots, \dots, x_{i,n}) \dots (26)$$

In n-dimensional space, the best previous position of the  $i_{th}$  particle is recorded as:

$$P_{best_i} = (P_{best_{i,1}}, P_{best_{i,2}}, \dots, \dots, P_{best_{i,n}}) \dots (27)$$

The modified velocity and position of each particle can be calculated using the current velocity and distance from  $(P_{best_{i,d}})$  to  $(g_{best_d})$  as shown in the following formula [2, 5, 6, 10]:

$$V_{i,m}^{(It+1)} = W * V_{i,m}^{(It)} + c1 * rand * (P_{best_{i,m}} - x_{i,m}^{(It)}) + c2 * rand * (g_{best_m} - x_{i,m}^{(It)}) \dots (28)$$

$$x_{i,m}^{(It+1)} = x_{i,m}^{(It)} + v_{i,m}^{(It+1)} \dots (29)$$

$i=1,2,\dots,n$   
 $m=1,2,\dots,d$

Where;

n = Number of particles.

d = Dimension.

It. = Iterations pointer.

$V_{i,m}^{(It)}$  = Velocity of particle no.  $i$  at iteration It.

W = Inertia weight factor.

c1,c2 = Acceleration constant.

rand = Random number between 0-1.

$x_{i,m}^{(It)}$  = Current position of particle  $i$  at iteration It.

$P_{best_i}$  = Best previous position of  $i_{th}$  particle.

$g_{best_m}$  = Best particle among all the particles in the population.

### 6. Implementing PSO Tuning for PID Controller

The implementation of particle swarm optimization in this

work is same what complex, because the performance of the system must be examined in each iteration and particles position during the optimization algorithm. Therefore, the optimization algorithm is implemented by using MATLAB m-file program and linked with the system simulation program in MATLAB SIMULINK, to check the system performance in each iteration.

In this paper, the problem is to optimize three variables which are:  $K_p$ ,  $K_i$  and  $K_d$  thus, the particles have three dimensions and particles must 'fly' in three dimensional spaces. A random of 100 particles positions is assumed and optimization algorithm of 100 iterations is used to estimate the optimal values of the PID controller parameters. The fitness function illustrated in equation (25) is used as a performance criterion.

The flow chart of the PSO algorithm program can be summarized in figure (9). The obtained parameters from the PSO tuning process of the PID controller are;

$K_p= 2.23$ ,  $K_i= 11.96$ ,  $K_d= 1.89$ . Which give a transient system performance to the unit step input:

- Rise time= 0.25 sec.
- Maximum overshoot= 9%.
- Settling time= 1.8 sec.
- Steady state error= 0%.

And output performance of the system under no-load and full-load conditions can be shown in figure (10).

### 7. ConclusionS

The system responses of different tuning methods are

illustrated in table (2). And a comparison performance between the three proposed methods in this research (trial and error, GA, and PSO methods) is shown in figure (11). The conclusion of this work can be summarized as following:

- Obviously, the PSO tuning of the PID controller is the best intelligent method which gives an excellent system performance, and the GA gives a good response with respect to the traditional trial and error method.

- In addition to the improving of system response, the PSO and GA can use a high order system in the tuning process which avoids the error of system order reduction.

- The intelligent tuning methods represent a powerful solution of non-linear system control, which reduce the complex calculations.

- Computationally optimization methods (PSO and GA) is very easy to implement and have high tolerance degree, and the computation process is very fast comparing with the conventional methods like Ziegler-Nichols or Cohen-Coon.

### 8. References

- [1] Nelendran Pillay, "A Particle Swarm Optimization Approach for Tuning of SISO PID Control Loop", MSc. Thesis, Durban University of Technology, 2008.
- [2] M. Nasri, H. Nezamabadi and M. Maghfoori, "A PSO-Based Optimum Design of PID Controller for A Linear Brushless DC Motor", World Academy of Science, Engineering and Technology, 2007.
- [3] Ion Boldea, "Synchronous Generators", Handbook, Taylor and Francis Group, 2006.
- [4] Bimal K. Bose, "Modern Power Electronic and AC Drives", Prentice Hall, 2002.
- [5] B. Nagaraj And N. Murugananth "Soft Computing-Based Optimum Design of PID Controller For A Position Control of DC Motor", Mediamira Science Publisher, Volume 51, Number 1, 2010.
- [6] B. Allaoua, B. Gasbaoui, And B. Merbarki "Setting Up PID DC Motor Speed Control Alteration Parameters Using Particle Swarm Optimization Strategy", Leonardo Electronic Journal of Practices And Technologies, Issue 14, P 19-32, 2009.
- [7] F. Martinez and M. Gastiblanco, "Increase the Boost Converter Performance Using Genetic Algorithms", Online Journal on Electronics and Electrical Engineering, Vol. 2, No, 1, 2008.
- [8] B. Allaoua, A. Laoufi, "Intelligent Controller Design for DC Motor Speed Control Based on Fuzzy Logic-Genetic Algorithms Optimization", Leonardo Journal of Science, Issue 13, P. 90-102, 2008.
- [9] C. Benachaiba, O. Abdel Khalek, and S. Dib, "Optimization of Parameters of the Unified Power Quality Conditioner Using Genetic Algorithm Method", Information



Technology and Control, ISSN 1392, Vol. 36, No. 2, 2007.  
 [10] S.M.GirirajKumar, Deepak Jayaraj and Anoop.R.Kishan, "PSO Based Tuning of a PID Controller for a High

Performance Drilling Machine", International Journal of Computer Applications (0975 - 8887), Volume 1, No. 19, 2010.

**Table (1) Generator nameplate**

Power	5 KVA
Voltage	380 V L-L
Frequency	50 Hz
Stator Resistance	1.2 Ω
Field Resistance	50 Ω
Excitation Voltage	110 V
Stator Inductance	13.6 mH
Field Inductance	33.4 mH
Rotor Inertia	0.1 kg/m <sup>2</sup>

**Table (2) System Responses of Variable Tuning Methods**

	Conven. Tuning	GA-PID Tuning	PSO-PID Tuning
M <sub>P</sub> (%)	21	11	9
T <sub>r</sub> (sec)	0.6	0.33	0.25
T <sub>s</sub> (sec)	3.6	2.1	1.8
E <sub>ss</sub> (%)	0	0	0

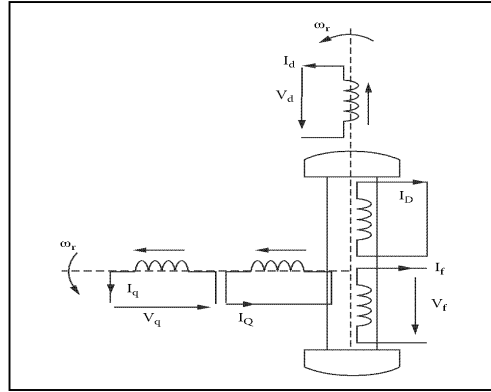

Figure (1) S.G. Windings in dq-axis

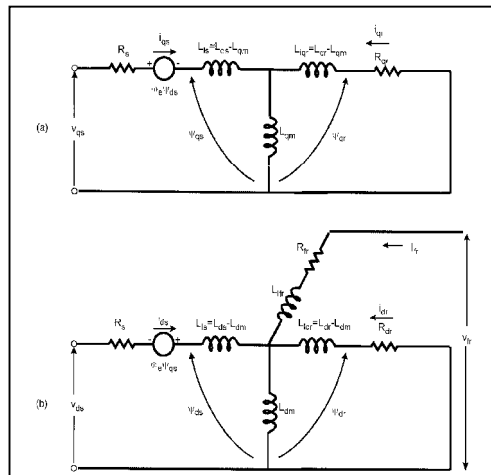

Figure (2) Stator and Rotor Equivalent Circuits in dq-axis.

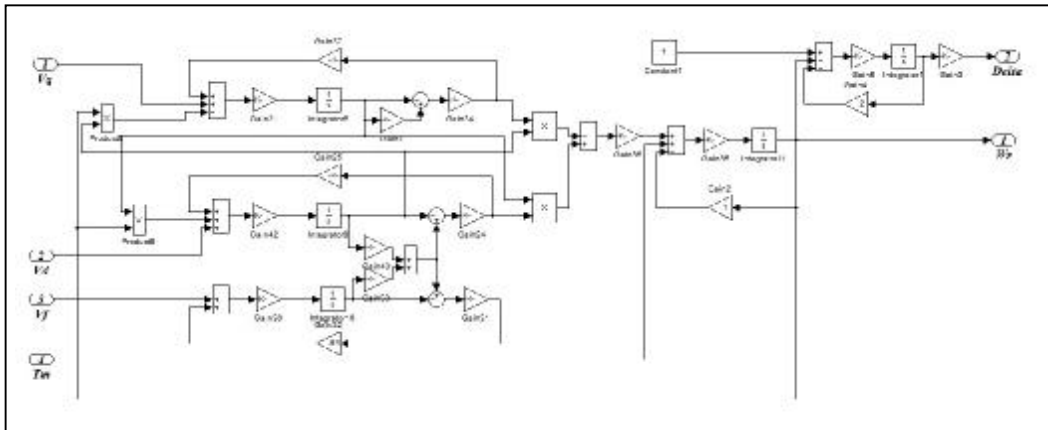

Figure (3) S.G. Simulation.

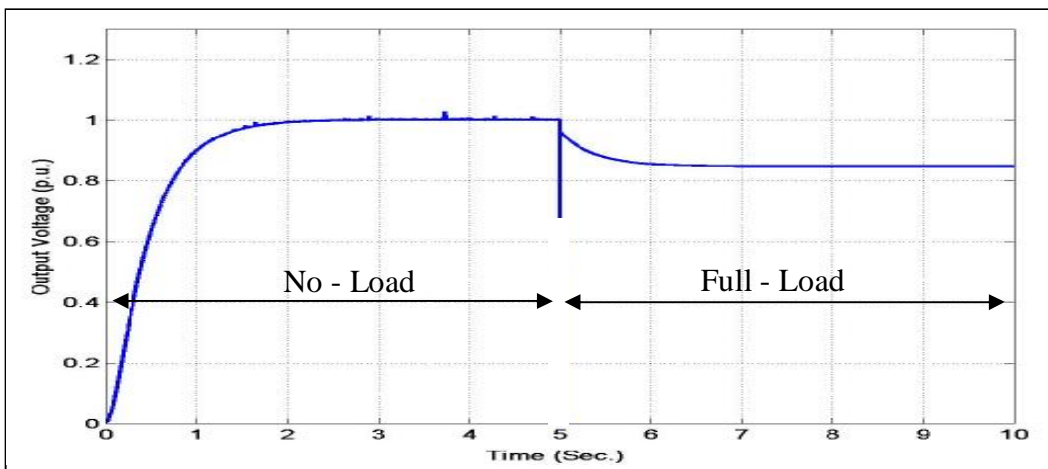

Figure (4) Open Loop Performance.

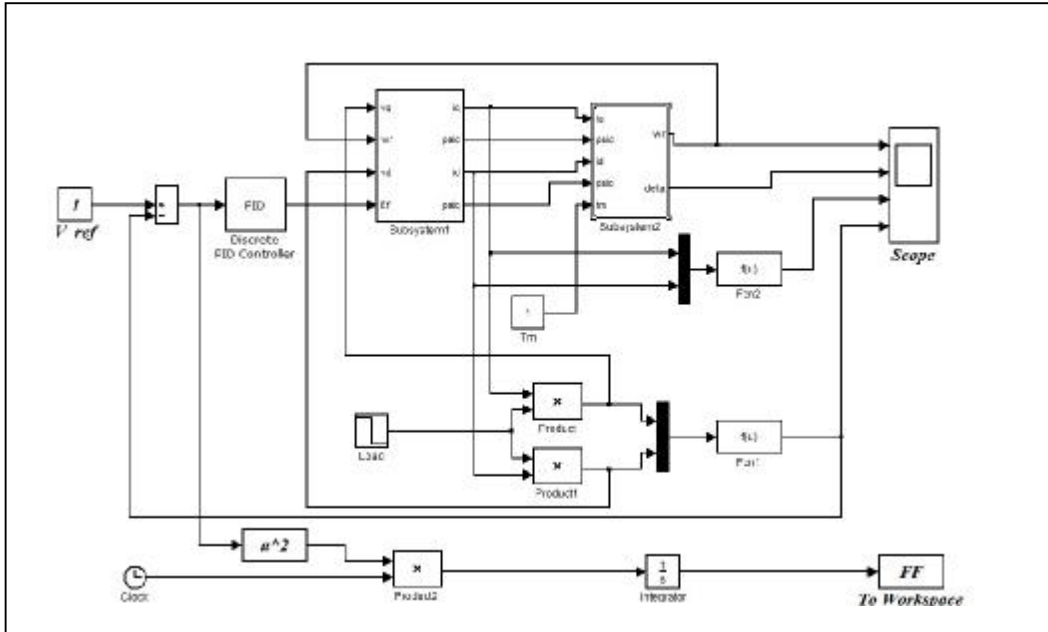

Figure (5) PID Controller of the S.G.

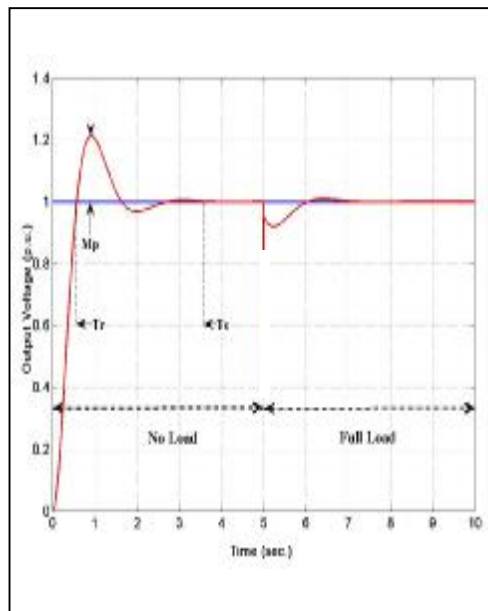

Figure (6) System Performance of Conventional PID Tuning Method.

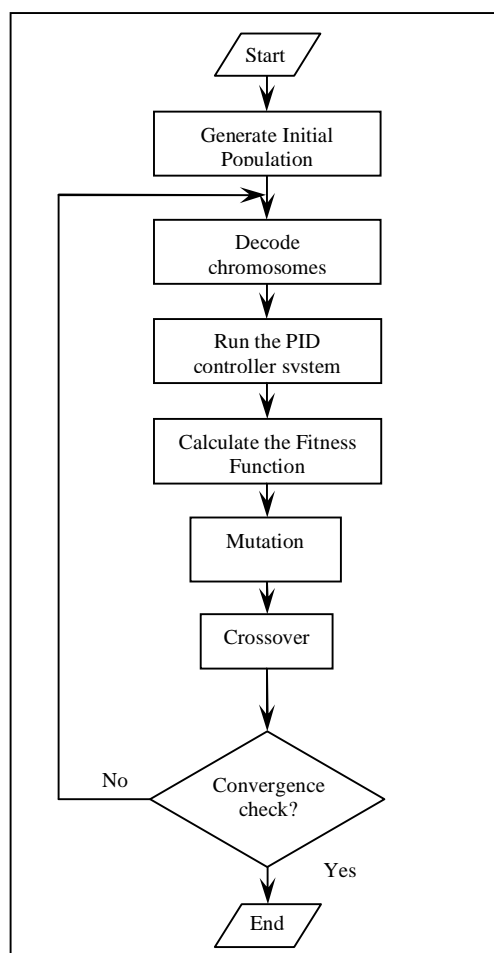

Figure (7) Flowchart of the GA.

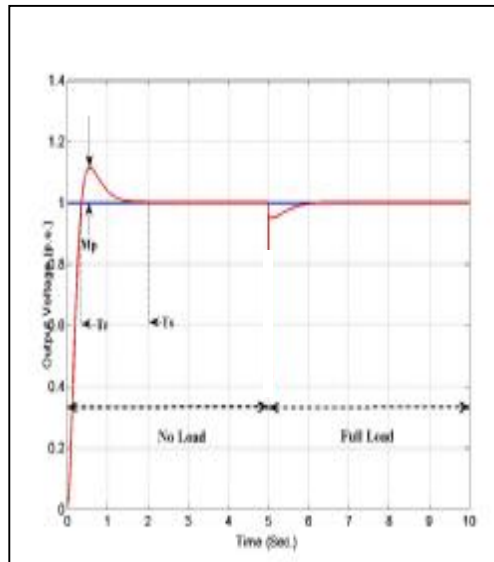

Figure (8) System Performance of GA-PID Tuning Method.

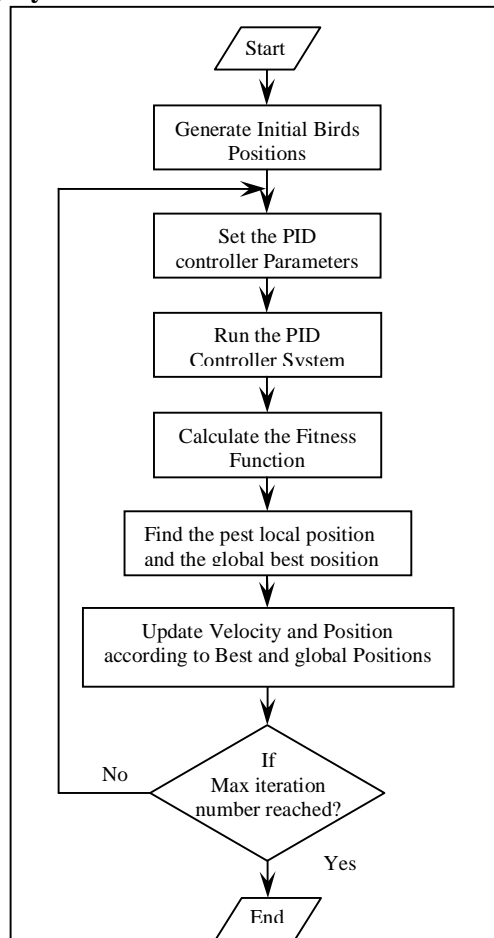

Figure (9) Flowchart of the PSO.

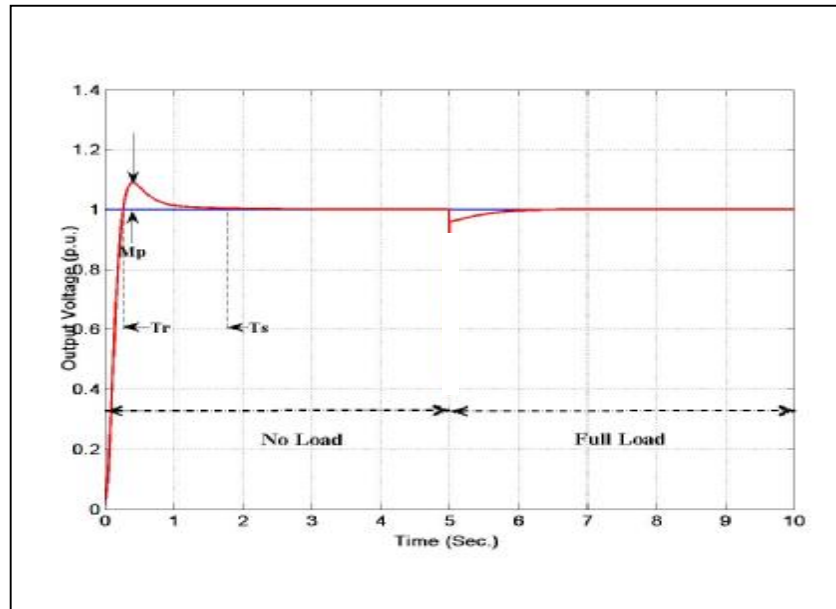

Figure (10) System Performance of PSO-PID Tuning Method.

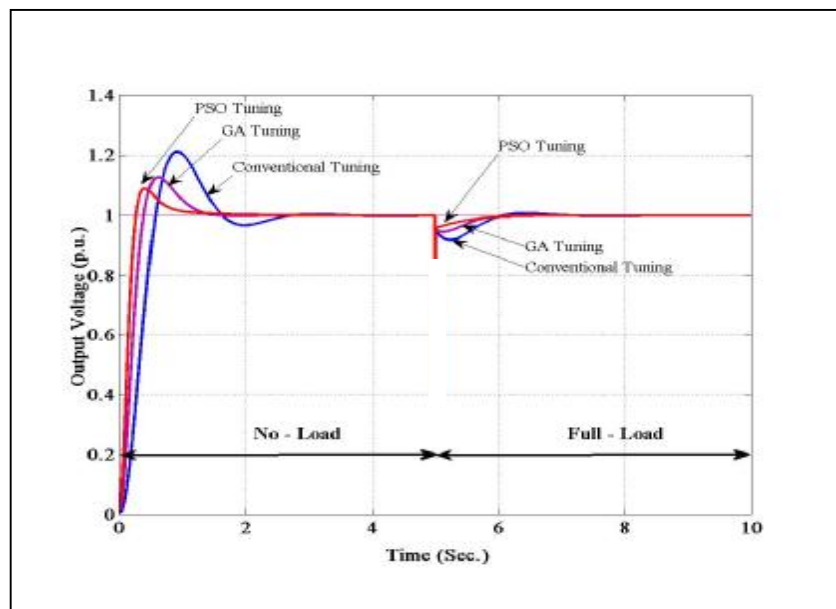

Figure (11) Comparison Performance of Different Proposed Tuning Methods.