

Simulation of a Power Transformer Differential Protective Relay

Mohammed S. Abdulraheem* & Adel Ridha Othman**

Received on:2/4/2008

Accepted on:2/7/2009

Abstract

The aim of this work is to simulate a differential relay, which ensures security for external fault, inrush, and overexcitation conditions and provides dependability for internal faults, to protect a single phase power transformer.

This work combines harmonic restraint and blocking methods with a waveshape recognition technique.

The harmonic based dual slope characteristic differential relay is modeled in MATLAB (version 7.3) functions. Two approaches are used to simulate the power transformer transients modeling to evaluate the differential relay performance for different operation conditions: The first approach has modeled the power transformer transients in MATLAB functions to simulate the inrush, overexcitation and external fault conditions, the interfacing of this model with the differential relay MATLAB functions is accomplished via the sampler model which is simulated in the environment of SIMULINK. The second approach has modeled the power transformer transients using the power system blockset to simulate the internal faults and the sinusoidal inrush current conditions, this model is set to interact with the differential relay MATLAB functions by the environment of SIMULINK.

Keywords: Transformer, Inrush, Excitation, Differential, Relaying

محاكاة مرحل حماية تفاضلي لمحولة القدرة

الخلاصة

يهدف البحث الى محاكاة مرحل تفاضلي لحماية محولة القدرة الذي يضمن الصمود أمام حالات الأعطال الخارجية ، تيار الاندفاع وتيار الاثارة التشبعي ، ويوفر وثوقية العمل للأعطال الداخلية لمحولة القدرة الاحادية الطور . هذا البحث يجمع طرق كبح وحجز التوافقيات مع تقنية تمييز الشكل الموجي .

تم صياغة نموذج المرحل التفاضلي نو الخواص الثنائية الميل والذي يعتمد اساس عمله على التوافقيات، ببرنامج MATLAB. تم استخدام طريقتين لصياغة نموذج محولة القدرة لتمثيل الحالات العابرة لغرض تقييم اداء المرحل التفاضلي لمختلف ظروف التشغيل. الطريقة الاولى تم فيها صياغة نموذج محولة القدرة ببرنامج MATLAB لتمثيل حالات التيار الاندفاعي، التيار الاثارة التشبعي والاعطال الخارجية للمحولة. وقد تم تشبيك هذا النموذج مع نموذج المرحل التفاضلي بواسطة المنمذج (Sampler) والذي تم تمثيله في بيئة SIMULINK. الطريقة الثانية تم فيها نمذجة محولة القدرة باستخدام مجموعة قوالب نظم القدرة لغرض تمثيل حالات الاعطال

* College of Electrical and Electronic Techniques/ Baghdad

** Electromechanical Engineering Department, University of Technology /Baghdad

الداخلية والتيار الاندفاعي الجيبي, هذا النموذج تم تعشيقة مع برنامج المرحل النفاضلي من خلال بيئة SIMULINK.

Nomenclature

2_{HBI} Second harmonic blocking signal.
 5_{HBI} Fifth harmonic blocking signal.
 $DCBL_1$ Direct current blocking signal.
 DCR_1 Direct current ratio.
 E_1 Enable signal.
 I_d Differential current.
 I_{OP1} Differential relay operation current.
 I_{OP1F2} Second harmonic restraint current.
 I_{OP1F5} Fifth harmonic restraint current.
 I_{OV} Relay maximum overcurrent threshold.
 $I_{P.U}$ Relay minimum pick up current threshold.
 I_{RS1} Differential relay characteristic break point.
 I_{RT1} Differential relay restraint current.
 I_{1W1} Transformer scaled primary current.
 I_{1W2} Transformer scaled secondary current.
 I_{1W1F1} Fundamental component of scaled primary current.
 I_{1W2F1} Fundamental component of scaled secondary current.
 I_{1W1F2} Second harmonic of scaled primary current.
 I_{1W2F2} Second harmonic of scaled secondary current.
 I_{1W1F5} Fifth harmonic of scaled primary current.
 I_{1W2F5} Fifth harmonic of scaled secondary current.

NEGHALF Negative half cycle d. c. content.
 POSHALF Positive half cycle d. c. content.
 SLP_1 First slope of differential relay characteristic.
 SLP_2 Second slope of differential relay characteristic
 T Restraint trip signal.
 T_1 Relay differential element 1 trip signal.
 UR_1 Unrestraint trip signal.
 spc Samples per cycle
 r Sequence of samples 0,1,2,3,.....

1. Introduction

The power system protection relay has experienced many important changes, from purely electromechanical type to the mixture of electronic and electromechanical type, then to fully static and now fully numerical relays based on microprocessors.

The most important protection scheme is the differential protection. Two trip criteria are used; the first trip criterion is based on unrestrained differential trip algorithm for heavy internal faults which will produce a very high differential current so that it is not necessary to check whether it is inrush or not. The second trip criterion is the through fault current restrained differential algorithm which also includes the waveform blocking criterion in combination criteria of second harmonic restrain-block for inrush and fifth harmonic

block for overexcitation [1]. Some researches that have been presented to develop the protection relays are outlined in the following paragraphs: A. G. Phadke, and J. S. Thorp [2]. Proposed a flux-restrained current differential relay. This relay calculates the rate of change of flux with respect to the differential current and uses it as a restraint. However, the relay uses the winding current, which is unavailable for a transformer with a delta winding. B.W. Garrett, H.W. Dommel, K.H. Engelhardt [3] developed a protection system model under transient conditions, and showed how both near-operation and near mis-operation of relays could be made visible from simulations. A. Keyhani, H. Tsai, and A. Abur [4] proposed a method to establish a multisection network model for study of high frequency transient behavior of the transformer and machine winding. The winding with equally divided sections is considered in this paper. That will make the number of sections be large if this method is used for simulating the small turn-to-turn fault of transformer. A. Giuliante, and G. Clough [5] suggested a technique based on the length of the time intervals when the differential current is close to zero. During magnetic inrush, the low current intervals are greater than one-quarter of a cycle and the relay is blocked. For internal faults, the low current intervals are less than one-quarter of a cycle and the relay operates. However, waveshape recognition techniques fail to identify overexcitation. R. C. Degeneff, M.

R. Gutierrez, and P. J. Mckenny [6] used lumped $R-L-C$ circuit to represent the transformer winding. This method requires knowledge of the details of the transformer construction to get these parameters, and these parameters are very difficult to estimate from an external testing. S. B. Wilkinson [7] Proposed a method based on waveshape recognition to distinguish faults from inrush and has applied this method in transformer relays. However, this technique do not identify transformer overexcitation conditions. M. Kezunovic, Q. Chen [8] combined EMTP and MATLAB to model protective relays. Relays were modeled in the MATLAB simulation software and connected to EMTP through an interaction buffer. Harlowe, James H., ed. [9] presented the calculations of the harmonics to restrain/block the relay on a differential basis, i.e. subtracts the low voltage harmonics from the high voltage harmonics. This calculation is necessary to separate the harmonics generated in load from the harmonics generated within the transformer. Yong-Cheol Kang, En-Shu Jin and Sung-Ho Won[10] proposed a modified-current-differential relay for transformer protection. The relay calculates the core-loss current from the induced voltage and the core-loss resistance as well as the magnetizing current from the core flux and the magnetization curve. Finally, the relay obtains the modified differential current by subtracting the core-loss and the

magnetizing currents from the conventional differential current.

2. Transformer Modeling

Accurate modeling of the power transformer is very necessary to evaluate protective relay performance and leads to the transformer protection improvement. The transformer model simulates current signals for different operating and fault conditions, these signals are applied to the differential relay to analyze its performance.

The following expressions determine the relationship between voltages, currents, and mutual flux in the transformer core [11].

$$E_1 = R_1 \cdot I_1 + L_1 \frac{\Delta I_1}{\Delta t} + N_1 \frac{\Delta f}{\Delta t} \quad \dots(1)$$

$$E_2 = R_2 \cdot I_2 + L_2 \frac{\Delta I_2}{\Delta t} + N_2 \frac{\Delta f}{\Delta t} \quad \dots(2)$$

$$\Delta f = P \cdot N_1 \cdot \Delta I_1 + P \cdot N_2 \cdot \Delta I_2 \quad \dots(3)$$

$$b = \frac{1 - \frac{1}{\sqrt{m_i}}}{B_{SAT}} \quad \dots(7)$$

$$c = \frac{1}{m_i \cdot m_0} \quad \dots(8)$$

The anhysteretic curve modeled by the Frolich equation is used to determine the permeability values for the different magnetic flux conditions presented in transformer operation.

Figure 1 shows the anhysteretic B-H curve of ferromagnetic material calculated from the transformer modeling algorithm according to Frolich equation (equation 6).

All terms have fixed values except the permeance P. The following expression determines the permeance of a given transformer core:

$$P = \frac{m \cdot A}{l} \quad \dots(4)$$

The ratio of the incremental value of the flux density to the incremental value of the magnetic field intensity determines the permeability μ.

$$m = \frac{\Delta B}{\Delta H} \quad \dots(5)$$

In this case, three differential equations must be solved. These equations can be solved with the fourth-order Runge-Kutta numerical method.

The empirical Frolich Equation models the S shape of the anhysteretic B-H curve.

The following equations determine the empirical b and c constants

$$B = \frac{H}{c + b \cdot |H|}$$

Whereas figure 2 shows the variation of permeability μ with magnetic field intensity H calculated from the transformer modeling algorithm according to Frolich equation (equation 6).

2.1 Transformer Modeling in SIMULINK

Figure 3 shows a schematic diagram of a SIMULINK model, which is used to

simulate the transformer normal operation condition (no fault situation), internal faults conditions and the transformer energization with sinusoidal inrush current condition to evaluate the differential relay performance

3. Differential Relay Modeling

Figure 4 shows a schematic diagram of one of the percentage differential elements (Element 1 of three phase differential relay) with 2nd harmonic restraint-blocking, 5th harmonic blocking, and D.C. blocking, this diagram is simulated by MATLAB functions. Input to the differential element are the filtered, scaled, and compensated sets of samples corresponding to the fundamental component, second and fifth harmonics of the transformer primary and secondary currents.

The magnitude of the sum of the fundamental component of the primary and secondary currents (I_{1WF1} and I_{1WF2} respectively) forms the operating current I_{OP1} .

The scaled magnitude of the difference of the fundamental component currents forms the restraint current I_{RT1} .

Comparator 1 and switch S_1 select the slope according to the value of the restraint current to provide a dual-slope percentage characteristic to calculate the restraint current $I_{RT1} f(slp)$.

The scaled magnitude of the sum of the second harmonic of the transformer primary and secondary currents (I_{2WF1} and I_{2WF2} respectively) represent the second harmonic restraint current I_{OP1F2} the scaling factor is PCT_2

The scaled magnitude of the sum of the fifth harmonic of the transformer primary and secondary currents (I_{5WF1} and I_{5WF2} respectively) represents the fifth harmonic restraint current I_{OP1F5} .

Comparator 4 compares the operating current I_{OP1} with the sum of the fundamental and second harmonic restraint currents I_{R1} , to generate R_1 signal, the comparator asserts for fulfillment of equation 9.

$$I_{OP1} > SLP * I_{RT1} + I_{OP1F2} \quad \dots(9)$$

Comparator 3 enables the relay by E_1 signal if the operating current I_{OP1} is greater than a threshold value I_{PU} , Comparators 5 and 6 compare the operating current to the second- and fifth-harmonic restraint currents to generate the second harmonic 2_{HB1} and fifth harmonic 5_{HB1} blocking signals according to equations 10 and 11

$$I_{OP1} < I_{OP1F2} \quad \dots\dots (10)$$

$$I_{OP1} < I_{OP1F5} \quad \dots\dots(11)$$

The differential relay includes an unrestrained instantaneous differential overcurrent trip function by Comparator 2 which compares the operating current I_{OP1} with a threshold value I_{OV} to provide the unrestrained differential overcurrent trip signal UR_1 .

Comparator 7 compares the d.c. ratio DCR_1 with a 0.1 threshold to generate the relay d.c. blocking signal $DCBL_1$.

The inputs to the AND gate are: E_1 , R_1 , 2_{HB1} , 5_{HB1} , and $DCBL_1$.

The output of the AND gate is the restraint trip signal T .

The restraint trip signal T is ORed with the unrestraint trip signal UR_1 to generate the final trip signal T_1 .

The settings of the differential relay which is simulated in MATLAB functions are as follows:

The relay minimum pick up current threshold $I_{PU} = 0.3 p.u.$

The relay maximum overcurrent threshold $I_{OV} = 30 p.u.$

First slope of differential relay characteristic $SLP_1 = 25\%$

Second slope of differential relay characteristic $SLP_2 = 60\%$

Differential relay dual slope characteristic break point $I_{RS1} = 3 p.u$

Second harmonic scaling factor $PCT_2 = 1/0.16$

Fifth harmonic scaling factor $PCT_5 = 1/0.3$

3.1 Digital Filter Modeling

A 16 sample/cycle full cycle window is used in this work, while extracting the wanted components; the filter rejects all other harmonics including the decaying exponential. The filter in equation form appears as follows:

The filter cosine coefficients are:-

$$CFC_n = \cos\left[\frac{2\pi n}{N}\right] \quad \dots (12)$$

The filter sine coefficients

$$SFC_n = \sin\left[\frac{2\pi n}{N}\right] \quad \dots(13)$$

The real part of the filter output is:-

$$filtc = \frac{2}{sp} \sum_{r+sp \leq n}^{N-1} I_{r+sp \leq n} \cdot CFC_n \quad \dots(14)$$

The imaginary part of the filter output is:-

$$fils = \frac{2}{sp} \sum_{r+sp \leq n}^{N-1} I_{r+sp \leq n} \cdot SFC_n \quad \dots (15)$$

The output filter phasor magnitude is:-

$$\sqrt{(filtc)^2 + (fils)^2} \quad \dots(16)$$

The phase is:-

$$f = \arctan \frac{fils}{filtc} \quad \dots (17)$$

In equation 14 and equation 15, any value of r indicates that 16 samples of the current have been stored. The index n ranges from 0 to 15 to apply the coefficients and sum the samples to produce the output [12].

4. The sampler

Figure 5 shows the sampler used to interface MATLAB transformer

modeling functions with MATLAB differential relay functions.

The transformer primary and secondary currents (I_{Iw1} and I_{Iw2} , respectively) obtained from the MATLAB transformer modeling functions must be sampled before they can be used by the MATLAB relay functions.

The anti aliasing analog low – pass filter is a second order butterworth of 400 Hz cutoff frequency.

The zero order hold sampling time is 0.00125 second corresponding to a sampling rate of 16 samples per cycle.

The quantization interval is set to 1/4096

5. Cases Simulation in MATLAB

(a) Energization Condition

The transformer is energized from the high side with a rated voltage of 230 volts, the transformer primary and secondary currents are shown in figure 6a and figure 6b, respectively.

The primary inrush current I_{Iw1} initial value is about 30 p.u times the rated value with a decaying dc offset.

The secondary current I_{Iw2} is a rated current of magnitude 1 p.u.

As shown in figure 6c the differential relay enters the operating zone where I_{OP1} is greater than I_{RT1} but lesser than I_{OP1F2} , so I_{OP1} is lesser than I_{R1} and thus the trip signal T_1 is not activated as shown in figure 6d, and the relay displays good security against the inrush current.

(b) Overexcitation Condition

This case is simulated by applying 150% overvoltage to the high side of the transformer model with full load, figure 7a and figure 7b show the primary and secondary currents respectively.

The peak value of the excitation current shown in figure 7c is approximately 10 p.u. of the rated current. Figure 7d shows that I_{OP1} is

greater than I_{RI} , so the relay enters its operating zone. However, the blocking signal 5_{HBI} is issued due to I_{OPIF5} is greater than I_{OP1} and thus the differential relay does not declare a trip as shown in figure 7e, T_I is not activated.

(c) External Fault Condition

An external fault (phase-to-ground) is simulated at the low side of the transformer model. Figure 8a and figure 8b show high and low side currents respectively. From figure 8c, I_{OPIF2} is greater than I_{OP1} and then I_{RI} is greater than I_{OP1} , so the restraint R_I and the blocking 2_{HBI} signals are produced. The differential relay does not declare a trip condition as shown in figure 8d and T_I is not activated.

(d) Sinusoidal Inrush Condition

The transformer is energized with rated load with sinusoidal inrush current with decaying d.c. offset. Figure 9a show the transformer primary current. Figure 9b shows the differential relay current signals, it is clear that I_{OP1} is greater than restraint and blocking current signals. For this situation the relay must declare a trip, but the blocking signal $DCBL_I$ has an objection on this declaration and the relay trip signal T_I is not activated as shown in figure 9c.

(e) Internal Fault Condition

This case is simulated by Short circuiting 25% of the transformer secondary turns to ground. Short circuit incidence is during transformer normal operation with rated load. Figure 10a, figure 10b and figure 10c show the current signals. Figure 10d shows the trip signal T_I which is activated by the relay. Trip time is 16.3 msec. after fault incidence.

6. Differential Relay Sensitivity

The differential relay sensitivity to detect the transformer internal faults depends on its security, i.e. increasing the security of the relay decreasing the sensitivity and vice versa. Increasing the second harmonic scaling factor PCT_2 increasing the relay security against inrush currents but this causes increasing the minimum percentage of the transformer winding turns which is protected by the relay. Table 1 shows variation of relay sensitivity with PCT_2 .

7. Differential Relay Operation Speed

The differential relay speed of operation (trip time) to activate a trip signal after an internal fault incidence depends on its security, i.e. increasing the security of the relay increasing the trip time and vice versa. Increasing the second harmonic scaling factor PCT_2 increasing the relay security against inrush currents but this causes decreasing of its speed to detect and isolate the faulted transformer.

Table 2 shows variation of relay trip time with PCT_2 .

8. Discussion

The model of the percentage restraint differential relay consisted in setting the values of the slopes of the differential characteristic (SLP_1 and SLP_2) to achieve a correct operation of the differential relay during normal operation and in the event of a fault. Figure 11a shows zooming of the differential relay currents during normal operation and figure 11b shows zooming of the differential relay currents after occurrence of a phase to ground fault ring at time of $t = 0.1$ seconds at 25% of the transformer winding turns. Equations 18 and 19 were employed to

calculate the operating and restraint currents, respectively.

$$I_{OP1} = |I_{IW1F1} + I_{IW2F1}| \quad (18)$$

$$I_{RT1} = 0.5 |I_{IW1F1} - I_{IW2F1}| \quad (19)$$

During normal operation, the operating current I_{OP1} must be smaller than the restraining current I_{RT1} and consequently smaller than total restraining current I_{R1} , and in a fault, the operating current must be larger than the restraining currents. In normal operation shown in figure 11a, it is observed that these differential currents fulfilled the requirements of a correct operation. After the fault inception, as shown in figure 11b, it is only in the transitory part that the relay currents did not fulfill the requirements of a correct operation.

The harmonic-restrained differential relay employs the second harmonic of the operating current to overcome the problems in the protection of power transformers due to the presence of inrush current. Equation 9, suggests that the second harmonic restraint current I_{OP1F2} must be added to the restraint current I_{RT1} to constitute the total restraint current I_{R1} , this current is assured to be larger than the operating current during the time of the inrush current effect.

However, the previous action had a temporary negative effect in the operation of the differential relay after fault inception. Figure 11b shows the zooming of the differential currents just after the fault inception, It is observed that the second harmonic of the operating current had pick value from the time of the fault inception $t = 0.1$ seconds up to $t = 0.1163$ seconds where the relay initiate a trip signal. Although this pick value causes a delaying in the identification of the fault condition, the differential relay showed correct operation for the simulated fault.

9. conclusions

(a) The relay model provides a valuable insight into the internal behaviour of a relay in a wide range of field events and application.

(b) Harmonic restraint or blocking increases differential relay security, but could delay relay operation for internal faults combined with inrush current.

(c) Harmonic blocking and harmonic restraint techniques may not be adequate to prevent differential relay operation for unique cases with very low harmonic content in the operating current. Some form of waveshape recognition may be required to ensure security for these unique conditions without sacrificing fast and dependable operation when energizing a faulted transformer.

10. References

- [1] J. Wang, Z. Gajic and S. Holst, "The Multifunctional Numerical Transformer Protection and Control System with Adaptive and Flexible Features", ABB Automation Products AB, Sweden, 2001.
- [2] A. G. Phadke, and J. S. Thorp, "A New Computer-Based Flux-Restrained Current-Differential Relay for Power Transformer Protection," IEEE Trans. on PAS, Vol. 102, No. 11, pp. 3624-3629, Nov. 1983.
- [3] B. W. Garrett, H. W. Dommel, K. H. Engelhardt, "Digital Simulation of Protection Systems Under Transient Conditions," Proceedings of the Ninth Power Systems Computation Conference, Cascais, Portugal, September 1987, Butterworths (London), pp. 291-297.
- [4] A. A. Keyhani, H. Tsai, and Abur, "Maximum likelihood estimation of

- high frequency machine and transformer winding parameters,” IEEE Trans. on Power Delivery, vol. 5, No. 1, pp. 212–219, Jan. 1990.
- [5] A. Giuliante, and G. Clough, “Advances in the Design of Differential Protection for Power Transformers”, 1991 Georgia Tech. Protective Relaying Conference, Atlanta, GA, pp. 1-12, May 13, 1991.
- [6] R. C. Degeneff, M. R. Gutierrez, and P. J. Mckenny, “A Method for Constructing Reduced Order Transformer Models for System Studies from Detailed Lumped Parameter Models,” IEEE Trans. on Power Delivery, Vol. 7, No. 2, pp. 649–655, Apr. 1992.
- [7] S. B. Wilkinson, “Transformer Differential Relay”, U.S. Patent No 5627712, May 6, 1997.
- [8] M. Kezunovic, Q. Chen, “A Novel Approach for Interactive Protection System Simulation,” IEEE Trans. on Power Delivery, Vol. 12, No.2, April 1997, pp. 668-674.
- [9] Harlowe, James H., ed., “Electric Power Transformer Engineering”, Boca Raton, FL: CRC Press, 2004.
- [10] Yong-Cheol Kang, En-Shu Jin and Sung-Ho Won, “Modified Current Differential Relay for Transformer Protection”, KIEE International Transaction on Power Engineering, Vol. 5-A No. 1, PP. 1~8, 2005.
- [11] Stanley E. Zocholl, Armando Guzman and Daqing Hou, Schweitzer Engineering Laboratories, Inc., Pullman, Washington, “Transformer Modeling as Applied to Differential Protection”, 22nd Annual Western Protective Relay Conference, Spokane, WA, October 24-26, 1995.
- [12] Stanley E. Zocholl and Gabriel Bemouyal, Schweitzer Engineering Laboratories, Inc., Pullman, WA, USA, “How Microprocessor Relays Respond to Harmonics, Saturation and other Wave Distort

Table (1) Variation of Relay Sensitivity with PCT_2

PCT_2	Minimum Percentage % of protected winding turns
1/0.16	18
1/0.2	14
1/0.24	11
1/0.28	10
1/0.32	9
1/0.36	7

Table(2) Variation of Relay Trip Time with PCT_2

PCT_2	Trip Time (msec)
1/0.05	18.8
1/0.16	16.2
1/0.2	15.8
1/0.24	15.4
1/0.28	15
1/0.32	14.3
1/0.36	13.8

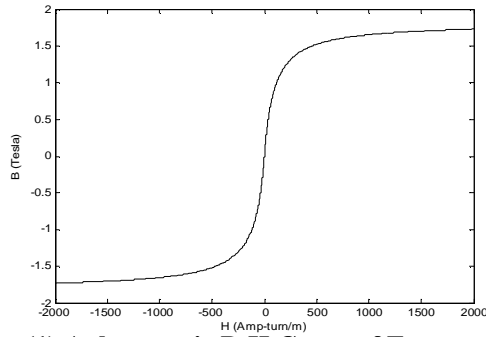

Figure (1) Anhyseritic B-H Curve of Ferromagnetic Materials Calculated by the Transformer Modeling Algorithm.

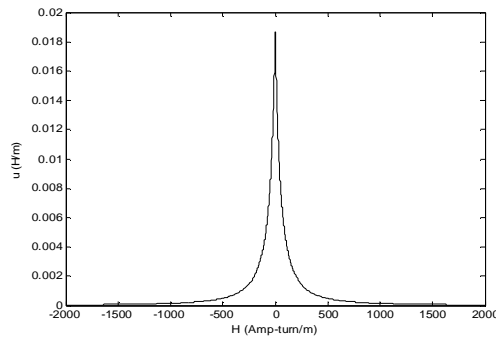

Figure (2) Permeability μ (H/m) versus Field Intensity H (Amp-turn/m) Calculated by the Transformer Modeling Algorithm.

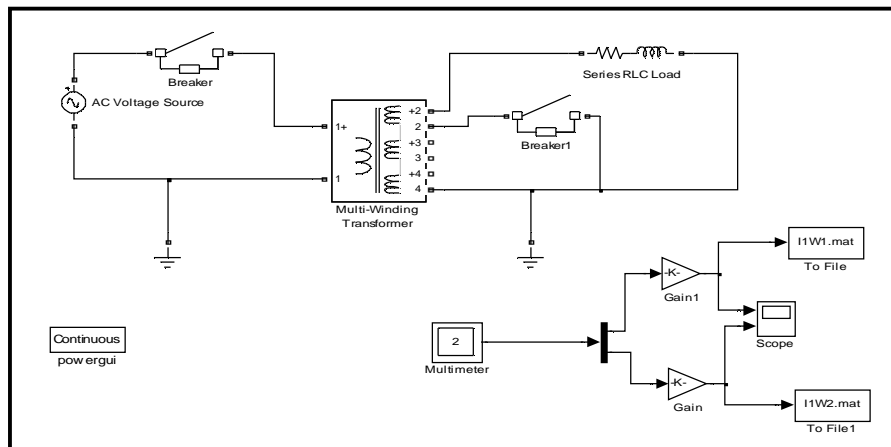

Figure (3) Schematic Diagram of Transformer Modeling in SIMULINK.

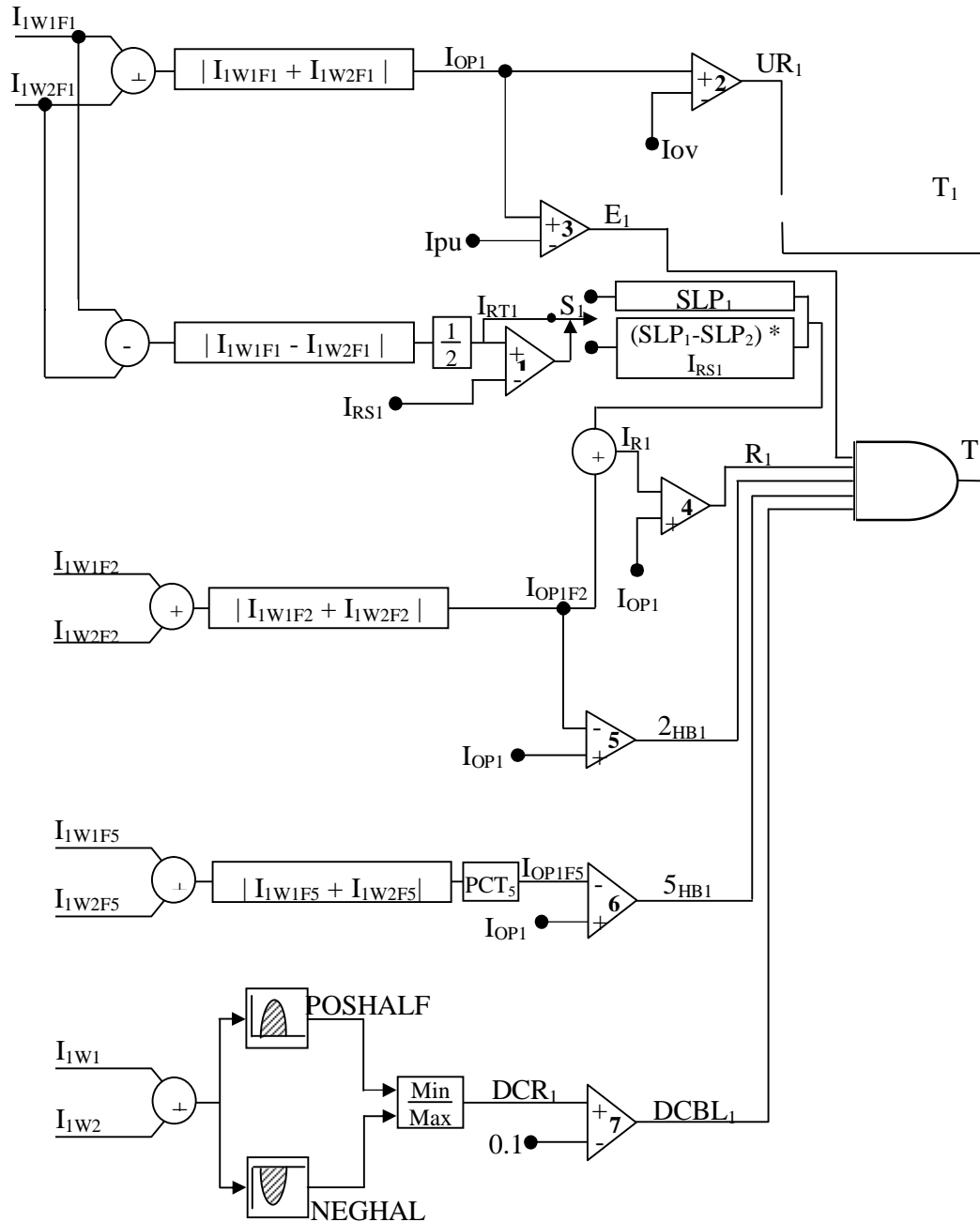

Figure (4) Schematic Diagram of Differential Relay Modeling in MATLAB

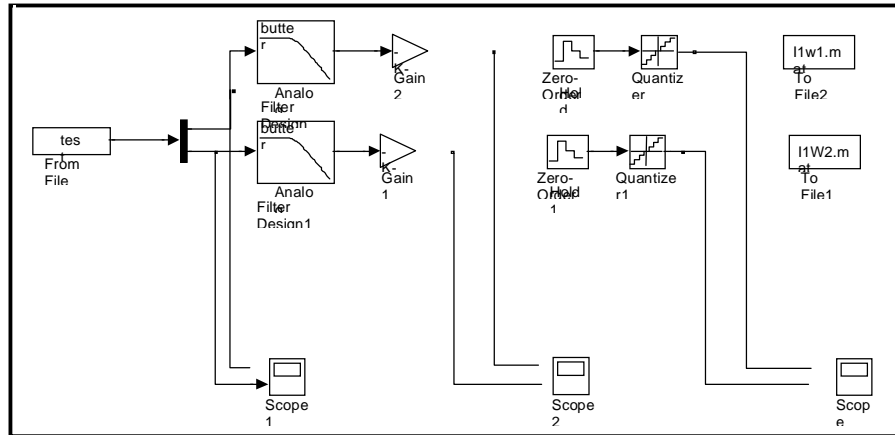

Figure (5) Sampler Schematic Diagram

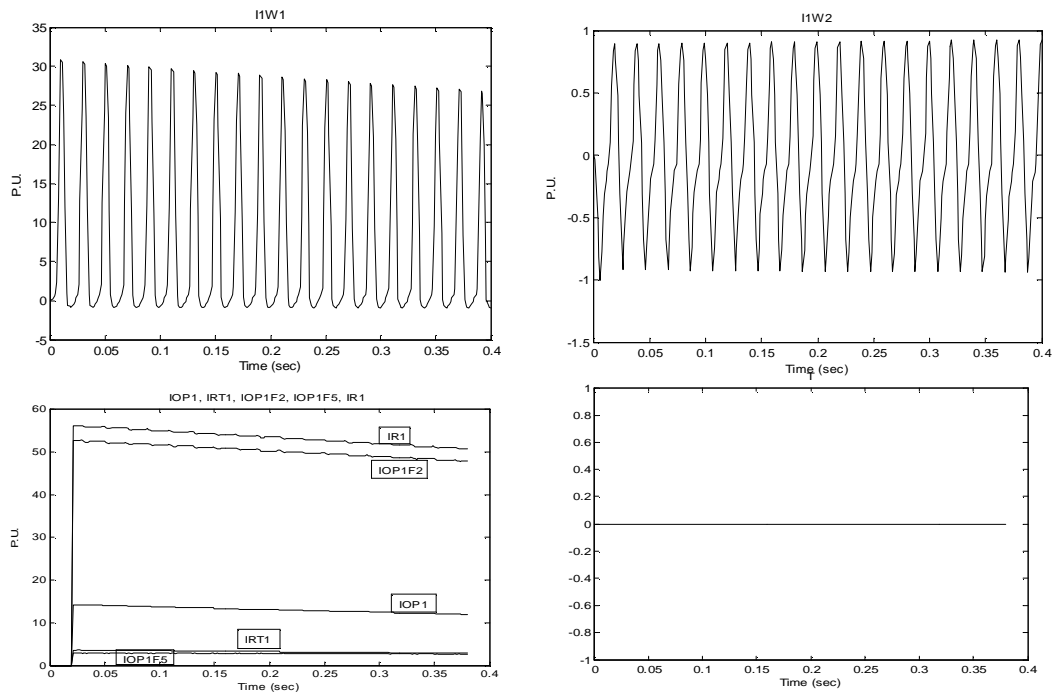

Figure (6) [Energization Condition: (a. Primary Current, b. Secondary Current. c. Relay Current Signals, d. Relay Trip Signal.)]

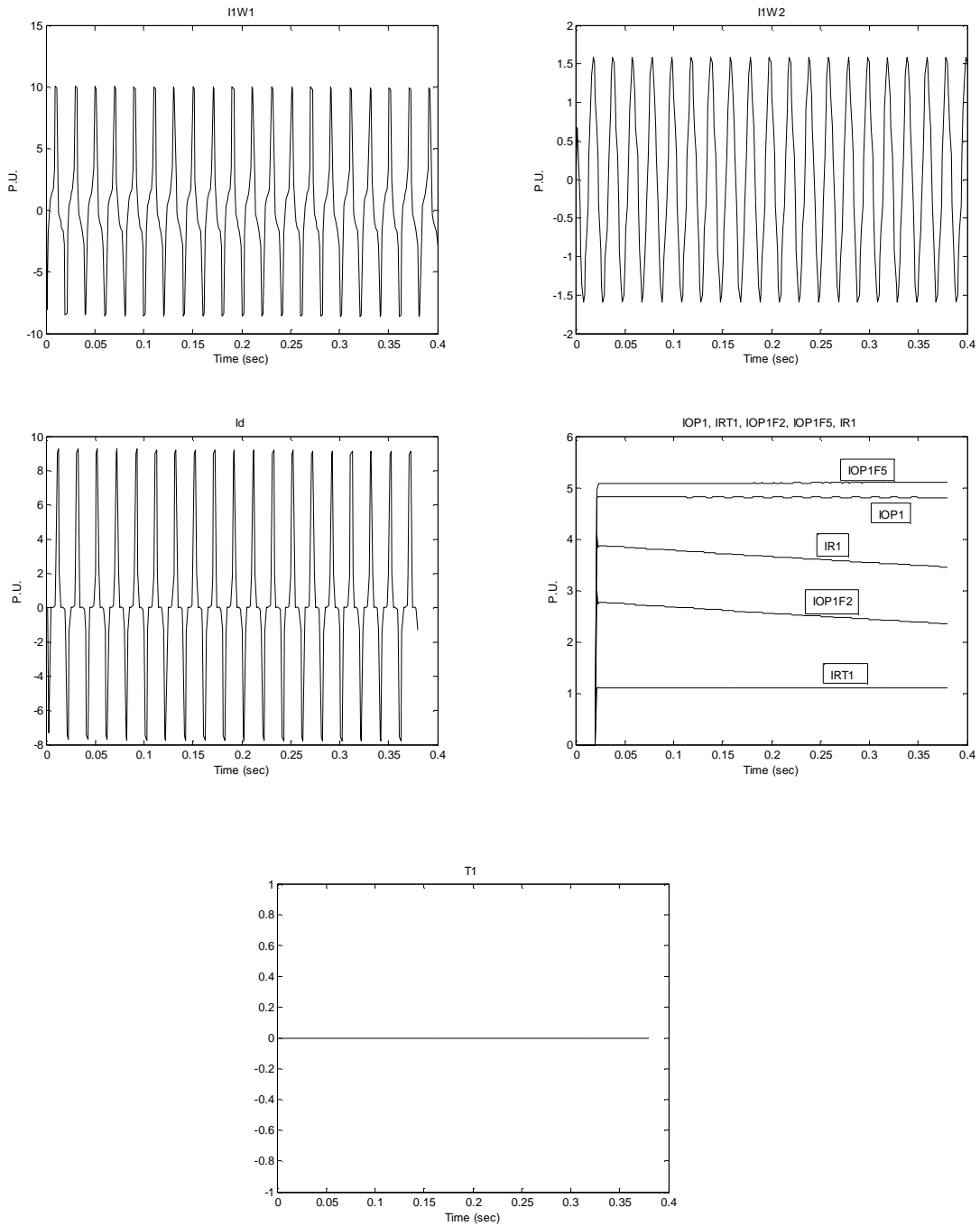

Figure (7) [Overexcitation Condition: (a. Primary Current, b. Secondary Current, c. Differential Current, d. Relay Current signals, e. Relay Trip Signal.)]

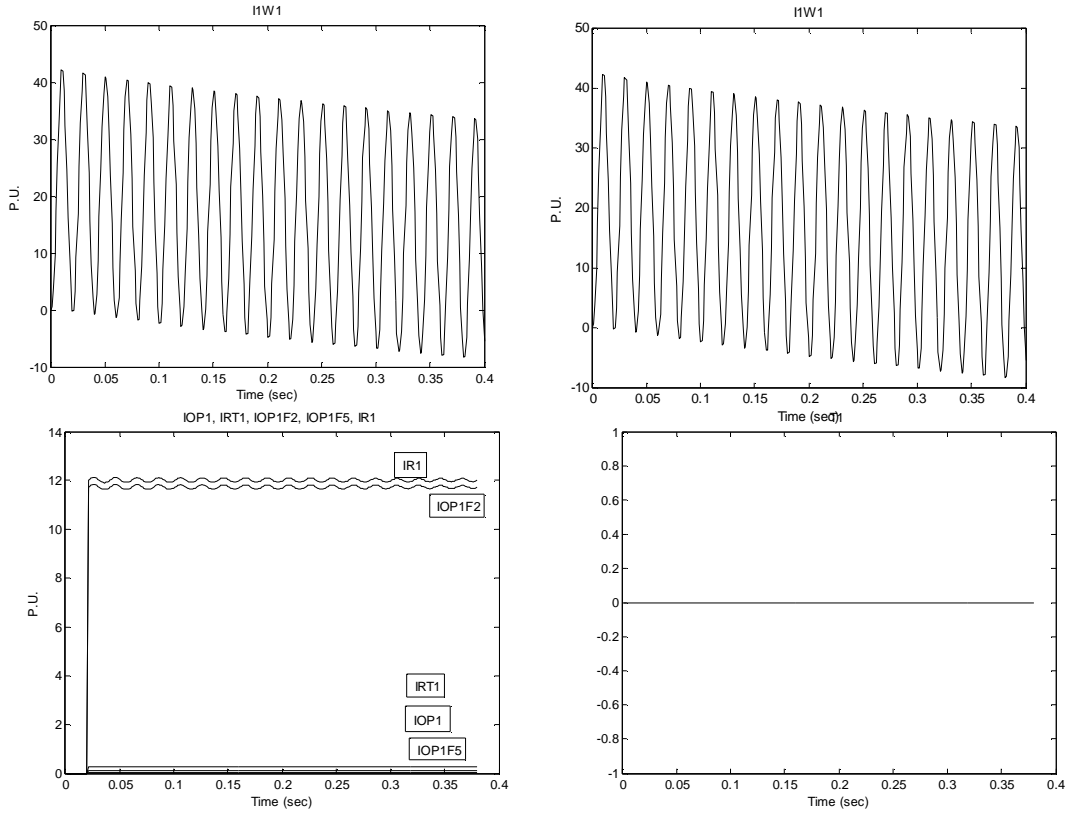
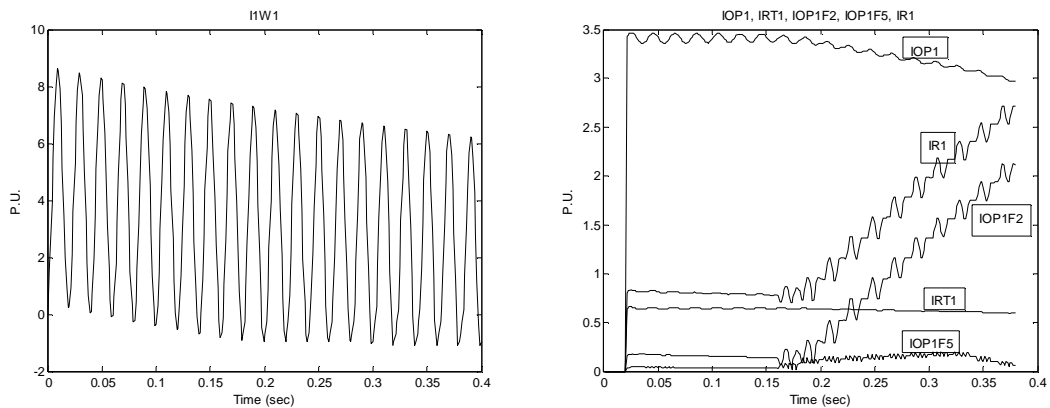

Figure (8) [External Fault Condition: (a. Primary Current, b. Secondary Current, c. Relay Current signals, d. Relay Trip Signal.)]



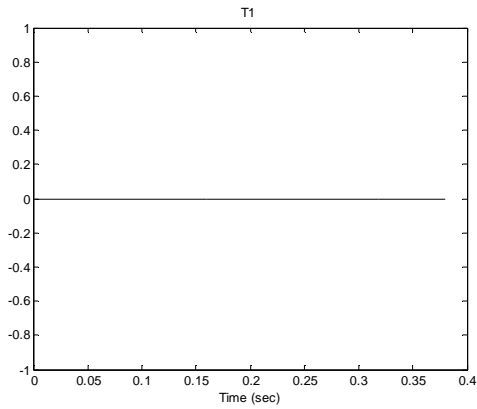

Figure (9) [Sinusoidal Inrush Condition: (a. Primary Current, b. Relay Current signals, c. Relay Trip Signal.)]

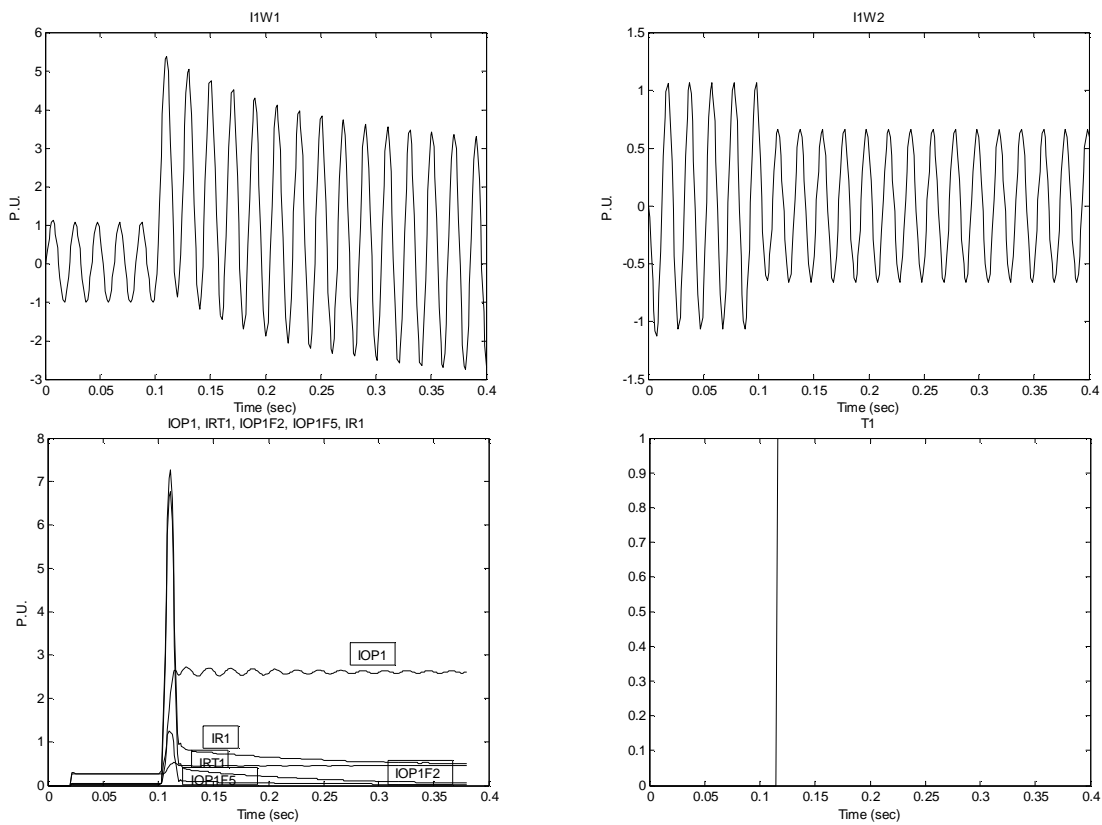

Figure (10) [Internal Fault Condition: (a. Primary Current, b. Secondary Current, c. Relay Current Signals, d. Relay Trip Signal.)]

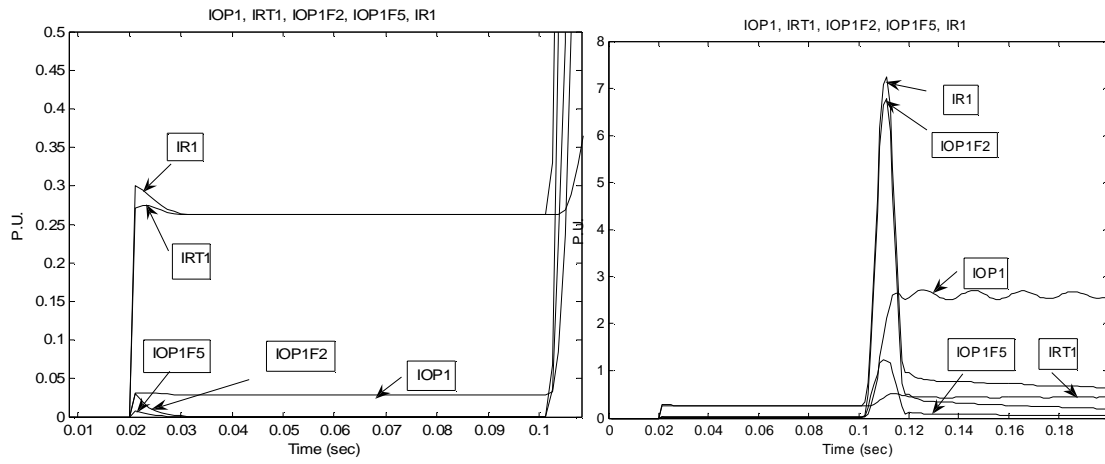

Figure (11) [a.Zooming of the Relay Currents During Normal Operation,b.Zooming of the Relay Currents after Fault Inception.]