

Interaction of Curves Proposed for Design and Analysis of Hollow Reinforced Concrete Columns

Dr. Alaa K. Abdal Karim

Building and Construction Engineering Department, University of Technology/Baghdad
Email:sadig@yahoo.com

Dr. BassmanR. Muhammad

Building and Construction Engineering Department, University of Technology/ Baghdad

Dr. Ali S. Rishak

Building and Construction Engineering Department, University of Technology/ Baghdad

Received on:8/5/2012 & Accepted on:6/12/2012

ABSTRACT

This Study is aimed to present a simplified approach enable to construction of a new design charts for hollow section reinforced concrete columns subjected to an axial compressive load and uniaxial bending. These design charts can be used directly in the analysis and design of hollow section columns. These charts can be used in design to determine the required amount of steel reinforcing in addition to the required column dimensions, while in the analysis by using these charts; the column load capacity can be estimated.

Two design examples are given to explain the use of the new design charts. It has been shown by these examples that the new proposed charts are very simple to use in structural design applications.

الأعمدة الخرسانية المسلحة المجوفة المقطع والمعرضة لحمل محوري وعزم انحناء أحادي المحور

الخلاصة

تهدف هذه الدراسة إلى تقديم نظرة مبسطة من خلال إنشاء منحنيات تصميم جديدة للأعمدة الخرسانية المجوفة المقطع والمعرضة لحمل انضغاط محوري وعزم أحادي المحور. هذه المنحنيات يمكن أن تُستعمل مباشرة في تحليل وتصميم الأعمدة الخرسانية المجوفة المقطع. منحنيات التصميم يمكن أن تُستعمل في التصميم لتحديد الكمية اللازمة لحديد التسليح بالإضافة إلى تحديد أبعاد العمود المطلوبة، بينما في التحليل. وباستخدام هذه المنحنيات يمكن تخمين قابلية حمل العمود.

ولغرض توضيح وشرح عملية استخدام منحنيات التصميم المقترحة في التصميم والتحليل تم وضع مثالين تصميمية. وقد تبين في هذه الأمثلة بأن منحنيات التصميم المقترحة تمتاز ببساطتها في تطبيقات التصميم الإنشائية.

INTRODUCTION

Arbitrarily shaped reinforced concrete members subjected to uniaxial or biaxial bending with axial compression are frequently used in multistory tall buildings and bridge piers. In the last decades, some methods have been presented for the ultimate strength analysis of various concrete sections, such as L, T, I and C shaped, under uniaxial or biaxial bending with axial compression⁽¹⁻⁵⁾. These methods compute the ultimate flexural capacity of section. For design purposes it has been require trial and error procedures.

The present research also aims to obtain direct relationships between the compression load and the uniaxial bending capacities which can be used as ready design charts for short hollow shaped columns.

RESEARCH SIGNIFICANCE

This research deals with reinforced concrete *hollow shaped* cross sections commonly used as columns and enclosure of the elevator shafts. The principal aim of this work is to present a method for analyzing tied short columns under the combined action of axial compressive load and uniaxial bending that is simple in concept and can be beneficially used in providing easy way to deal with charts for the design of such columns.

DESCRIPTION OF THE PROCEDURE

For columns subjected to uniaxial bending, the neutral axis (NA) always remains parallel to the axis about which the moment is being applied. Since the position of the neutral axis depends on the value of the eccentricity (e), therefore the variation of the neutral axis position may in general leads to the two possible cases of compression zone shown in Figure (1). From the point of view of economy, and also for reducing the self-weight of the column resist a high value of a moment, this research is aimed to study the behavior of this type of columns.

ESTIMATING CONCRETE COMPRESSION AND STEEL FORCES

Depending on an equivalent rectangular compression block for concrete, defined by ACI-318M⁽³⁾, the area of concrete on the tension side of the neutral axis in a rectangular column cross section does not provide any appreciable moment and axial of resistance hence is neglected. Figures. (2 and 3).

Concrete Compression Force.

Case	Compression Zone	C _c
I	$a \leq \frac{H_x - h_x}{2}$	$f_c'' [H_y \cdot a]$
II	$\frac{H_x - h_x}{2} < a \leq H_x - h_x$	$f_c'' \left[\frac{H_x - h_x}{2} H_y + \left(a - \frac{H_x - h_x}{2} \right) (H_y - h_y) \right]$
III	$H_x - h_x < a \leq H_x$	$f_c'' [(H_x \cdot H_y - h_x \cdot h_y) + H_y (a - H_x)]$

In which;

- $f'_c =$ the specified cylinder compressive strength of concrete;
- $f''_c = \alpha_1 f'_c = 0.85 f'_c$;
- $H_x =$ larger overall column dimension;
- $H_y =$ shorter overall column dimension;
- $h_x =$ hollow dimension coincide with H_x ;
- $h_y =$ hollow dimension coincide with H_y ; and
- $a = \beta_1 c$ depth of equivalent rectangular stress block, where c is the distance from extreme compression fiber to neutral axis and β_1 is the factor relating depth of equivalent rectangular compressive stress block to neutral axis depth.

The steel forces can be estimated as:

$$F_{si} = A_{si} \left[\frac{c - d_i}{c} E_s \cdot \epsilon_c - f_c^n \right]$$

According to the ACI 318M, $\epsilon_c = 0.003$, and E_s is the modulus of elasticity of the steel reinforcement equals 200000 MPa, d_i is the distance of the specified steel layer from the extreme fiber of the concrete in compression and A_{si} is the total area of the steel layer. Noting that the steel can be idealized as elastic perfectly plastic material with maximum yield value of the steel stress (f_y).

$$P_n = C_c + \sum_1^n F_{si}$$

INTERACTION DIAGRAM

The use of interaction diagram is faster and simplest way for obtaining the strength nominal capacity of a column, in addition, it can be used for column design by assuming column dimensions then the required steel reinforcement will be obtained. In this research, the interaction diagrams are constructed according to the ACI 318M-08 provisions.

COMPUTER PROGRAM DESCRIPTION

The computer program is developed in Microsoft Quick-Basic Version 4.5. It is capable of producing points that describe the axial load versus moment interaction diagram for any short hollow-column under uniaxial bending. Input data for program include: the material and section properties, and the area and coordinates of each longitudinal bars. The output of the program consists of a series of data points (P and M values) that could be used to construct the interaction diagram for the hollow column. The program assumed a linear variation of strain over the depth of the section. Strain hardening of steel, tensile strength of concrete, and slenderness effects are ignored. In addition, the effect of thin walled section is out of the aspect of this research, hence h/H (the hollow ratio) was not be taken less than 0.2.

EXAMPLES

Example 1

Given: $H_x = 800$ mm; $H_y = 600$ mm; $h_x = 160$ mm; $h_y = 480$ mm; $d_s = 80$ mm; $f'_c = 25$ MPa; $f_y = 400$ MPa; $P_u = 1355$ kN and $M_{ux} = 1375$ kN.m.

Required: longitudinal steel area required to sustain applied loadings.

Solution

$$\gamma_x = \frac{H_x - 2h_x}{H_x} = \frac{800 - 2 \times 160}{800} = 0.8 \quad h_x / H_x = 160 / 800 = 0.2; \quad h_y / H_y = 480 / 600 = 0.8$$

∅ Figure ID 8 ($\gamma_x = 0.8$) $\phi P_n = P_u$ ∅ $P_n = 1355 / 0.65 = 2084.62$ kN, $\phi M_n = M_u$ ∅ $M_n = 1375 / 0.65 = 2115.4$ kN.m.

$$e / H_x = (2115.4 \times 1000 / 2084.62) / 800 = 1.27$$

$$\alpha_f = P_n / f'_c A_{col} = 2084.62 \times 1000 / (25 \times 800 \times 600) = 0.17$$

$$\text{ID 8: } \rho_t \cdot m = \frac{A_{st}}{A_{col}} \cdot \frac{f_y}{f_c} \Rightarrow 0.45 = \frac{A_{st} \times 400}{800 \times 600 \times 0.85 \times 25} \Rightarrow A_{st} = 11545 \text{ mm}^2$$

Design 10∅40 mm (5 at each side).

Example 2

Given: $H_x = 400$ mm; $H_y = 200$ mm; $h_x = 160$ mm; $h_y = 120$ mm; $d_s = 80$ mm; $f'_c = 20$ MPa; $f_y = 400$ MPa; $P_u = 593.78$ kN and $M_{ux} = 68.14$ kN.m.

Required: longitudinal steel area required to sustain applied loadings.

Solution

$$\gamma_x = \frac{H_x - 2h_x}{H_x} = \frac{400 - 2 \times 160}{400} = 0.6 \quad h_x / H_x = 160 / 400 = 0.4; \quad h_y / H_y = 120 / 200 = 0.6$$

∅ Fig. ID 13 ($\gamma_x = 0.6$) $\phi P_n = P_u$ ∅ $P_n = 593.78 / 0.65 = 913.511$ kN, $\phi M_n = M_u$ ∅ $M_n = 68.14 / 0.65 = 104.834$ kN.m.

$$e / H_x = (104.834 \times 1000 / 913.511) / 400 = 0.287 \quad \alpha_f = P_n / f'_c A_{col} = 913.511 \times$$

$$1000 / (20 \times 400 \times 200) = 0.57 \quad \text{ID 13: } \rho_t \cdot m = \frac{A_{st}}{A_{col}} \cdot \frac{f_y}{f_c} \Rightarrow 0.34 = \frac{A_{st} \times 400}{400 \times 200 \times 0.85 \times 20}$$

$A_{st} = 1154.54 \text{ mm}^2$ Design 4∅20 mm (one at each column corner).

CONCLUSIONS

The analysis and design of reinforced concrete hollow shaped cross sections subjected to axial compression and uniaxial bending are tedious and time consuming because

1. In the analysis, a trial and error procedure is required to find the depth of the neutral axis satisfying the equilibrium conditions.
2. In the design process, a trial and error procedure is required to find the steel ratio (ρ_t) satisfying the strength requirements.

While the simplicity of the present approach enabled the construction of new design charts can be used directly in design.

REFERENCES

[1]. Brondum-Nielsen, T. "Ultimate Flexural Capacity of Cracked Polygonal Concrete Sections Under Biaxial Bending", ACI Journal Vol.82, 1985, PP. 863-869.
 [2]. Hsu, T.C., "Channel-Shaped Reinforced Concrete Compression Members Under Biaxial Bending", ACI Journal vol.84, 1987, PP.201- 211.

- [3].ACI Committee 318, “Building Code Requirements for Reinforced Concrete and Commentary (ACI M-08/ACI 318 RM-08)”, American Concrete Institute, Detroit, 2008.
- [4].Hsu, T.C., “Biaxially Loaded L-Shaped Reinforced Concrete Columns”, Journal Structural Engineering, ASCE 111, 1985, PP.2576-2598.
- [5].Hsu , T.C., “ T-Shaped R.C Members Under Biaxial Bending and Axial Compression”, ACI Journal vol.86, No. 4 , July-August 1989, PP.460-468.

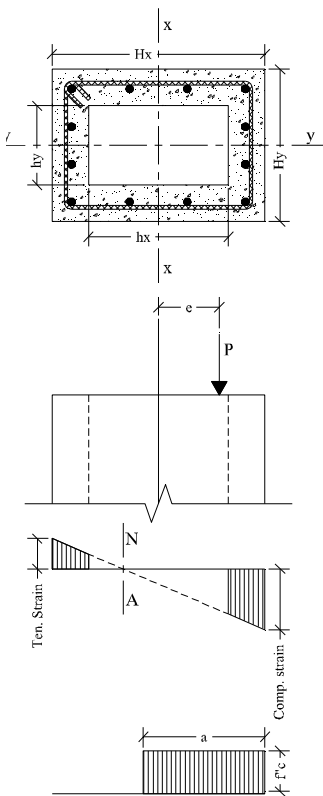

Figure (1-a)

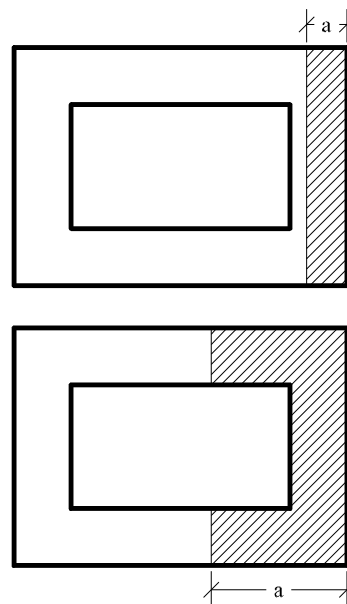
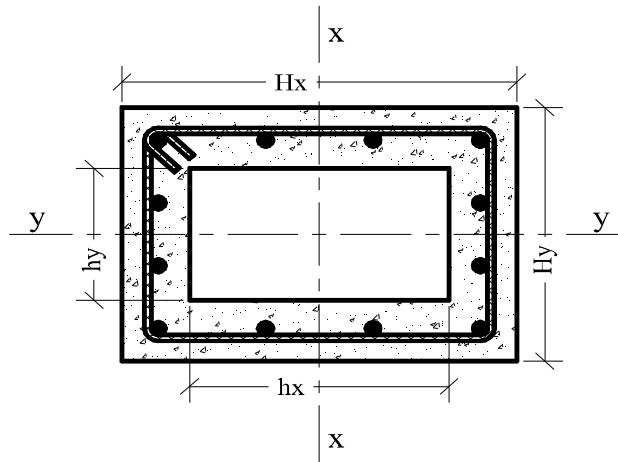

Figure (1-b)

Figure (1) Hollow Column Assmptions.



Figure(2) Typical Cross Section and Dimension.

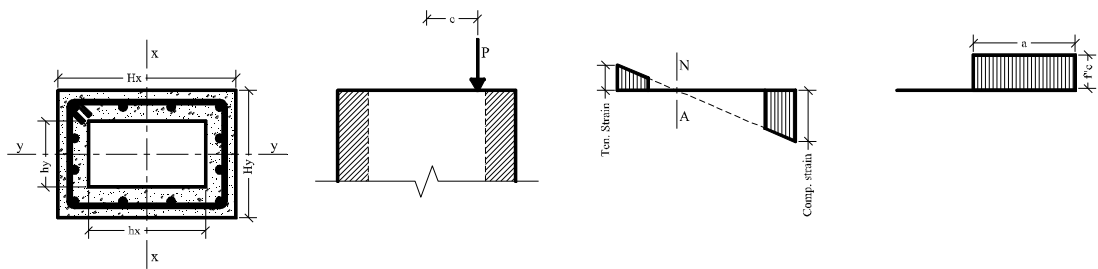

Figure (3) Loading assumption – Strain and Stress Distribution.

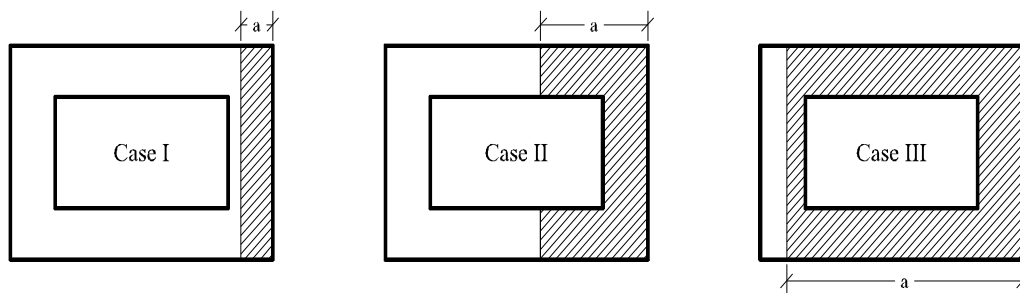
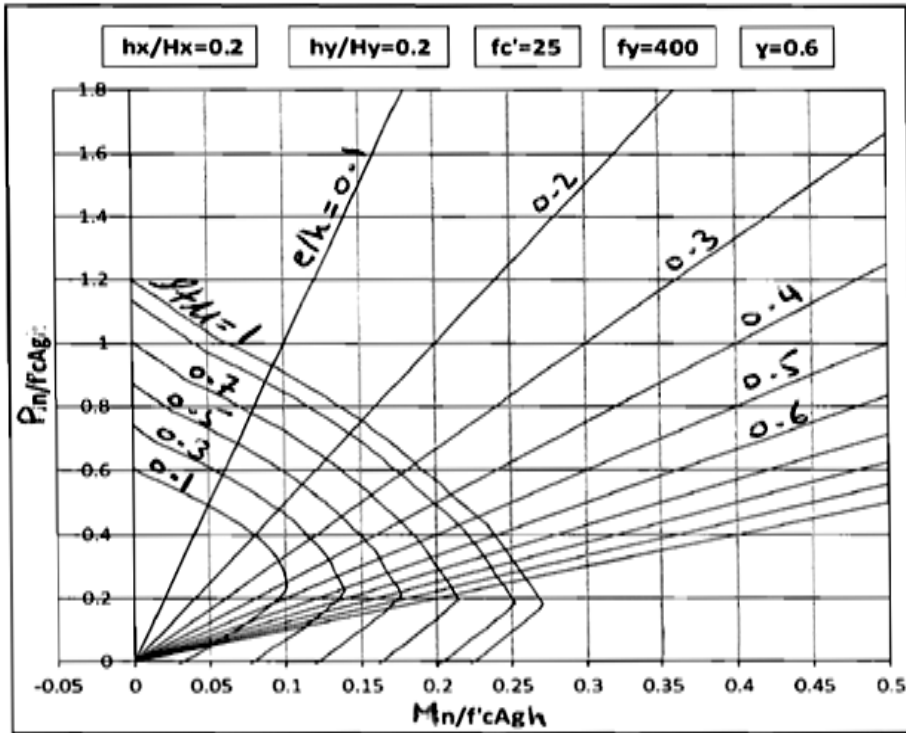
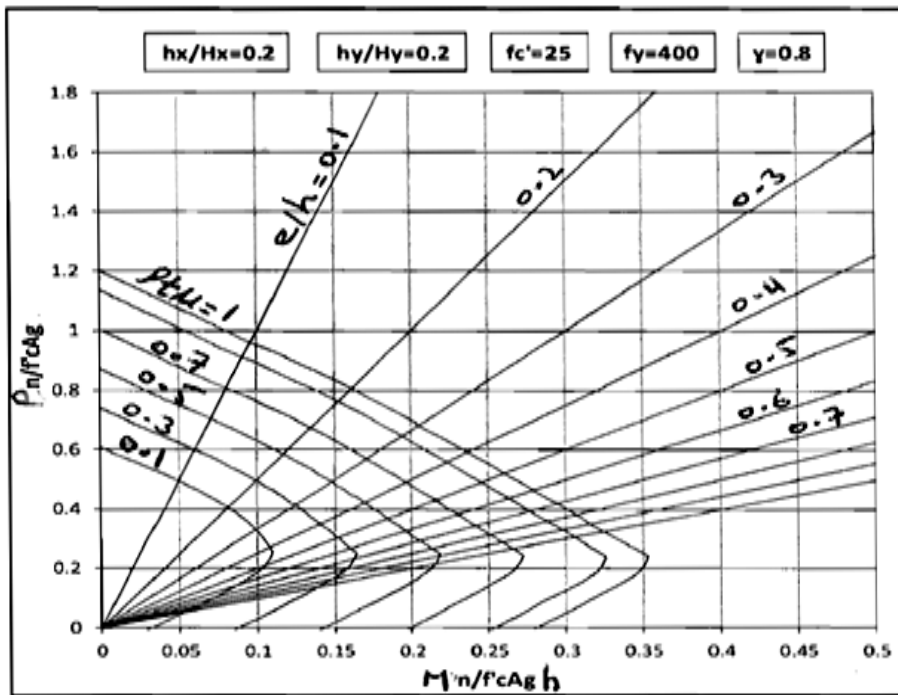

Figure (4) Possible Cases of Compression Zones.

Interaction Diagrams:



ID 1



ID 2

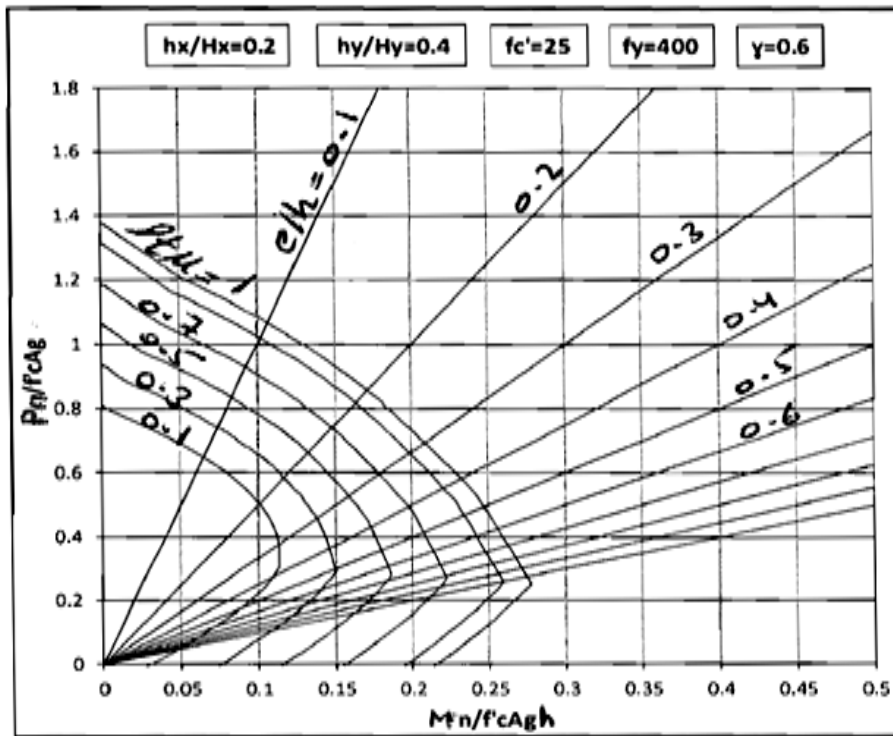

ID 3

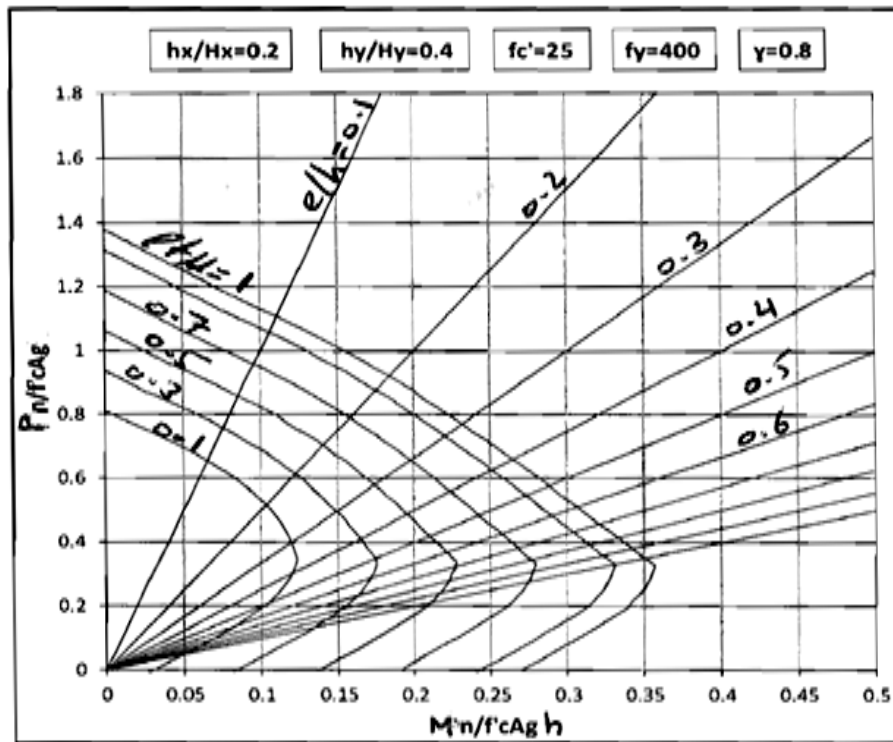

ID 4

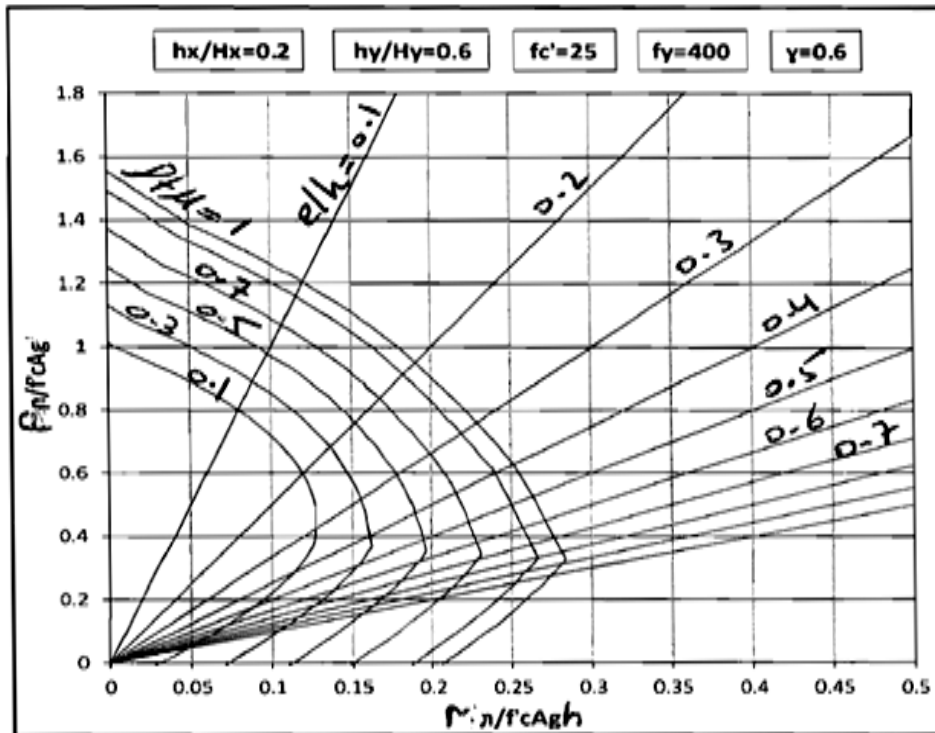

ID 5

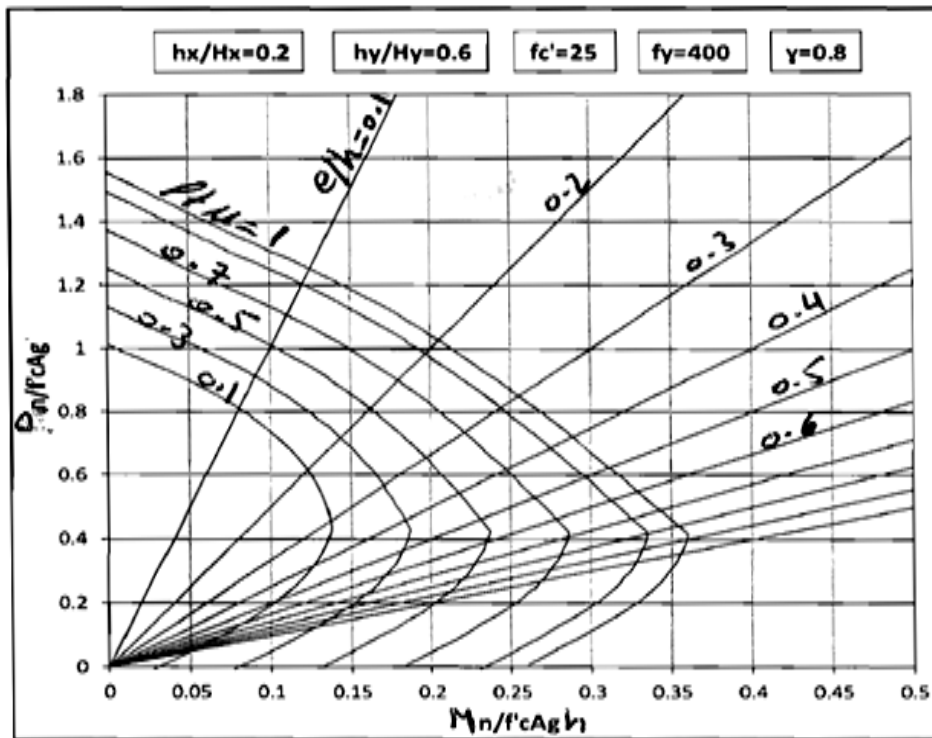

ID 6

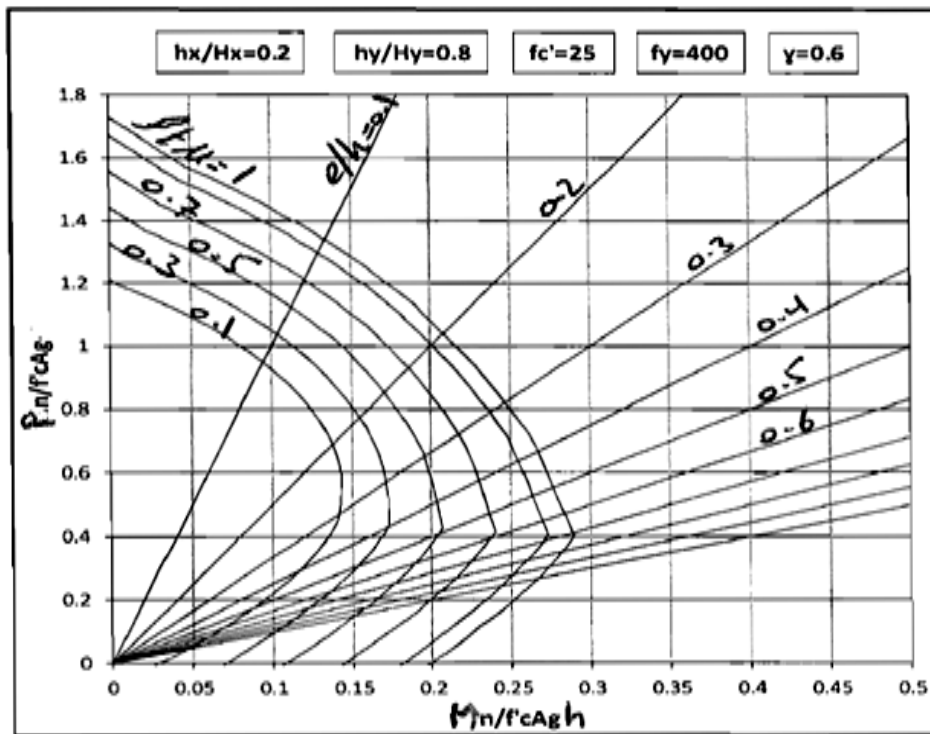

ID 7

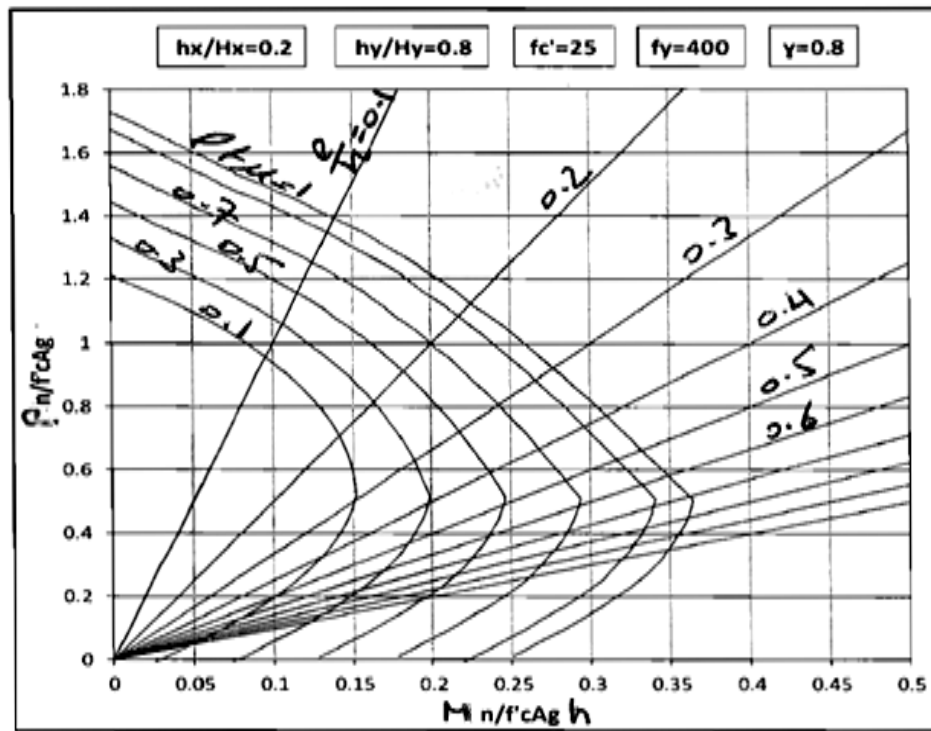

ID 8

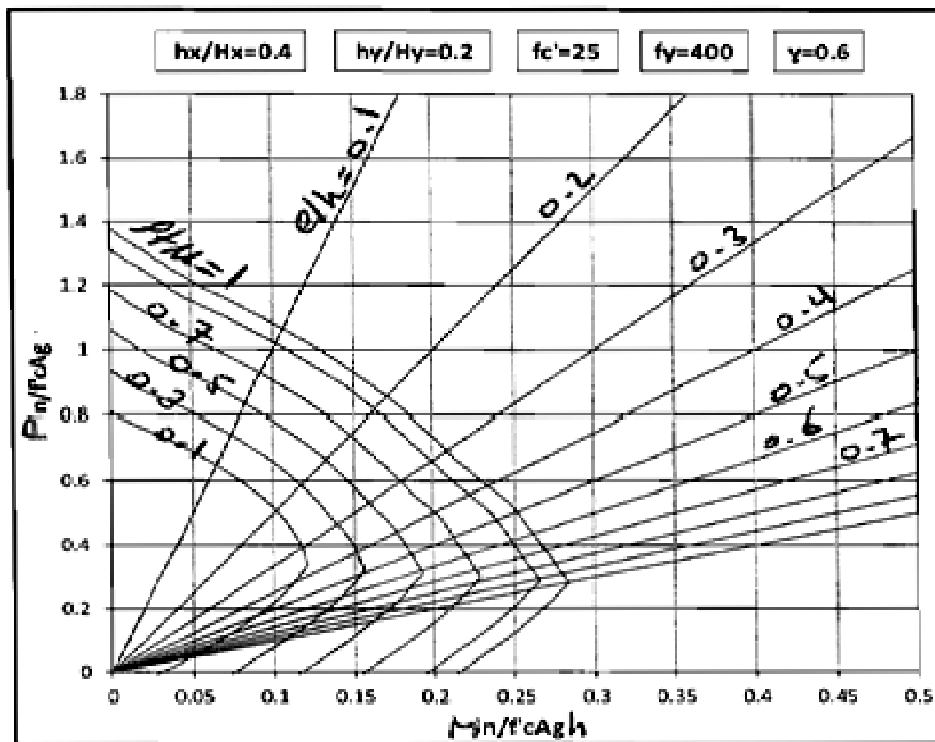

ID 9

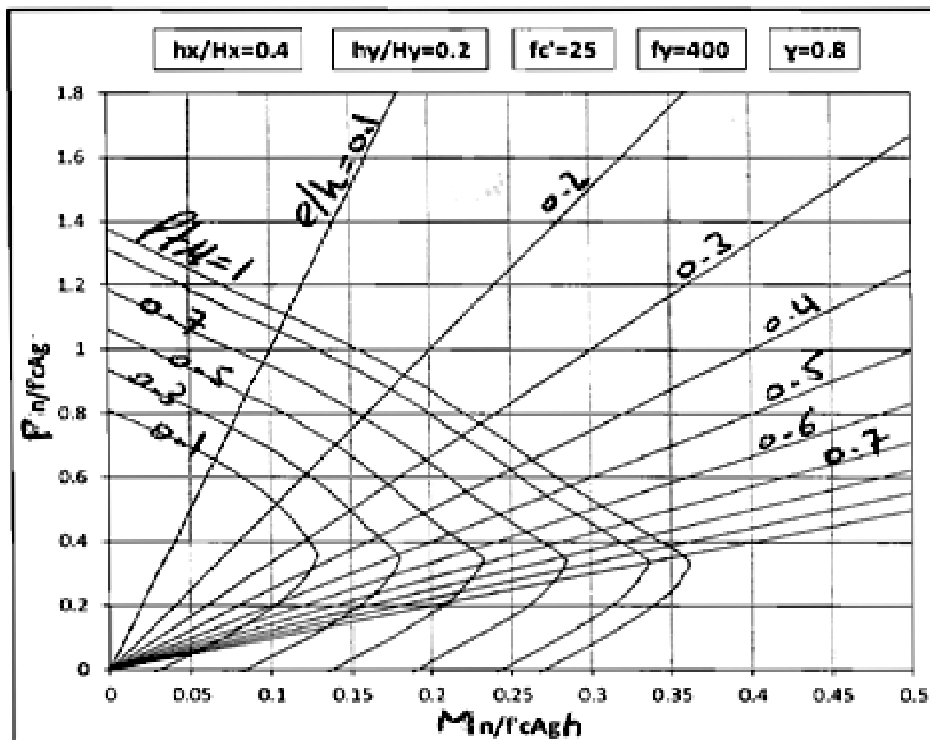

ID 10

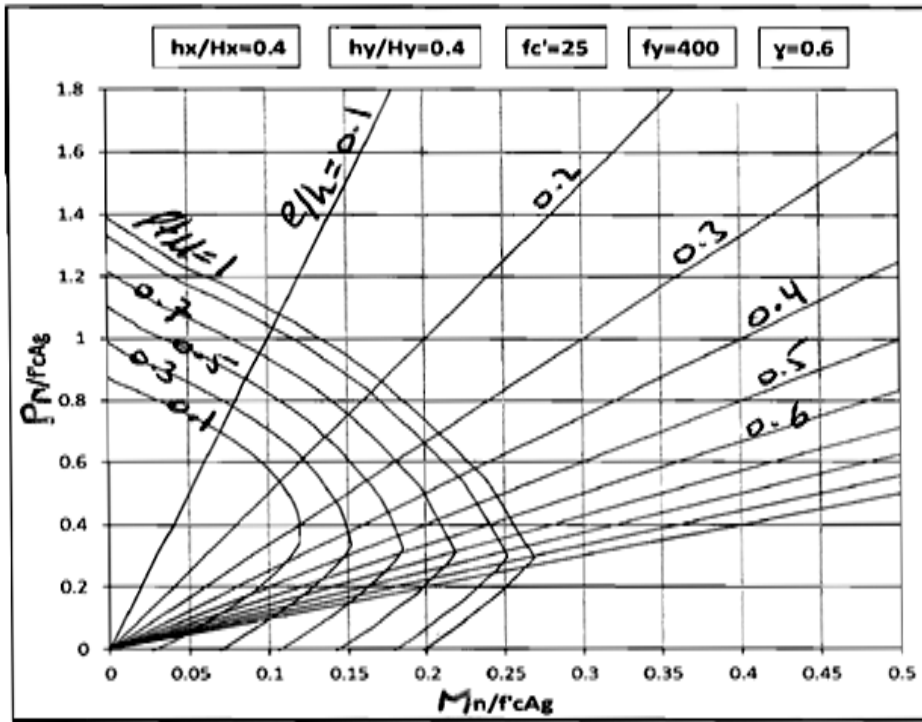

ID 11

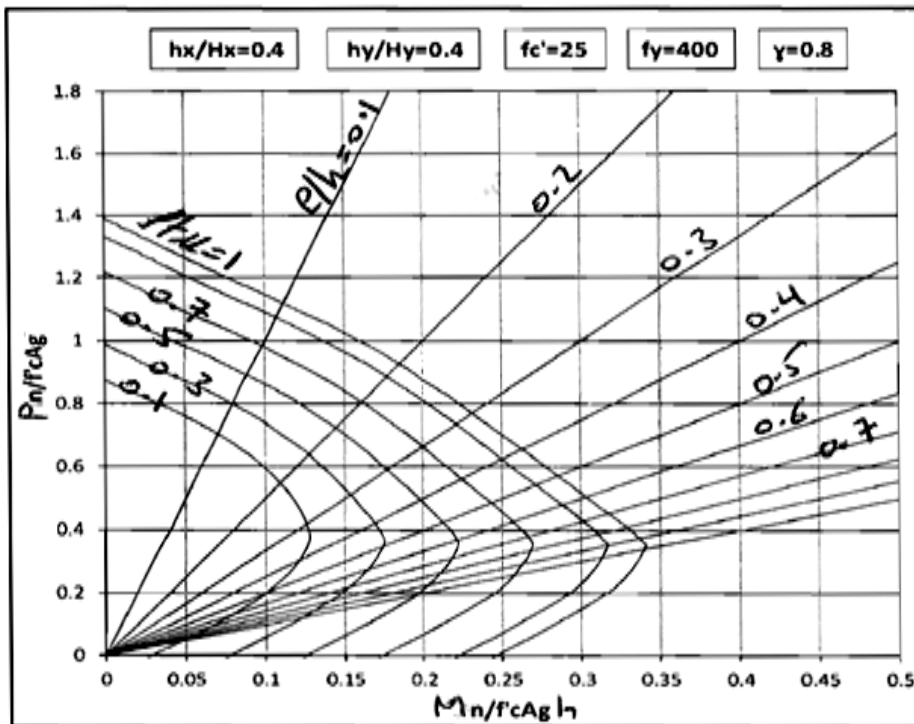

ID 12

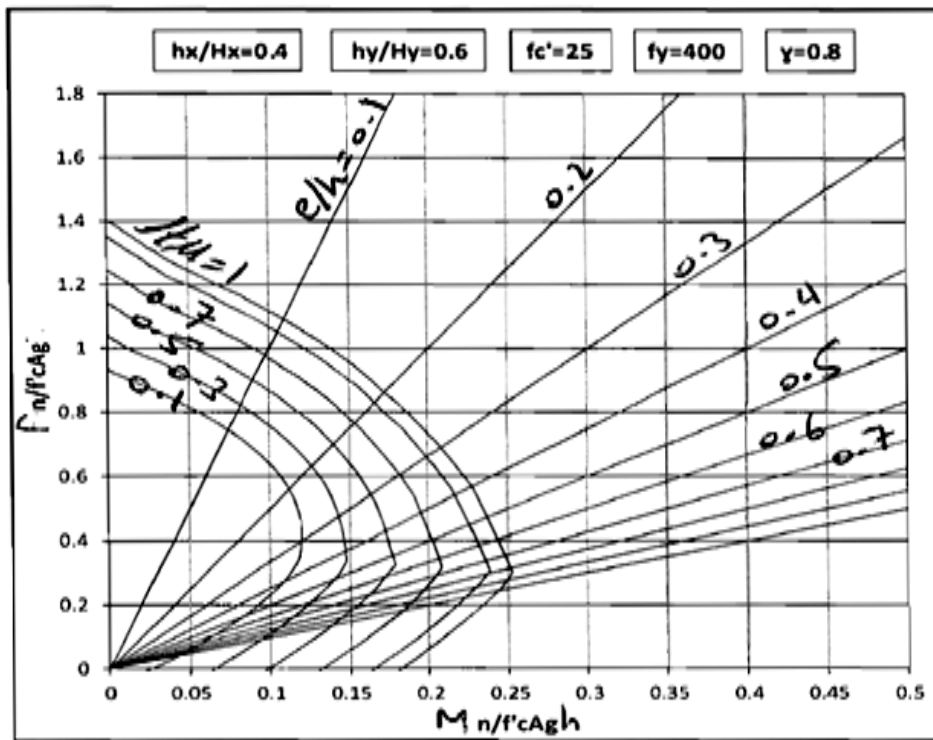

ID 13

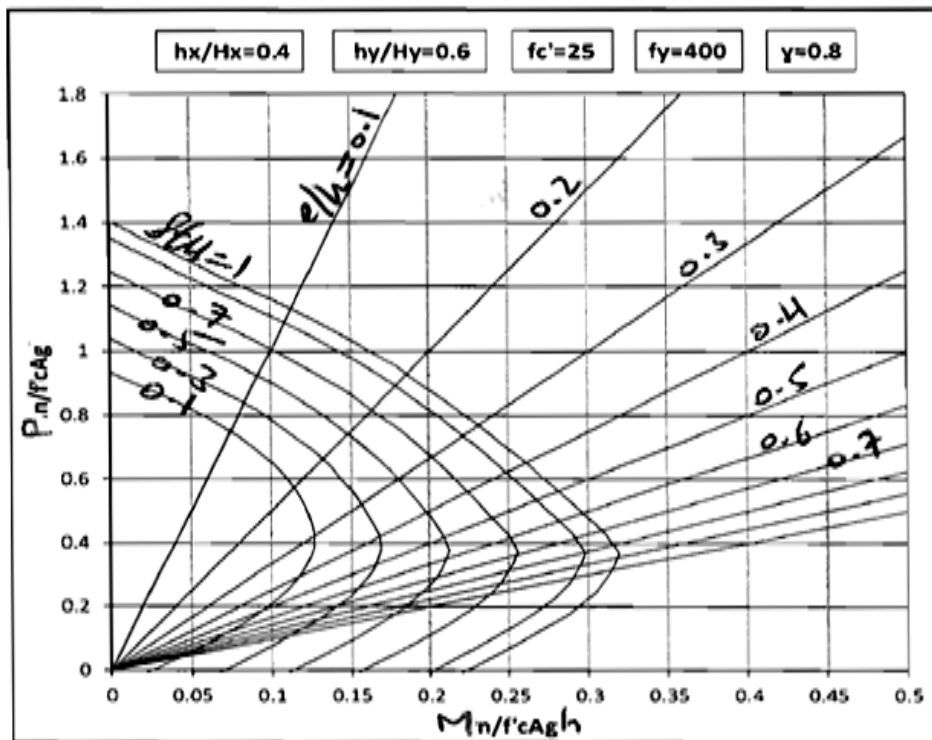

ID 14

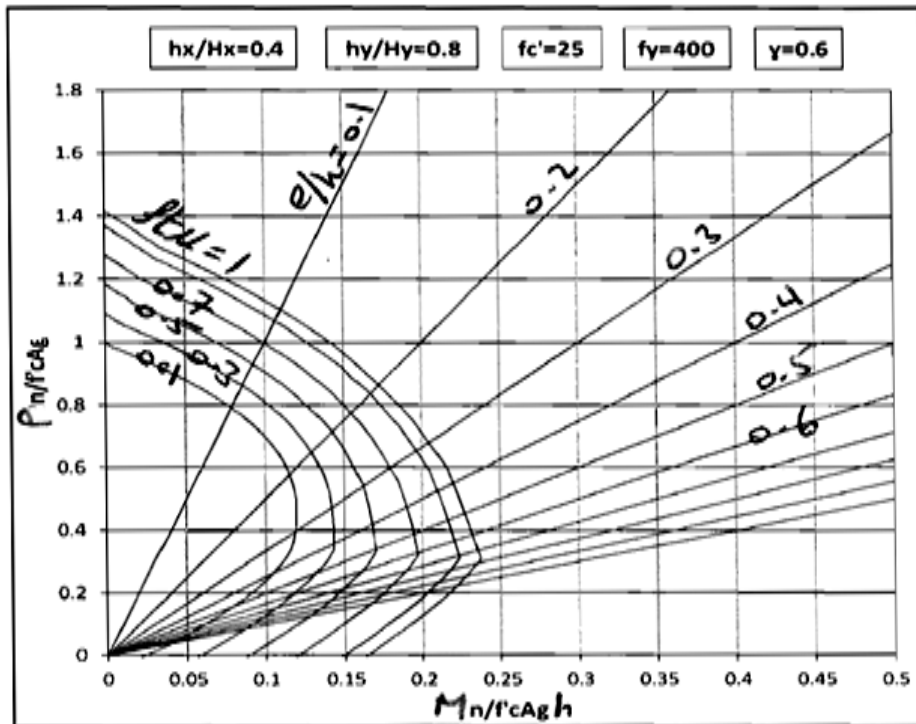

ID 15

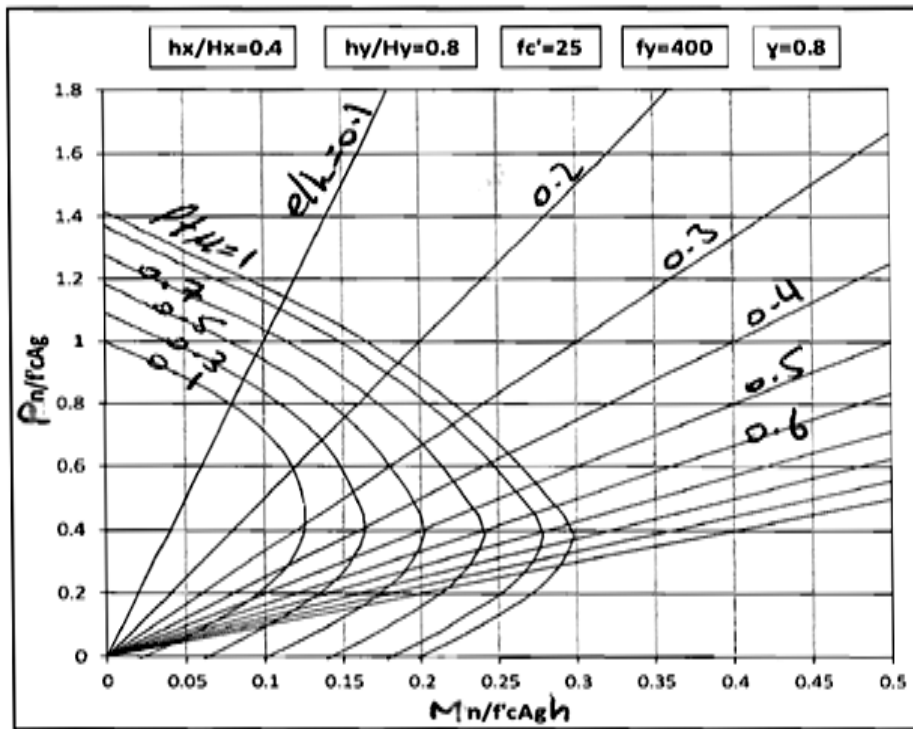

ID 16