

Effect of Orifice Shape and Bore-Area on Noise Attenuation in a Reactive Muffler

Dr. Muna S. Kassim

Engineering College, University of Al-Mustansiriya /Baghdad
munahdr@yahoo.com

Ehsan S. Ameen

Engineering College, University of Al-Mustansiriya /Baghdad

Hayder M. Mohammed

Engineering College, University of Al-Mustansiriya /Baghdad

Received on: 17/5/2012 & Accepted on: 6/12/2012

ABSTRACT

IC engines are a major source of noise pollution. Mufflers require specific design and construction. Considering various noise parameters produced by the engine, the conventional design does not include much of a parametric noise analysis or other engine characteristics. In this study, a muffler for internal combustion engine has been designed and manufactured. The performance characteristic and the effect on transmission losses are investigated for different types of orifice plates (circle and Square rectangle, triangle) with different bore areas and frequency. A good agreement with other works is obtained where the triangular bore shape orifice with minimum bore area is found to be the most effective.

Keywords: Muffler, Noise attenuation, Orifice shape

تأثير شكل ومساحة تجويف الفوهة على تخفيض الصوت في كاتم تفاعلي

الخلاصة

تعتبر محركات الاحتراق الداخلي من المصادر الرئيسية للتلوث الضوضائي، الكواتم تتطلب مواصفات وتصاميم محددة . بالنظر لتنوع معالم الضوضاء الصادرة عن المحرك فإن التصميم التقليدي لا يلبي كافة تفاصيل تحليل الضوضاء وخصائص المحرك الأخرى. في هذه الدراسة تم تصميم وتصنيع منظومة كاتم من النوع التفاعلي وتم اختبار تأثير شكل ومساحة تجويف الفوهة (الأورفس) على معامل الانتقالية للصوت بتغيير التردد باستخدام عدة اشكال (دائري، مربع، مستطيل، و مثلث) وبمساحة مقطع مختلفة حيث تم التوصل إلى نتائج تتوافق مع بحوث من مصادر أخرى ومن بين الاستنتاجات فإن الشكل المثلث ذو المساحة الأصغر هو الأكثر فاعلية.

Nomenclature and list of symbols

Symbol or expression	Definition	units
C	Speed of sound	m/s
T	Absolute temperature	Kelvin
P	Pressure	N/m ²
ρ	Density	Kg/m ³
γ	Ratio of air at constant pressure to constant volume	
λ	Wave length	Unit length
SPL	Sound pressure level	
SPL ₁	Sound pressure level at inlet	
SPL ₂	Sound pressure level at outlet	
dB	A logarithmic unit that indicates ratio of physical quantities usually (power or intensity) relative to a specified or implied reference level	
dBA	Shorthand for A-weighted measurements usually refers to noise and noisome effects on humans and animals, and is in widespread use in the industry with regard to noise control issues, regulations and environmental standards.	

INTRODUCTION

The term “noise” should not be confused with the term sound. Noise is the generation of sounds that are unwanted. With respect to traffic, noise would be the generation of sounds that affect the quality of life for persons near roadways. That is why the reduction of exhaust noise from engines is, now-a-days, an important issue. Attaching a muffler in the exhaust pipe is the most effective means of reducing noise. To select the proper model and type of silencer, many factors should be considered like the type of engine, the pressure drop, the volume of exhaust flow across the silencer and the degree of silencing. A well-designed silencer for proper application must satisfy the following five conditions, geometrical, aerodynamic, acoustical, Mechanical, and economic condition.

The acoustical condition specifies the minimum noise reduction required from the silencer as a function of frequency. The operating parameters must be known because large steady-flow velocities or large alternating velocities (high sound-pressure levels) may alter its acoustical performance. The aerodynamic condition specifies the maximum acceptable average pressure-drop (back-pressure) through the silencer at a given temperature and exhaust flow.

Exhaust gases are passed through the muffler to reduce the noise of engine combustion, at the same time, back pressure causes exhaust gases to remain in the engine cylinder after the exhaust stroke. While a certain amount of back pressure is vital to optimum performance, too much back pressure can result in loss of horsepower and excessive engine turbocharger operating temperatures. When this

happens, performance and fuel economy suffer. It may not take much to alter the balance or to affect engine operation.

Many studies are held to achieve perfect designs for mufflers and papers are published to discuss the design parameters. **Rahman, et. al.[1]** investigated the most effective means of reducing noise by changing the design of muffler. But, mufflers require specific design and constructions considering various noise parameters produced by the engine.

The conventional design does not include much of a parametric noise analysis or other engine characteristics.

A muffler for stationary petrol engine has been designed and manufactured and the performance characteristics, i.e. noise reduction capability of the muffler; has been tested and compared with that of the conventional muffler. The result has been found to be quite satisfactory.

In all muffler designs the tailpipe length may have an important effect. **Muna, et. al. [2]** found that the tailpipe acts as a resonant cavity that couples with the muffler cavity. In order to minimize the noise level, different pipe lengths of inlet and outlet (discharge) tubes are studied with a specific diameter. The conclusion was that the taller outlet pipes the higher noise attenuation.

Orifice plates are most commonly used as primary element for flow measurement in pipe line based on the principle of measurement of differential pressure created when an obstruction is placed in the fluid flow due to increase in fluid velocity. Orifice plate cover a wide range of applications of fluid and operating conditions they give an acceptable level of uncertainties at lowest cost and long life without require maintenance. The orifice plates are correctly finished to the dimensions, surface roughness and flatness to the applicable standard these plates are recommended for clean liquid, gasses & steam flow. The orifice plate bore can be made in many configurations to handle various flow measurement jobs.

Muthana et. al [3] built a test rig for a reactive muffler. Different orifice shapes are used with the same bore area to study the effect of the orifice shape on noise reduction. Also the effect of the number of orifices in one plate, also multi plate orifice is discussed. It has been found that the multi plate circle orifice and triangle orifice give the most suitable results.

In this paper, different bore-area orifices with different shapes (circle, Square, rectangle, and triangle) are used with the same test rig in references [2 & 3] to detect the effect of the area on noise attenuation in the muffler.

THEORETICAL CONSIDERATION

The restriction orifice plates are used to reduce the flow rate or to create a pressure drop. A restriction orifice (figure (1)) is denoted by "RO" or "FO". When specifying a Restriction Orifice, plate thickness "E" should be thick enough to reduce plate deflection to a minimum. (As a rule, the maximum pressure drop across a single orifice for a gas is 50%. For greater drops, multiple orifices may be used. Cavitation and excessive noise can be a problem) [4].

The active silencer is capable to reduce the exhaust noise from 91 dBA to 78 dBA after the tail pipe outlet, with a back pressure of 3 kPa to the engine.

The quantity most often used to measure the “strength” of a sound wave is the **sound pressure level** (L_p or SPL) measured with respect to a standard reference pressure of

$$p_{ref} = 2 \times 10^{-5} \text{ Pa.}$$

The sound pressure level can be calculated using the following formulas from reference[5]:

$$\text{SPL} = 20 \log_{10} (P / P_{ref}) \text{ (dB)} \quad \dots (1)$$

There are several parameters to describe the acoustic attenuation performance of an expansion chamber. These include the Noise Reduction (NR), the Insertion Loss (IL) and the Transmission Loss (TL). Among these acoustic parameters, the TL is the only one that can be easily calculated and measured according to the main aim of this paper. It is defined as the difference in the sound power level between the incident wave exciting the mufflers W_i and the transmitted wave W_t to an anechoic termination.

$$\text{TL} = 10 \log_{10} (W_i / W_t) \quad \dots (2)$$

$$\text{TL} = 10 \log_{10} \left[1 + 0.25 * \left(m - \frac{1}{m} \right)^2 \sin^2 kl \right] \quad \dots (3)$$

$$k = \frac{\omega}{c}$$

$$\omega = 2\pi f$$

$$m = \frac{D^2}{d^2}$$

Where

(ω): wave angular velocity

D=Diameter of the expansion chamber (15.25 cm)

d=Diameter of the inlet pipe (3.81cm)

(K) = No. of waves

(L)= Length of expansion chamber (24cm)

(c)= Sound speed (343m/sec)

The Transmission Coefficient in the silencer can be calculated theoretically from the following as in reference[6]

$$T_c = \frac{4}{[4 \cos^2 kl + (m + \frac{1}{m})^2 \sin^2 kl]} \quad \dots (4)$$

Experimental work

As shown in figure (2), the cylindrical muffler is made of an 18 gauge steel sheet with 24 cm length 15.24 cm diameter and two 10 cm length 3.81 cm diameter pipes. The muffler is made free of internal components except the orifice plate which will be changed during the test.

The test rig shown in figures (3 and 4) is made from the following components:

1-HP signal generator (shown in figure (5)): to generate sound signal with variable frequencies in the range of 0Hz to more than 1000Hz.

2- Amplifier.

- 3-loudspeaker:8 inch size
- 4- a box: to cover the loudspeaker, insulated from inside to prevent sound reflection.
- 5-acone-shape connector: attached to the box to force the sound wave pass in one path.
- 6- Pipes: to join the experiment parts(the signal generator, load speaker, box and cone)
- 7- Reactive mufflerwith changeable orifice.
- 8- Sound pressure level meter (shown in figure (6)): The sound level meter is the most common instrument used in measuring noise sources. Itworks by using a microphone to sense sound pressure, and electronic circuitry to convert the sound pressure to an SPL reading.
- 9- Orifice plates: a collection of orifice plates with different shape and bore area. Twomodels of bore-areafor orifice plates are used, the first 9.621 cm^2 and the second model 15.9 cm^2 .Different shapes of orifice plate are studied for both models, rectangular, circular, triangular, and square as shown in figures(7).These orifice plates are worked from 16 gauge steel sheet by CNC machine in a local workshop.

The signal generator is connected to the amplifier which is connected to the loudspeaker. The loudspeaker is isolated in the box to prevent sound reflection and also to prevent any external disturbance. The other end of the box is connected to the cone which is joined to the SPL meter.

The signal generator is turned on to generate sinusoidal wave signal with variable frequency from 50 to 500 Hz increasing 50 Hz each step. The SPL meter readings are recorded, then the test muffler is placed at the con end and the SPL meter is placed at the mufflers other end. The orifice plates are fixed using an adhesive paste which is can be removed easily to change the plates.

The noise test is repeated eight times for the eight orifice plate models and the results are recorded.

RESULTS

For each orifice case, TL and TC are calculated from the following

$$TL = SPL_1 - SPL_2$$

$$TC = SPL_2 / SPL_1$$

The values of TL and TC are analyzed graphically due to the frequency. Figures (8, 9, 10, and 11) represent TL values for circular, rectangular, square, and triangular orifices respectively discussing the effect of bore area. In figure (12),a comparison between TL values for the four models with large areas is made. Figure (13)shows the same comparison for the small areas.

Figures (14, 15, 16 and17) represent TC values for circular, rectangular, square, and triangular orifices respectively discussing the effect of bore area. A comparison for TC values between the four models is shown in figures(18 and 19).

DISCUSSION AND CONCLUSIONS

Taking a fast view in TL figures (8 – 11) where the maximum sound losses are required and TC figures (14 – 17) where the minimum sound transmission coefficient is required.It is obvious that the orifices with smaller area are

preferable, except at some frequency values where it is assumed to be the effect of natural frequency.

The above clearness is not presented when comparing between the orifices bore shapes. The values of TL and TC in figures(12, 13, 18, and 19) are altering and the shape curves are interchanging during frequency growth from 50 to 500. For example, in figure(13), it can be noticed that the rectangular orifice is better during the range of (50 – 125) Hz, the square orifice then take place in the range (125-175) Hz. The rectangular orifice comes back to view from 175 to 275 Hz. The better values for the next interval are for the square orifice from 275 to 350. Then the circular orifice works from 350 to 450 Hz and the square orifice will be back for the next 50 Hz.

In order to give a conclusive answer for the best shape to be used in the whole domain (50 – 500) Hz another style to present the results is necessary. Figures(20&21) give the trend line with polynomial equations of the second order for the results of figures(13&19).

From figure (21), it can be concluded that the triangular shape orifice is the most suitable shape to be used and the circular comes after.

Figure(20) gives the same conclusion and this agrees with the conclusions in reference[3].

Also to recognize the effect of the orifice in the muffler, the polynomial trend lines of second order in figure(22) show a comparison between the theoretical values of TL (empty muffler without orifice) from equations (3 & 4) and the experimental values with and without orifice.

REFERENCES

- [1] M. Rahman, T. Sharmin, A F M E. Hassan, and M. Al Nur, " Design And Construction Of A Muffler For Engine Exhaust Noise Reduction" Proceedings of the International Conference on Mechanical Engineering 2005 (ICME2005) 28- 30
- [2] Muna S. Kassim, Muthana K. Al-Doory, and Ehsan S. Al-Ameen "Experimental Investigation for the Effect of Inlet & Outlet Pipe Lengths on Noise Attenuation in a Muffler" Engineering and Development Journal, accepted to publish 2012.
- [3] Muthana K. Al-Doory, Muna S. Kassim & Ehsan S. M. Al-Ameen " The Effect of Orifice Shape On Noise Reduction in a Muffler Experimentally" Proceedings of the 5th Scientific Conference, Wasit University, Wasit, Iraq December 13-14 2011
- [4] Orifice Plates, universal type orifice plates / cat no. sp500 /Superior Products, Inc. 20550 Madison Street, Torrance, CA 90503
- [5] Beranek, L.L. & Ver, I.L. "Noise and Vibration Control Engineering", John Wiley & Sons Inc., 1992.
- [6] Harris, C.M. " Hand-Book of Noise Control", McGraw-Hill book company, 1979.

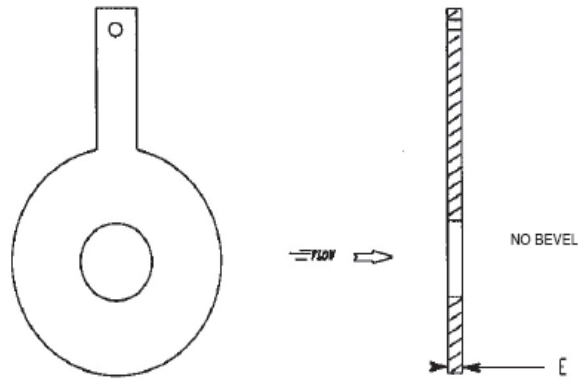

Figure (1)Restriction Orifice plate

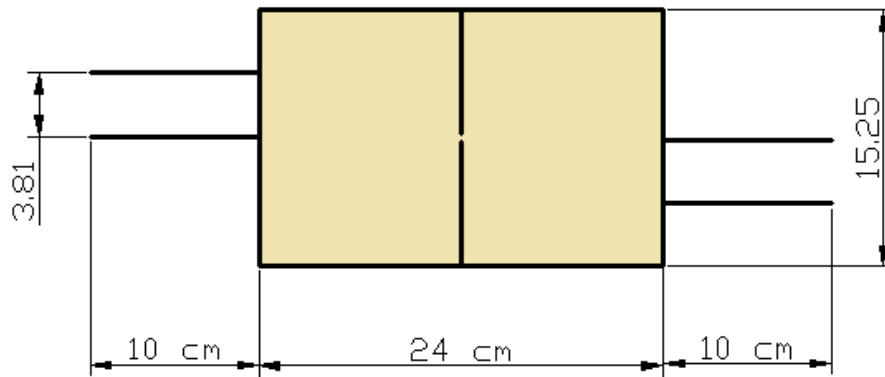

Figure (2) cross sectional area for the used silencer

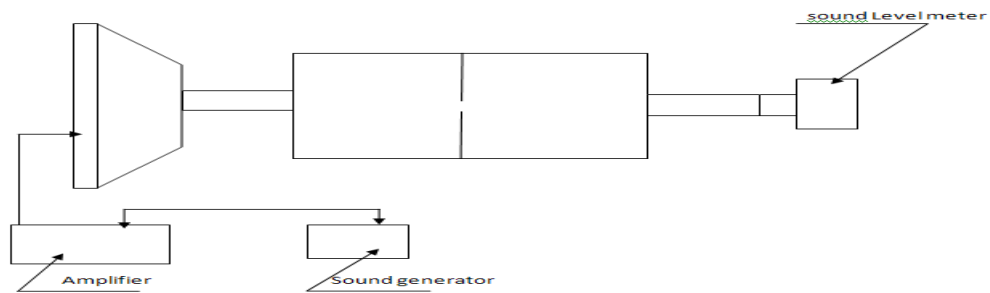

Figure (3) the test rig arrangement

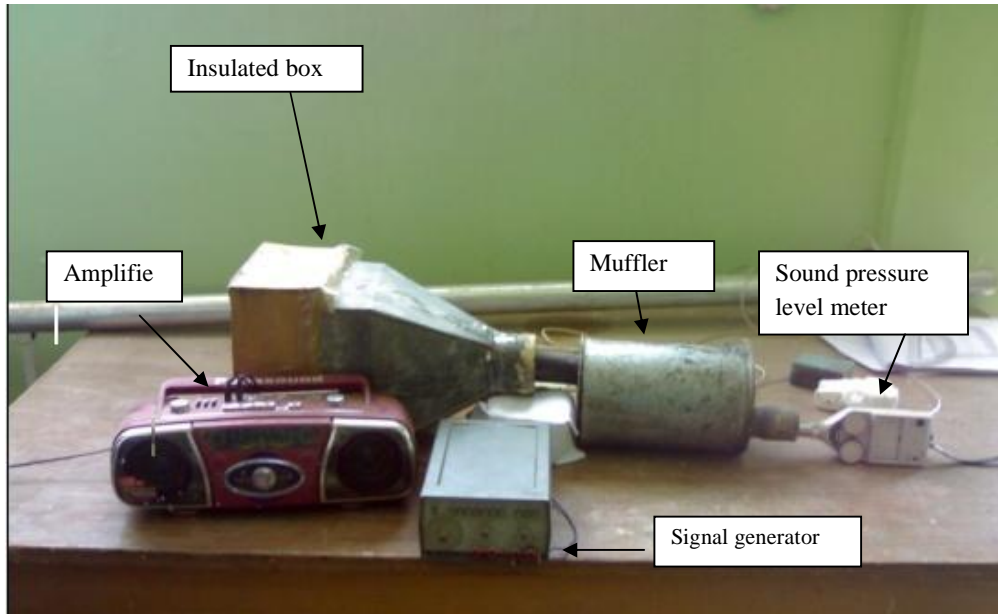

Figure (4) the test parts photo.



Figure (5): The function generator



Figure (6): SPL meter

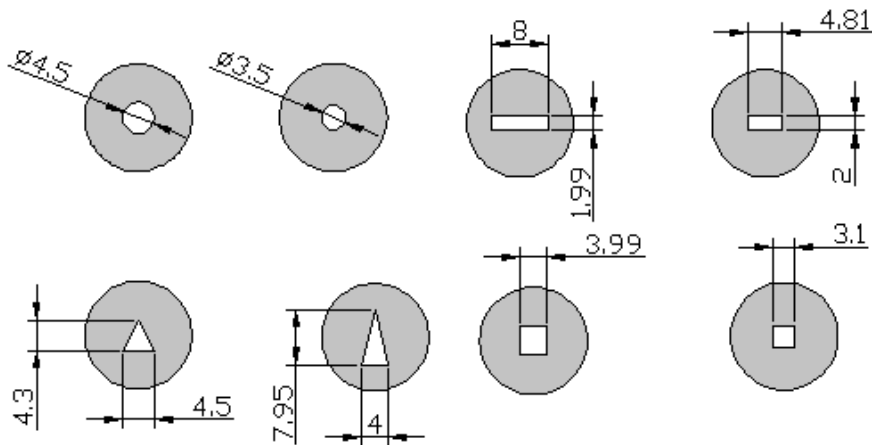

Figure (7): a schematic for the orifice plate samples

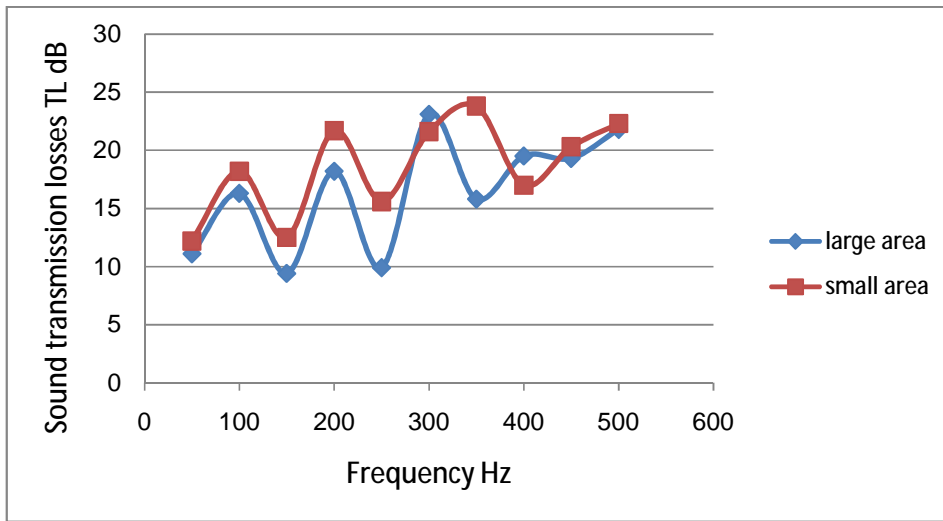

Figure (8): TL for Circular orifice case

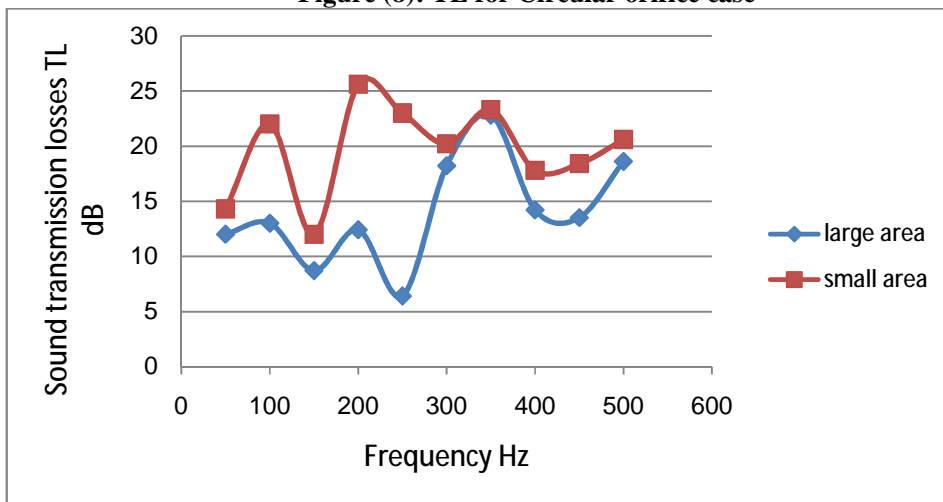

Figure (9): TL for Rectangular orifice case

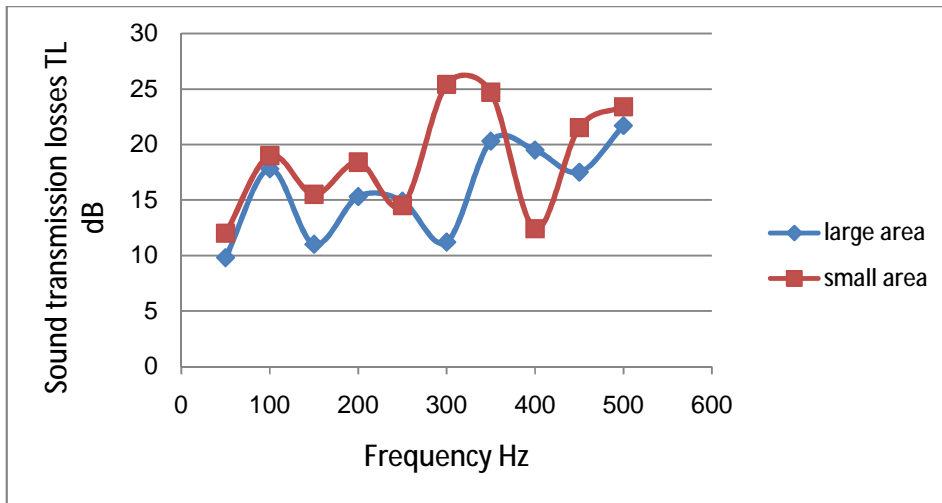

Figure (10): TL for Square orifice case

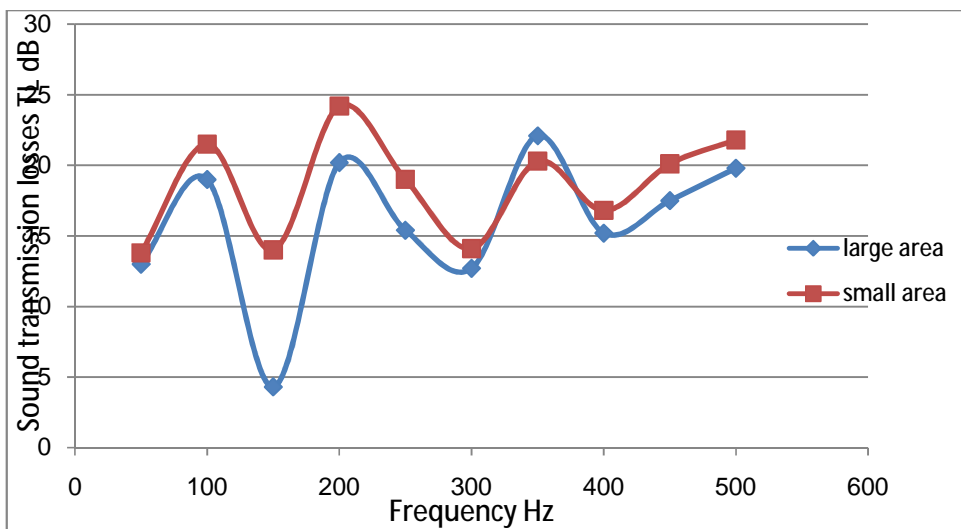

Figure (11): TL for Triangular orifice case

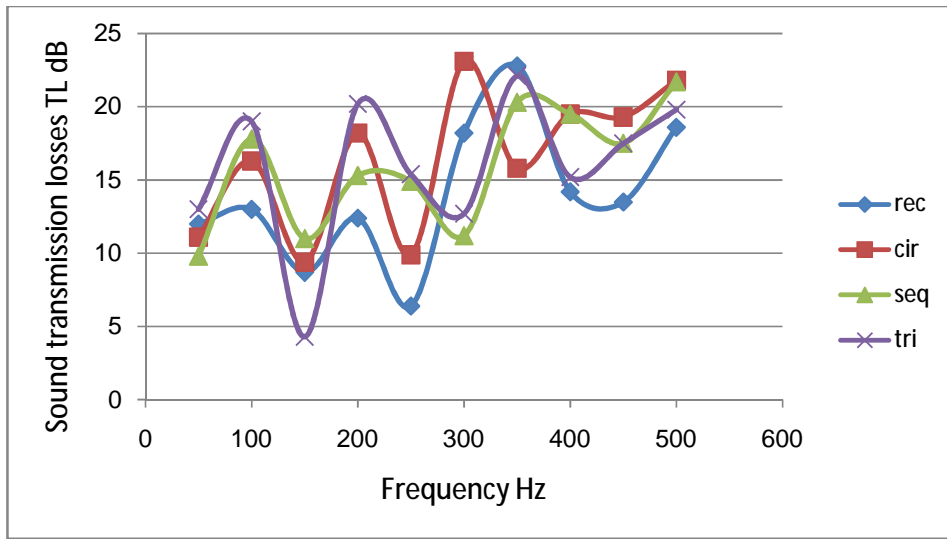

Figure (12): comparison for TL values between the four models with large area

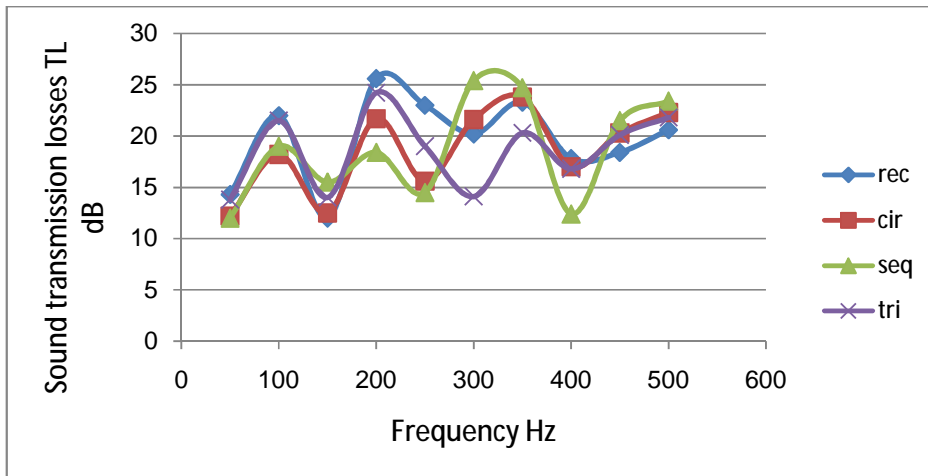

Figure (13):comparison for TL values between the four models with small area

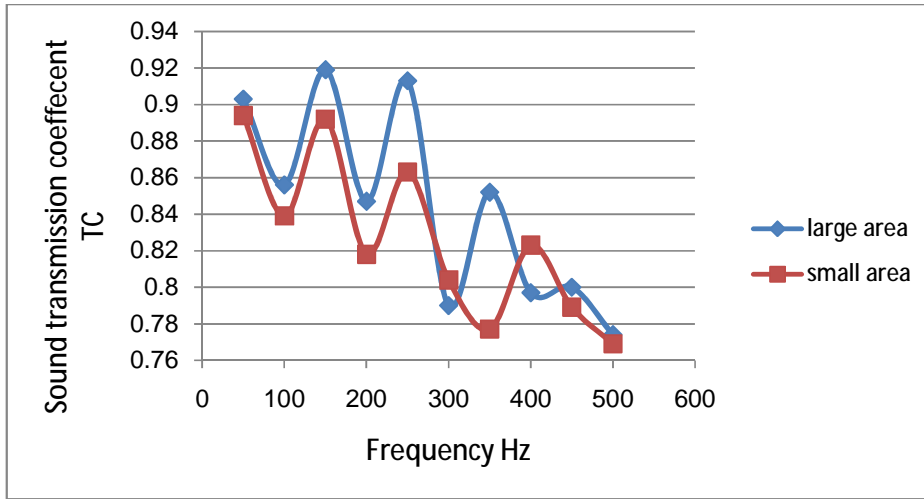
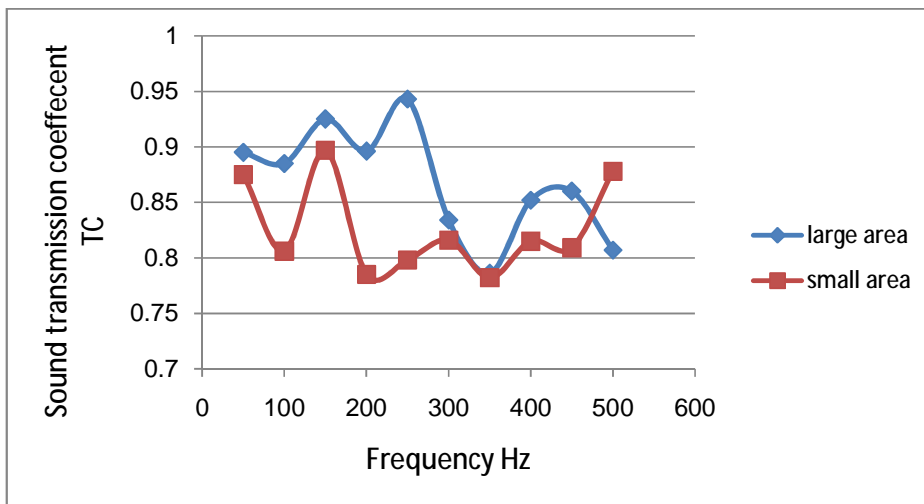

Figure (14):TC for Circular orifice case



Figure(15):TC for Rectangular orifice case

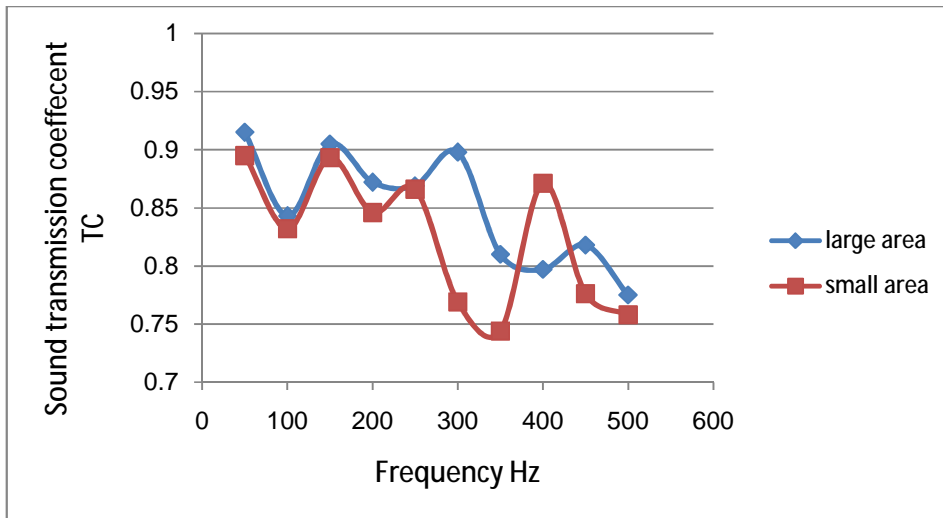

Figure (16):TC for Square orifice case

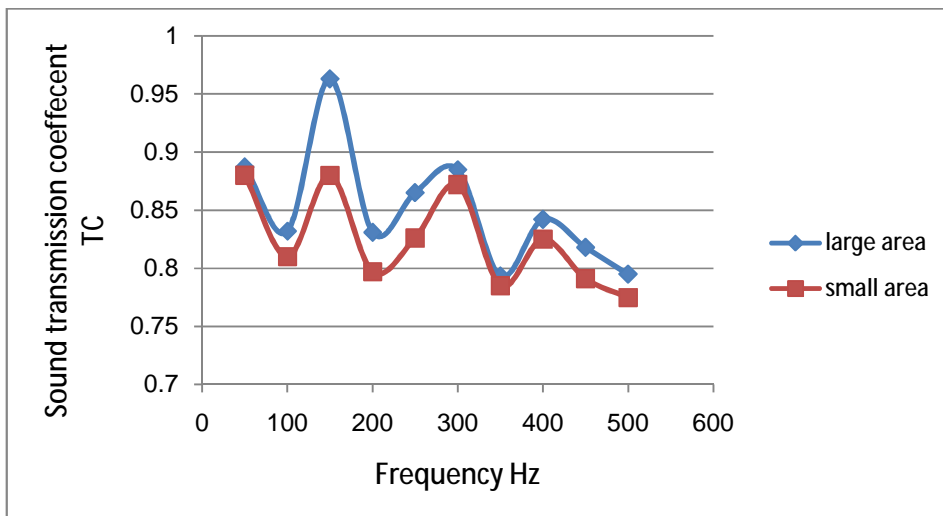
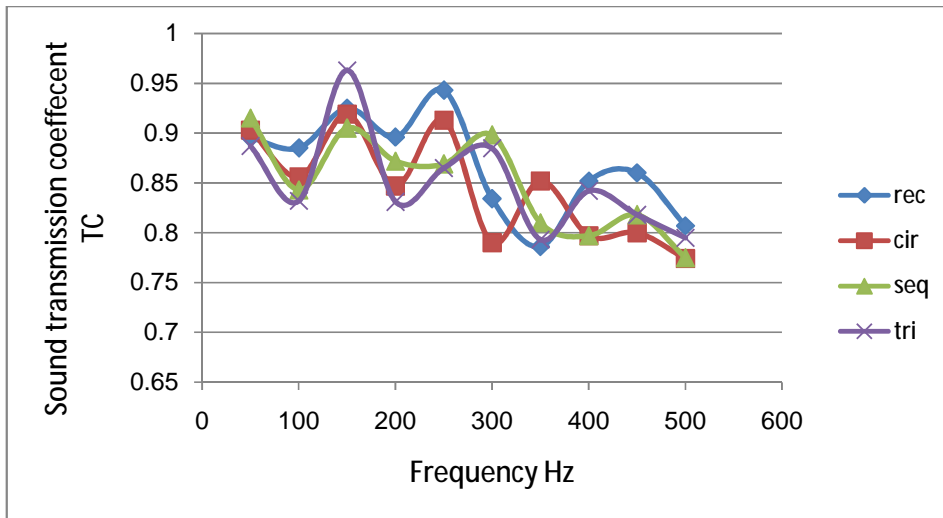

Figure (17):TC for Triangular orifice case



Figure(18):comparison for TC values between the four models with large area

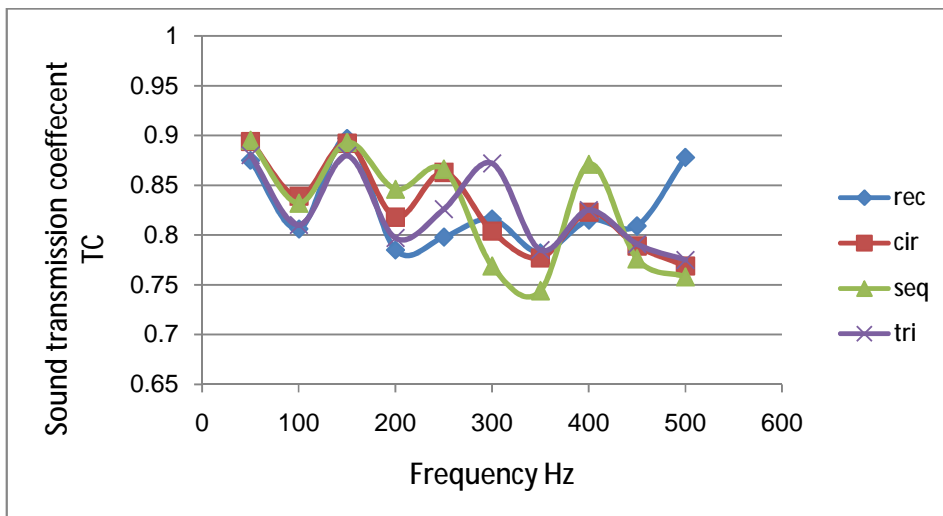

Figure (19):comparison for TC values between the four models with small area

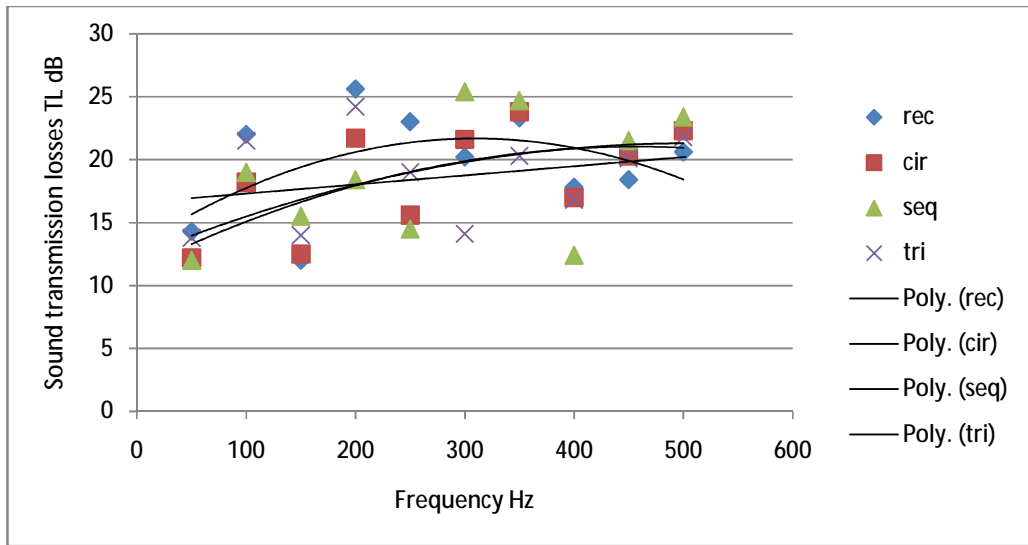
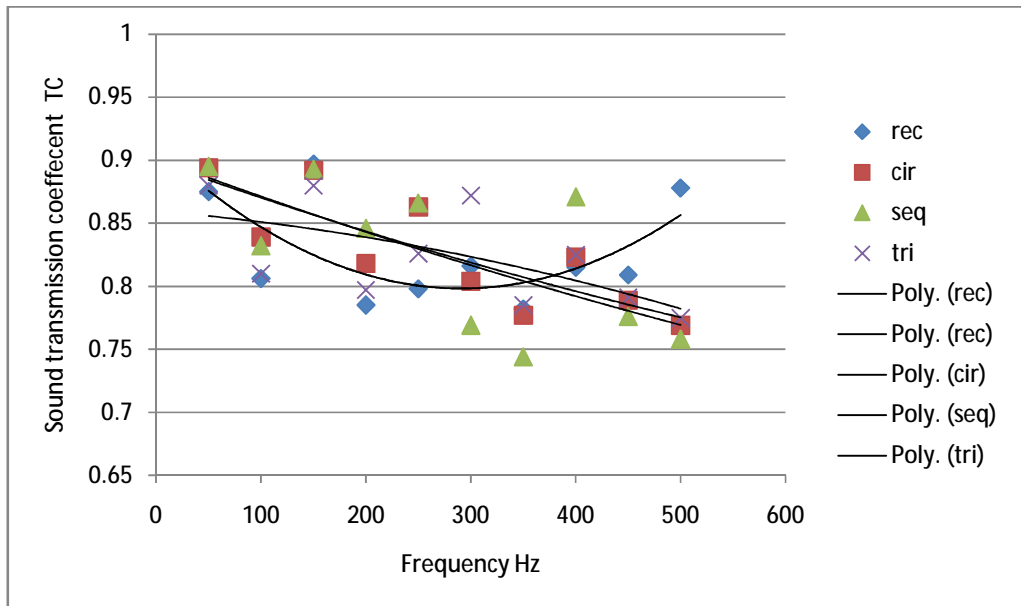

Figure (20): the trend polynomial second order values of figure (14).



Figure(21): The trend polynomial second order values of figure (20).

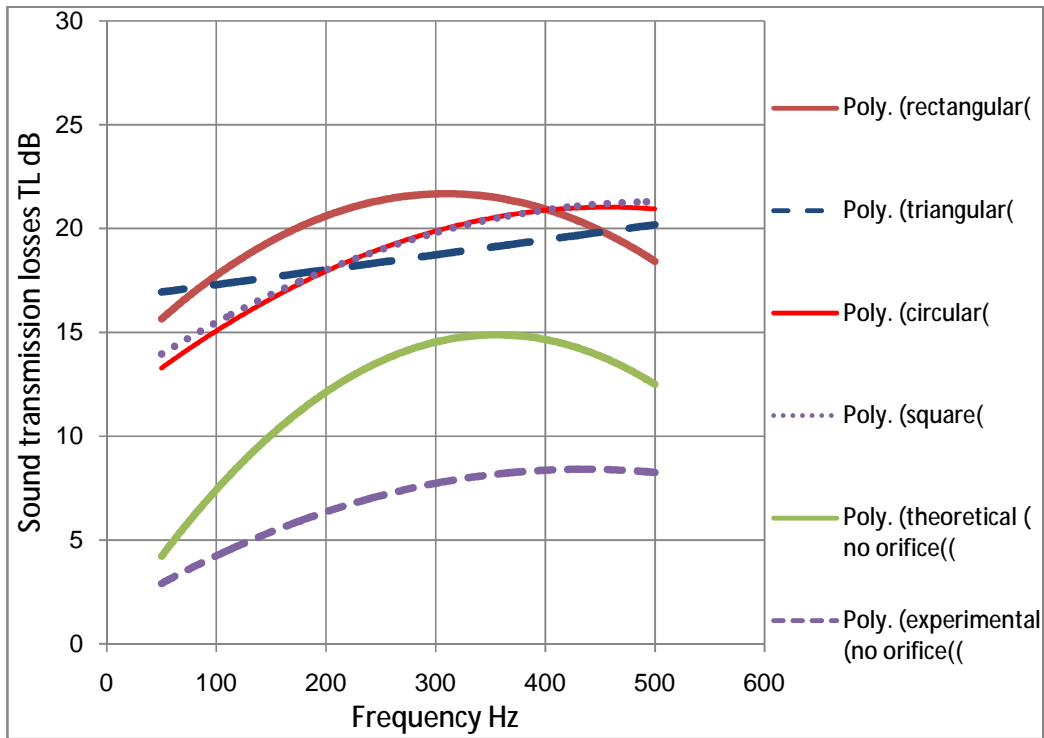

Figure (22):A comparison for the theoretical values of (TL with no orifice) and the experimental values with and without orifice.