

## The Effect of Tool Geometry for Resistance Spot Welds on Crack Growth in Specimens of Mild Steel

Dr. Nadhim M.Faleh

Mechanical Engineering Department, Al-mustansiriyah University/Baghdad  
Email:Abo.mohomod@yahoo.com

Received on: 4/11/2012 & Accepted on: 7/3/2013

### ABSTRACT

A mechanism of crack growth was investigated in resistance spot welds of mild steel. The experiments in this study were designed to investigate the effects of the electrode cap geometries on fatigue life of the resistance spot weld specimens. Two types of electrode cap geometries were used. These types are 4.8 mm and 6.3 mm nose, used with the same shank in welding operations of 2mm mild steel plate. To obtain the goal, operating factors were precisely controlled, especially the electrode force and welding current of spot welds, to keep the same operating conditions while changing the electrode geometries. The life test results showed an improvement in the fatigue life of resistance spot welds. The increment was 30% in heavy loads and 10% in low loads based on tool geometry. The improvement in the fatigue life was produced by reducing the diameter of the nose in the geometry of the tool.

**Keywords:** Résistance Spot Welding, Fatigue, Crack Propagation, Mild Steel

تأثير شكل العدة لعملية اللحام النقطي المقاوم على نمو الشق لوصلة من الفولاذ

### الخلاصة

اهتمت الدراسة بميكانيكية نمو الشق في وصلات اللحام النقطي المقاوم. التجارب في هذه الدراسة قد استهدفت التحقق من تأثير شكل عدة اللحام النقطي على عينات اللحام النقطي المقاوم. وقد استخدم نوعين من التصميم لعدة اللحام. هذان النوعين هما بقطر 4.8 ملم وقطر 6.3 ملم للمقدمة مع نفس الماسك في عملية لحام صفيحة فولاذية ذات سمك 2 ملم. لاجل انجاز هدف الدراسة، تم السيطرة بدقة على العوامل المؤثرة في التشغيل وخاصة ضغط العدة والتيار المقاومة للحام النقطة، لاجل ضمان ظروف تشغيل متساوية مع تبديل شكل العدة. نتائج فحص العمر وضحت وجود تحسن في العمر الكلاسي للتوصيلة بمقدار 30% عند الاحمال العالية و10% عند الاحمال الواطئة، استنادا الى شكل العدة. التحسن في عمر الكلال قد نتج بتقليل قطر مقدمة شكل العدة.

RSW – Resistance spot weld  
d – Nugget diameter  
t – Sheet thickness  
F<sub>e</sub> – electrode force  
I<sub>w</sub> – Welding current  
E L Endurance limit

## INTRODUCTION

Electrical resistance spot welding is a widely used technique in the automotive industry to join sheet steels for uni-body and body on frame structures. The integrity of the uni-body structure relies on the strength of spot welds. The typical car uni-body structure contains more than 3000 spot welds to join the sheet steels [1]. Geometric shapes of the spot welds that subjected to various loads applied on the spot welds induce stress concentration that can lead to fatigue crack initiation at periphery of the spot weld [2]. The cracks can degrade structural integrity and increase noise and vibration of the vehicle structure. Therefore, the fatigue performance of the spot welds should be investigated in vehicle structure design [3].

Kang [4] investigated the fatigue performance of resistance spot welds in three sheet stack-ups. The paper describes the fatigue characteristics of spot welds for three equal thickness sheet stack-ups of a Dual Phase (DP600) welded to itself and a Mild steel welded to itself under tensile shear loading. The experiments were designed to investigate the effects of electrode tip geometries, surface indentation levels, and base metal strengths on fatigue life of the tensile shear spot welds.

Tran [5] investigated the effects of weld geometry and sheet thickness on stress intensity factor solutions for spot and spot friction welds in lap-shear specimens of similar and dissimilar materials. In that paper, three-dimensional finite element analyses for spot welds with ideal geometry in lap-shear specimens of different materials and thicknesses were first conducted. The computational results indicate that the stress intensity factor and J integral solutions based on the finite element analyses agree well with the analytical solutions and that the analytical solutions can be used with a reasonable accuracy.

Lin [6] studied the spot welding, especially the stress intensity factor solutions for spot welds in lap-shear specimens. Based on the J integral, the closed-form solutions are used to develop the analytical solutions of the mode I stress intensity factor for spot welds in lap-shear specimens of large and finite sizes. The analytical solutions of the mode I stress intensity factor based on the solutions for infinite and finite square plates with an inclusion are compared with the results of the three-dimensional finite element computations of lap-shear specimens with various ratios of the specimen half width to the nugget radius.

Rathbun [7] investigated the fatigue Behavior of Spot Welded High-Strength Sheet Steels and the effects of the loading conditions with tensile shear, coach peel, and cross tension specimens. The setup of operation as shown in Figure (1).

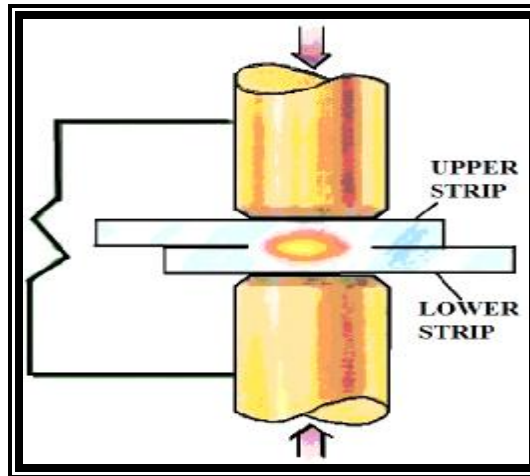

Figure (1) shows the RSW process.

**EXPERIMENTAL WORK**

The a lap-shearspecimen was made by using a 32mmx90mm Mild steeloverlap area. The chemical compositions of the sheet steels areshown in Table (1) the thickness of the mild steel was 2 mm.

**Table (1) Chemical composition of Mild Steel specimens.**

<b>C</b>	<b>Si</b>	<b>Mn</b>	<b>P</b>	<b>S</b>	<b>Cr</b>	<b>Mo</b>	<b>Ni</b>
0.001	<0.001	0.077	0.008	0.012	0.023	0.004	0.013
<b>Al</b>	<b>Cu</b>	<b>Nb/Cb</b>	<b>Ti</b>	<b>V</b>	<b>Sn</b>	<b>Fe</b>	<b>B</b>
0.0264	0.032	0.01	0.0443	<0.001	0.001	99.748	<0.001

Experimental work in this study was done as the following steps:

(1)Welding operation was done by traditional resistance spot welding type Miller. Two types of electrode cap geometries are used. Those are 4.8 mm and 6.3 mm nose, named tool A and B respectively, as shown in Figure (2). For both types of tool used a same shank in welding operations is used, to obtain the same operating factors.

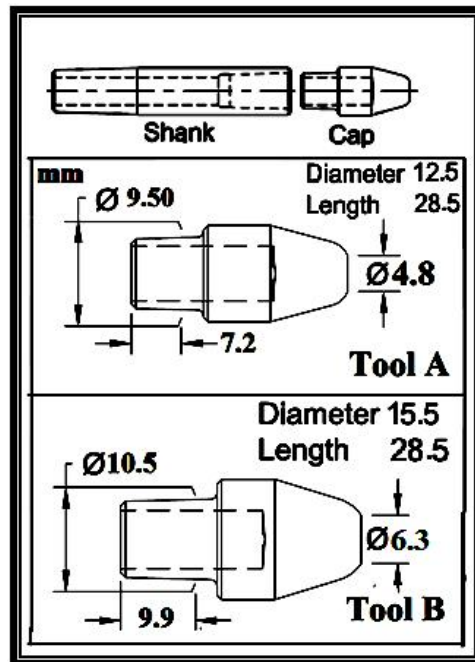

Figure (2) shows the Geometry and dimensions of the tool.

(2) Plates after welding were machined due to Figure (3). This observed specimens were tested to estimate the fatigue life. Fatigue test was done with Wohler test machine as shown in Figure (4).

(3) Variable fatigue test type (two-step) was done until failure on smooth surface of three types of specimens; specimen of base material, welded specimen by tool type A and welded specimen by tool type B. Two samples of each type were tested under (low-High), (High-low) loading to get the variable results, as shown in Figure (5).

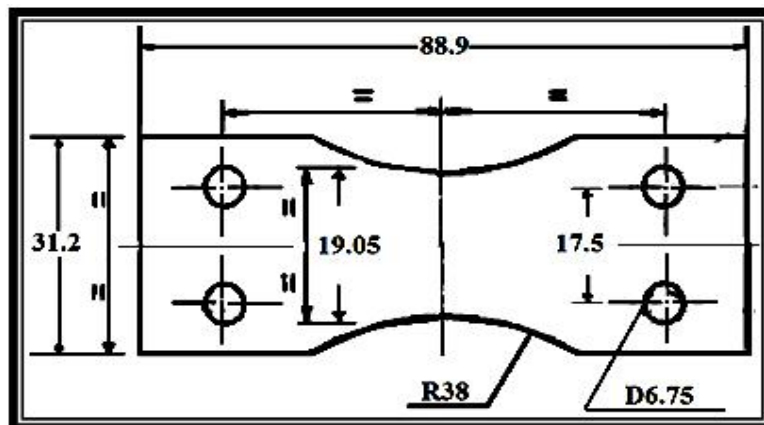

Figure (3) shows drawing detail of specimen.

The crack propagation was deduced from the evolution to the final failure stage. The data on crack lengths with number of cycles were taken and used to calculate the average of crack growth to get the mathematical equation of long cracks, and estimate the age of these parts, by using set of equations, in the discussion of the results in this study.



Figure (4) shows the machine of fatigue test.

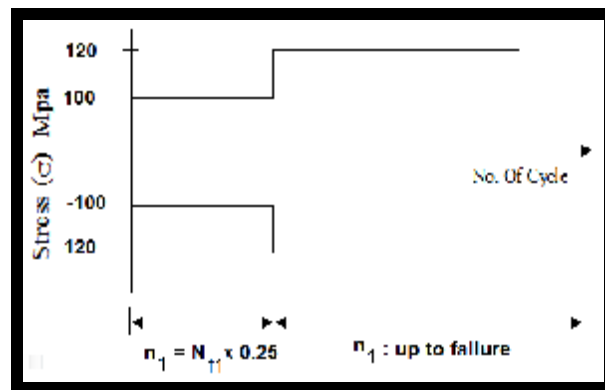

Figure (5) shows Variable fatigue loading.

## RESULTS AND DISCUSSION

The relationship between stress and the number of cycles to failure (fatigue life) as S-N curve was showed in Figure (6). The figure showed a three types of curves; curve of the base material, curve of the welded specimen by tool type A and curve of the welded specimen by tool type B.

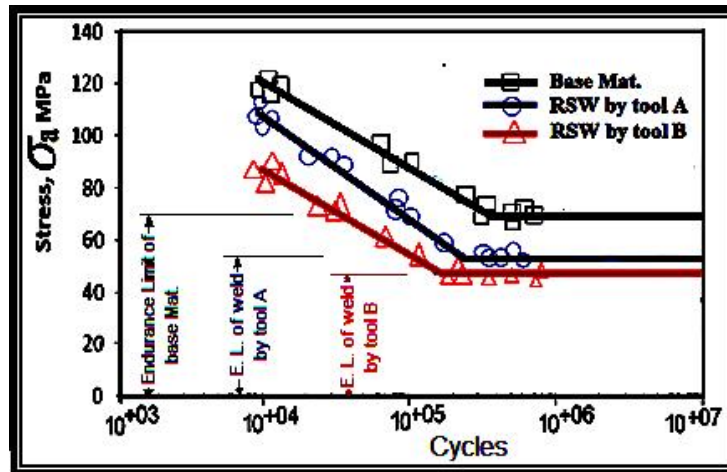

Figure (6) shows life comparison between base metal and RSW.

From the first curve, it is observed that at an alternating stress level of 120 MP<sub>a</sub>, the number of cycles to failure is 10<sup>+4</sup> whereas, at alternating stress of 90 MP<sub>a</sub>, the number of cycles to failure is increased to 10<sup>+5</sup>. This linear relationship between applied stress and the number of cycles to failure is valid up to applied stress of 75 MP<sub>a</sub>, not more than. After applied stress of 75 MP<sub>a</sub>, the base material withstand an infinite number of cycles. This behavior of base material coincides to general behavior of Mild steel. The applied stress of 75 MP<sub>a</sub> called the endurance limit.

The stress level at which the material can withstand an infinite number of cycles is called the Endurance Limit [8]. This is a mechanical fact that explains the constant relationship between stress and the number of cycles to failure, which is shown as a horizontal line in Figure (6).

The second curve in Figure (6) showed the fatigue behavior of the welded specimen by tool type A. It is observed that at an alternating stress level of 110 MP<sub>a</sub>, the number of cycles to failure is 10<sup>+4</sup> whereas, at alternating stress of 70 MP<sub>a</sub>, the number of cycles to failure is increased to 10<sup>+5</sup>. This linear relationship between applied stress and the number of cycles to failure is valid up to applied stress of 50 MP<sub>a</sub>. After applied stress of 50 MP<sub>a</sub>, the welded specimens withstand an infinite number of cycles, it is the endurance limit of the welded specimen by tool type A. As observed resultant; the fatigue life of the welded specimen by tool type A is equal to about 70% of the fatigue life of the base material.

The third curve in Figure (6) showed the fatigue behavior of the welded specimen by tool type B. It is observed that at an alternating stress level of 82 MP<sub>a</sub>, the number of cycles to failure is 10<sup>+4</sup> whereas, at alternating stress of 55 MP<sub>a</sub>, the number of cycles to failure is increased to 10<sup>+5</sup>. This linear relationship between applied stress and the number of cycles to failure is valid up to applied stress of 40 MP<sub>a</sub>. After applied stress of 40 MP<sub>a</sub>, the welded specimens withstand an infinite number of cycles, it is the endurance limit of the welded specimen by tool type B. As observed resultant; the fatigue life of the welded specimen by tool type B is equal to about 70% of the fatigue life of the welded specimen by tool type B, in heavy load and about 90% in Endurance region. That means; the increment was 30% in heavy loads and

10% in low loads based on tool geometry. The improvement in the fatigue life was produced by reducing the diameter of the nose in the geometry of the tool.

The fatigue crack growth, as a function of number of cycles is shown in Figure (7). In this figure we can note that the fatigue crack length depends fundamentally on the tensile strength of the material. This behavior can be explained as a function of the plastic zone formation (ductility), that formed around the crack tip which tends to be larger in the base metal than in the welded metal. This plastic zone is promoted by the loss of hardening in the welded joint due to the micro structural transformation of fine precipitates with small flake shape of mild. Thus, when the crack reaches a critical size, it tends to propagate very quickly in a similar manner.

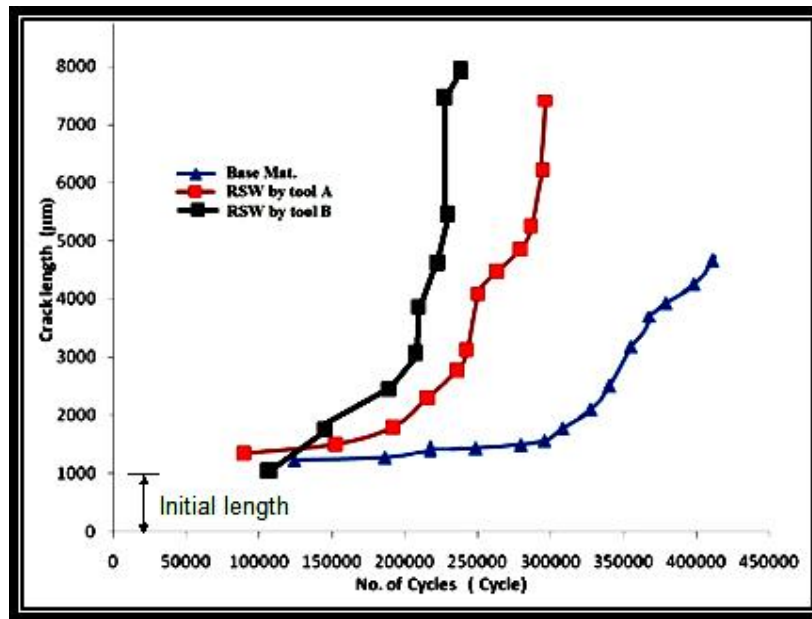

Figure (7) Relationship between crack length and cycles.

The experimental data of  $da/dN$  versus  $\Delta K$  are shown in Figure (8). The crack growth rate  $da/dn$  is the ratio between the variation in crack length ( $da$ ) to the variation in number of cycles ( $dn$ ):

$$\frac{da}{dn} = \frac{a_{i-1} - a_i}{n_{i-1} - n_i} \dots \dots \dots (1)$$

The average crack length is computed as follows:

$$a_{avg} = \frac{a_{i-1} + a_i}{2} \dots \dots \dots (2)$$

Paris law is not suitable for determining crack growth rate for short cracks. Therefore, for long cracks Paris law is used to determine the crack growth rate to predict fatigue life accurately as follows [9]:

$$\frac{d_a}{d_n} = C (\Delta K)^m \dots (3)$$

where:  $\Delta k = \Delta S \sqrt{pa}$ , or  $k = S \sqrt{pa}$ ,  $da/dn$  = crack growth rate,  $K$  = stress intensity factor,  $\sigma$  = applied stress and  $a$  = crack length.

Paris law represents a good relationship between crack growth rate ( $da/dn$ ) and stress intensity factor range ( $\Delta K$ ).

The results of Figure (7) were fitted according to the Paris law, as equation (3), where  $C$  and  $m$  are experimentally obtained from fitting curve.

From Figure (8), an important difference between  $da/dN$  versus  $\Delta K$  behavior can be seen. And this means that the crack growth behavior is divided by a critical stress intensity factor,  $\Delta K_{crit} \approx 10 \text{ MPa}\cdot\sqrt{\text{m}}$  for base metal and  $7 \text{ MPa}\cdot\sqrt{\text{m}}$  for FSW.

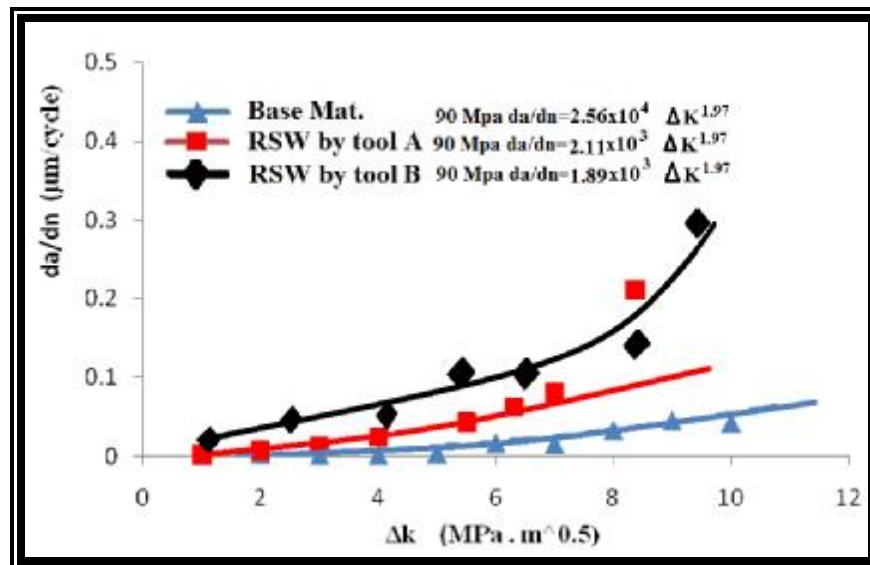

Figure (8) shows the Crack growth rate for base metal and RSW.

Nevertheless, when  $\Delta K_{crit} > 10 \text{ MPa}\cdot\sqrt{\text{m}}$  the faster crack growth corresponds to the base metal. In contrast, when  $\Delta K_{crit} < 10 \text{ MPa}\cdot\sqrt{\text{m}}$  the crack growth in the base metal is the slowest. Also, the same behavior obtained for friction stir weld, but at critical stress intensity factor  $7 \text{ MPa}\cdot\sqrt{\text{m}}$ . Figure (9), shows the relationship between  $n/N_f$  vs. crack length for the base metal and RSW, can be seen a similar behavior for both, because of the converge of grain size and similarity of crack propagation behavior until failure.



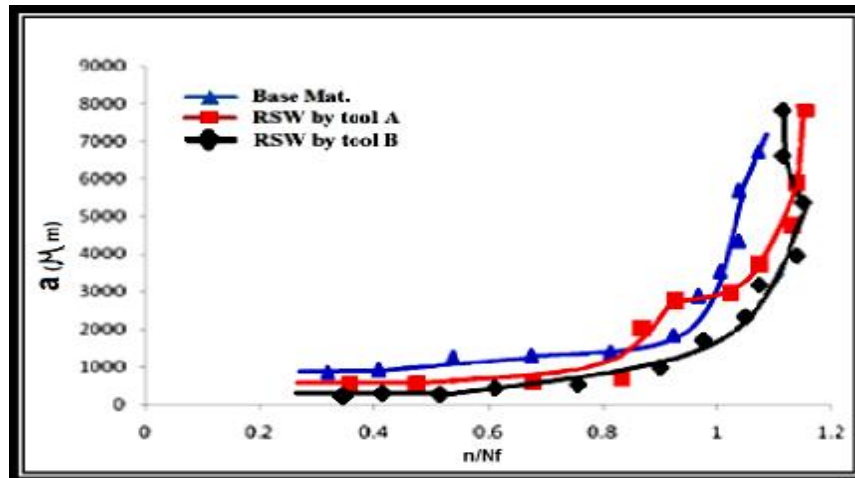

Figure (9) shows  $n/N_f$  vs. crack length for base metal and RSW.

### CONCLUSIONS

- (1) The geometry of the tool is an important parameter in the resistance spot welding, especially the nose of the electrode.
- (2) The reducing of 20% in the diameter of the nose in the tool, caused an improvement in the fatigue life about 10-30%.

### REFERENCES

- [1]. Kang, H., Barkey, M. E., and Lee, Y. "Evaluation of Multiaxial Spot Weld Fatigue Parameters for Proportional Loading", *Int. J. Fatigue* 22, pp. 691-702, 2000.
- [2]. Bonnen, J., Agrawal, H., Amaya, M., Iyengar, R., Kang, H., Khosravaneh, A.K., Link, T., Shih, M., Walp, M., and Yan, B. "Fatigue of Advanced High Strength Steel Spot Welds", *SAE 2006 Transactions Journal of Materials & Manufacturing*, 2006-01-0978. (2007)
- [3]. Kang, H., Iyengar, R., and Bonnen, J., "Variability of Fatigue Strength of Spot Welded Specimens for Advanced and Traditional High Strength Steels", *MS&T 2007*, September 16~20, Detroit, MI. (2007).
- [4]. Hong-Tae Kang, Ilaria Accorsi, Bipin Patel, Eric Pakalns, "Fatigue performance of resistance spot welds in three sheet stack-ups" *Procedia Engineering* 2, p.129-138, (2010).
- [5]. Tran, V.-X. J. Pan, "Effects of weld geometry and sheet thickness on stress intensity factor solutions for spot and spot friction welds in lap-shear specimens of similar and dissimilar materials", *Engineering Fracture Mechanics* (77) 1417-1438, (2010).
- [6]. Lin, P.-C. D.-A. Wang, J. Pan, "Mode I stress intensity factor solutions for spot welds in lap-shear specimens", *International Journal of Solids and Structures* 44, p.1013-1037, (2007).
- [7]. Rathbun, R.W., Matlock, D.K., and Speer, J.G., "Fatigue Behavior of Spot Welded High-Strength Sheet Steels", *Welding Journal*, 207-S ~ 218-S, (2003).
- [8]. Marten, "Fatigue", lecture, Massachusetts Institute of Technology, (2005).
- [9]. Fuad M. Hassan, "Corrosion fatigue behaviour of nitrided low alloy steel compared to austenitic stainless steel", PhD Thesis, University of Technology, 1995.