

Improvement of the Strength of Spot Welding Joint for Aluminum Plates Using Powders as Additive

Dr. Moneer H. Al-Saadi

Technical College, Foundation of Technical/Baghdad

Email: monerht@yahoo.com

Dr. Sabah Khammass Hussein

Technical College, Foundation of Technical/Baghdad

Received on: 18/10/2012 & Accepted on: 7/3/2013

ABSTRACT

This research is interest in increasing the strength of spot welding joint for thin commercial Aluminum by adding casting component to the welding zone in the form of powder. Those components are copper, manganese and magnesium which are added in a different percentages it appear that the strength of the spot welding has been improved by (14.5%) when adding (0.4 grams of magnesium), (0.1 grams of manganese) and (0.4 gram of copper).

The powder is added in the welding zone boundary after made a single hole with a depth of (0.375mm) and a diameter of (1mm) in the center of spot welding point.

To increase the welding strength, five holes have been made with the same above dimensions through the welding zone boundary. The percentages of additive used after reparation the reduction of Aluminum powder.

The value of shearing strength increase with a percentage of (27.3%) as comparing with those without additive.

Also, heat treatment has been done, which gave a redaction in the strength of spot welding. It has been observed that the increase in the temperature of heat treatment result in decreasing in the spot strength. Welding and cooling environment have an effect on the strength of welded specimen. Hence, air welding environment gives a good welding strength.

Keywords: resistance spot welding, spot welding shear, powder additive.

تحسين مقاومة وصلات اللحام النقطي لصفائح الألمنيوم باستخدام المساحيق كمضاف

الخلاصة

يهتم العمل الحالي بزيادة متانة وصلة لحام النقطة لصفائح الألمنيوم التجاري من إضافة عناصر سبائكية الى منطقة اللحام وعلى شكل مساحيق وتمثلت هذه العناصر بالنحاس والمغنيسيوم والمنغنيز وبنسب متفاوتة ، حيث تم ملاحظة تحسن متانة القص بمقدار (14.5%) بإضافة العناصر: (0,4 غرام) مغنيسيوم و (0,1 غرام) منغنيز و (0,4 غرام) نحاس .
إن إضافة المساحيق تمت ضمن حدود منطقة اللحام وذلك بعد عمل فجوة مصطنعة واحده بعمق (0,375 ملم) وبقطر (1 ملم) في منتصف منطقة اللحام .

ومن أجل تحسين متانة اللحام فقد تم تثقيب خمس فجوات بنفس القياسات اعلاه ضمن منطقة اللحام وبنفس النسب اعلاه بعد تعويض النقص الحاصل بمسحوق الألمنيوم وقد تحسنت قيمة مقاومة القص بحدود (27,3%) مقارنة مع متانة القص لنقطة الملحومة بدون المضافات. كذلك أجرينا معاملة حرارية، حيث أعطت نقصانا " بمقاومة اللحام. حيث لوحظ أن زيادة درجة حرارة المعاملة الحرارية تعطي نقصان في بمقاومة اللحام. بيئة اللحام والتبريد لهما تأثير على مقاومة الملحومات، حيث بيئة الهواء تعطي أحسن مقاومة لحام.

INTRODUCTION

In resistance spot welding overlapping sheets of metal are joined by applying electric current and pressure in the zone to weld with copper electrodes. Copper is used for electrodes because it has low electrical resistance and high thermal conductivity. Spot welding operation is composed of three steps that are the squeezing, welding and holding stages.

Squeezing consists of applying the weld force to the work-pieces in order to obtain the appropriate amount of pressure, prior to welding. During welding, the electric current passes through the work-pieces, while the welding force is maintained, generating heat [1].

The behavior of resistance spot welded joint was studied under tensile-shear and coach-peel loading condition [2]. Failure modes of resistance spot welds, pullout and interfacial, were investigated based on experimental observation. Results showed that there is a critical fusion zone size to ensure pullout failure mode. The experimental results showed that in pullout failure mode during shear-tensile test, necking is initiated at nugget circumference in the base metal and then the failure propagates along the nugget circumference in the sheet to final fracture.

Increasing the use of aluminum sheet replacing steel in order to reduce weight calls for improved understanding and control of aluminum spot welds, which present more problems than spot welding of steel. This is due to aluminum's higher electrical and thermal conductivity, higher coefficient of expansion, lower melting temperature and an oxide film, which has high electrical resistance and high melting temperature. The latter together with the fact that the effective contact resistance grows considerably as the oxide film grows implies large scatter in quality of RSW aluminum sheets, which therefore require close production control [3, 4&5].

Recent study proposing a new approach in (Resistance Spot Welding) RSW aluminum sheets by adding a small amount of a specific metallic powder between the faying surfaces to increase the electrical contact resistance, which in turn increases the heat generated and improves the weld strength. Comparison is made between normal RSW and RSW with metallic powder additives in joining aluminum AA1050 studying weld strength, hardness distribution and macro- and micrographs of the welds[6].

The high thermal and electrical conductivity of aluminum require 2-3 times higher current and shorter weld time, typically 25% of that used to (Resistance Spot Welding) RSW steel. Accurate control and synchronization of current and electrode force is required due to the narrow weld temperature range [7].

EXPERIMENTAL WORK

Preparation the standard spot welding specimen

In this work, the specimens have been made from a sheet of commercial Aluminum with a thickness of (1mm) .This sheet cut into a number of pieces in the rolling direction with the following dimensions ,Figure (1), :-
Thickness=1mm; width=25.4mm and the length=101.6mm.

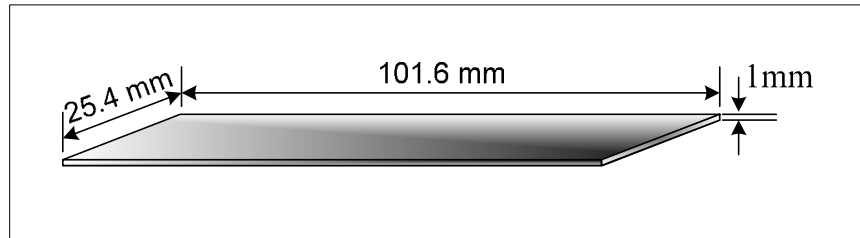

Figure (1) standard spot welding piece.

The material specification of Aluminum is listed in Table (1) below:

Table (1) chemical and mechanical properties of Aluminum.

Chemical composition (wt%)					Mechanical properties		
Si	Mn	Fe	Others	Al	Trade name	Tensile strength(MPa)	Hardness(HV)
0.100	0.018	0.378	0.004	99.5	1050	105	30

Overlapping sheet metal of Aluminum specimen gives a common area has the following dimensions: (25.4*25.4 mm²), Figure (2). They were ready to weld as a lap joint and subsequent tensile shear force test.

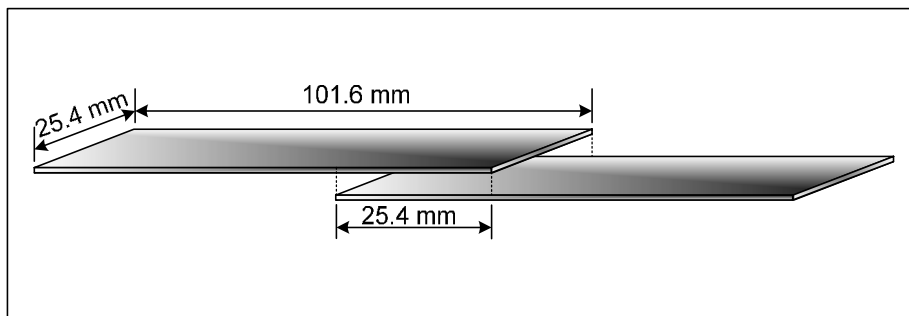
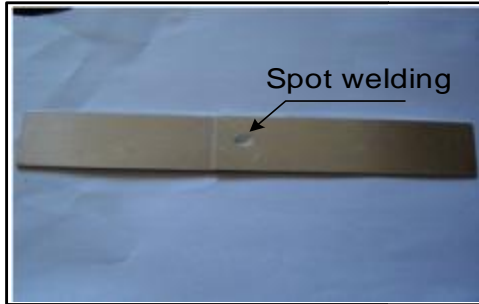

Figure (2) overlapping the two pieces of spot welding specimen.

The spot weld lies in the center of this area. The cross of two cord draw in this area gives the point of spot welding, see Figure (3).



(a) Welded specimen



(b) Specimen prepared to weld

Figure (3) photography of Aluminum specimens.

WELDING MACHINE

A digital input data welding machine of type (SIP Column-PPV50) is used to perform the spot welding operation. This machine includes a wide range of variables used in this search, (squeeze time, welding time, hold time, current and pressure).

Figure (4) represents the photograph picture of spot welding machine. The general specifications of this machine are listed in Table (2).

Table (2) Specifications of resistance spot welding machine.

Controller	Max. power	Frequency	Max. welding force	Supply pressure	Throat depth	Phases	Electrode force per (1bar)
CSW-0.2, 7functions	90 KVA	50 Hz	2.7 KN	3-9 bar	150-440 mm	1	0.3 KN



Figure (4) photography of spot welding equipment.

WELDED SPECIMEN

An adequacy number of specimens have been welded with different variables in the welding machine to distinguish the optimum value of the shearing force for the spot welding .The variables which gives the optimum value will be considered as the best conditions for this type of Aluminum.

The welded specimens are classified into groups listed in Tables (3-8), in each group; the following parameters are constant during the welding operation:

Squeeze time=0.9898 sec.

Hold time=0.3959 sec.

Pressure=50 Psi.

Table (3) variation of shear force with the welding time for the first group, current=1250 Amp.

Specimen number	Welding time (sec.)	Shear force(N)
5	0.989 (failed)	-
6	0.515	80
7	0.713	381.6
8	0.910	197.8

Table (4) variation of shear force with the welding time for the second group, current=1319 Amp.

Specimen number	Welding time (sec.)	Shear force(N)
9	0.515	93.54
10	0.594	303.2
11	0.713	320.6
12	0.792	131.7

Table (5) variation of shear force with the welding time for the third group , current=1387 Amp.

Specimen number	Welding time (sec.)	Shear force(N)
13	0.515	76.4
14	0.594	293.8
15	0.713	199.5
16	0.792	470.9

Table (6) variation of shear force with the welding time for the fourth group , current=1455 Amp.

Specimen number	Welding time (sec.)	Shear force(N)
17	0.515	322
18	0.594	317
19	0.713	542.6
20	0.792	266.2

Table (7) variation of shear force with the welding time for the fifth group , current=1523 Amp.

Specimen number	Welding time (sec.)	Shear force(N)
21	0.515	125.7
22	0.594	353
23	0.713(failed)	-
24	0.792	165.2

Table (8) variation of shear force with the welding time for the sixth group , current=1659 Amp.

Specimen number	Welding time (sec.)	Shear force(N)
25	0.515	458.9
26	0.594(failed)	-
27	0.713	360.4
28	0.792	494.4

IMPROVING THE WELDING TOUGHNESS

The welding toughness represents the shearing force of the spot welding. In this research, the improving has been done by adding some of chemical powder components with different ratio on the Aluminum specimen at the region of welding.

The powder is added on the gap leis at the center of the common area for the two pieces of Aluminum specimen before the welding operation.

THE DIE USED TO FABRICATE GAP

This die consist of two pieces and has been manufactured by (computer- numerical-control machine, CNC-machine) in (Technical college– Baghdad), the first one represent a stainless steel piston with outcrop at the end of this piston have the following dimensions:

Diameter=1mm; height =1mm.

Therefore; the diameter here represents the diameter of gap with a height (0.375 mm) in the specimen of Aluminum.

This piston is inserted inside the second pieces of die (copper bush). The external diameter of the piston is equal to the internal diameter of bush with a suitable tolerance so as to move the piston through the bush without friction. Figure (5) shows the schematic and photographic picture of this die

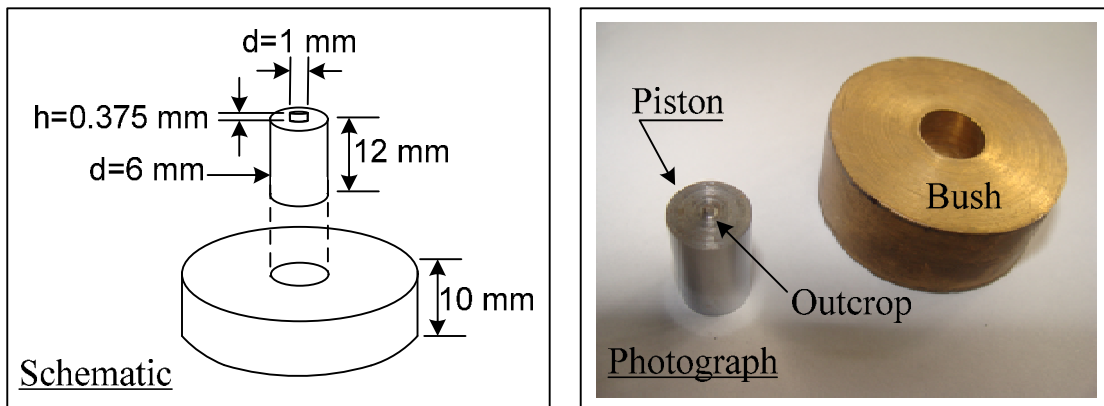
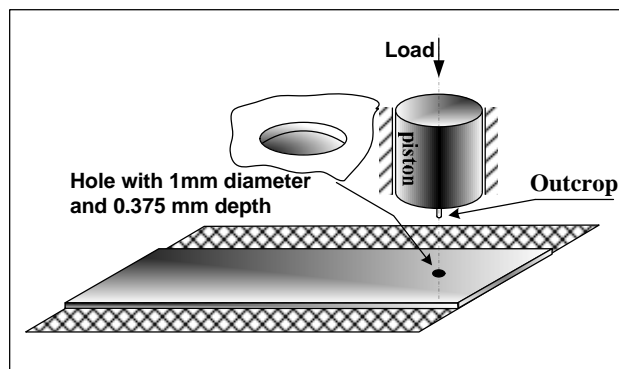

Figure (5) schematic and photography of gap die.

THE MECHANISM OF MAKE GAP IN THE ALUMINUM SPECIMEN

A pressing machine is used to apply a compressive force (300N) on the piston which has a diameter of (6 mm), Figure (5), and slide through the bush. This mechanism will compress the sample of Aluminum by outcrop to make a gap with diameter ($d=1\text{mm}$) and height ($h=0.375\text{mm}$) which is the same outcrop dimensions, Figure (5). The operation is done such that the center of the piston circle is the same as the center of the common area which represent the center of spot welding, Figure (6).

Hence, the gap depth (0.375 mm) in Aluminum specimen represents the outcrop depth (0.375 mm).



Figure(6) schematic diagram of making gap mechanism.

THE POWDER OF CHEMICAL ADDITIVE COMPONENT

Three chemical components are used in the form of powder. Those components are mixed with suitable percentage to full the gap made in section 2.3.2. The mixing process is done using ball mill (Department of Production Eng. & metallurgy / University of technology) to achieve the following purpose [8]:

- Obtain a uniform distribution of powder

- Better control of subsequent pressing resulted from the electrode of spot welding machine.

The powder components are of (manganese, magnesium and copper) with grain size listed in Table (9).

Table (9) grain size of powder (mm).

Cu	Mg	Mn
30-80	100	1-2

Four groups of those powder alloys are prepared. Table (10) gives those percentages as follows:

Table (10) weights and percentages of the chemical additive.

Alloy	Mn		Mg		Cu		Total weight (grams)	Shear force(N)
	w (grams)	w %	w (grams)	w%	w (grams)	w%		
A	0.1	14.23	0.2	28.23	0.4	57.14	0.7	522.5
B	0.2	25	0.2	25	0.4	50	0.8	573
C	0.1	11.11	0.4	44.44	0.4	44.44	0.9	620
D	0.2	20	0.4	40	0.4	40	1.0	513

For each of the above groups, the powder of components is mixed uniformly until the visible homogeneity is occurred. The alloy of chemical powder component is added on the Aluminum specimen gap and the other pieces of Aluminum are put on these which contain gap. Hence, the final will be ready to welding.

According to the above procedure, four specimens are prepared. Each of those specimen contain one type of Alloy (A, B, C or D), Table (10).

The shear forces values in Table (10) are found from the tensile test which represents the failure force in each specimen in this test.

RESULTS

Tensile test

To inspect the optimum condition for the welded Aluminum in the above groups, the tensile test has been done and the value of shearing force for the spot welding can be evaluated.

A digital tensile test equipment used to input and output data in the aid of computer with a higher accuracy which connected with equipment, Figure (7).



Figure (7) photography of tensile test machine.

It's observed that the values of shearing force for specimens without additive limited from (76.4N) as a minimum value in group (3) to (542.6N) as a maximum value in group (4), see Tables (3-8). As a result, the optimum condition for welding this type of Aluminum is found in group (4) at the current (1455 Amp.), in which, the shear force is equal to ($F=542.6\text{ N}$) will be considered as a reference to improve the welding shearing force.

Figures (8, 9 and 10) show the variation of the shearing force of the welded specimen through the welding parameter. Hence the maximum and minimum shearing force appeared in the above figures.

It has been observed in group (1&2) that the strength of spot welding increase gradually during welding time until reach its maximum values at (welding time ≈ 0.7 sec.) and then decrease, Figure(8).

In group (3&4), an alternating welding strength has been observed during welding time, Figure (9). This is due to the non coincidence between this time and the input welding heat.

In group (5), the welding strength is increased gradually and then decreased, but in the other group (6) this strength decreased gradually and then increased during welding time.

Aluminums spot welding contain a complex mechanisms of expulsion which involving electrical, thermal, metallurgical, and mechanical processes. These mechanisms gave an alternating in the strength of spot welding as shown in Figures (8, 9 &10)

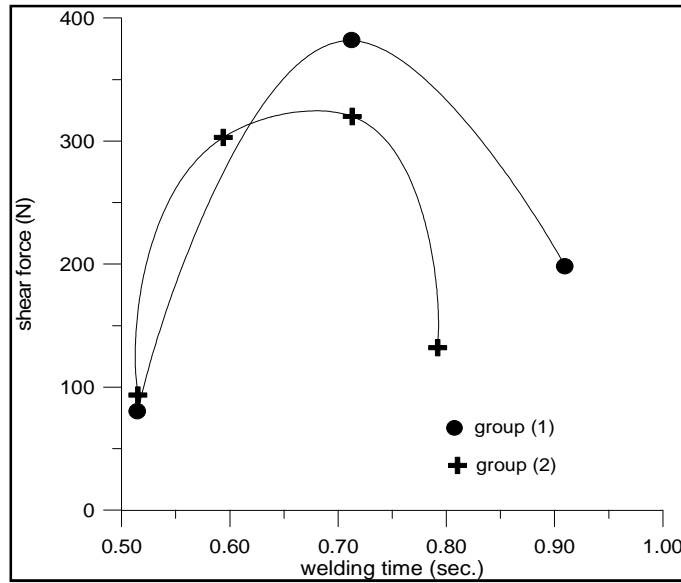

Figure (8) variation of shear force with the welding time (groups 1,2).

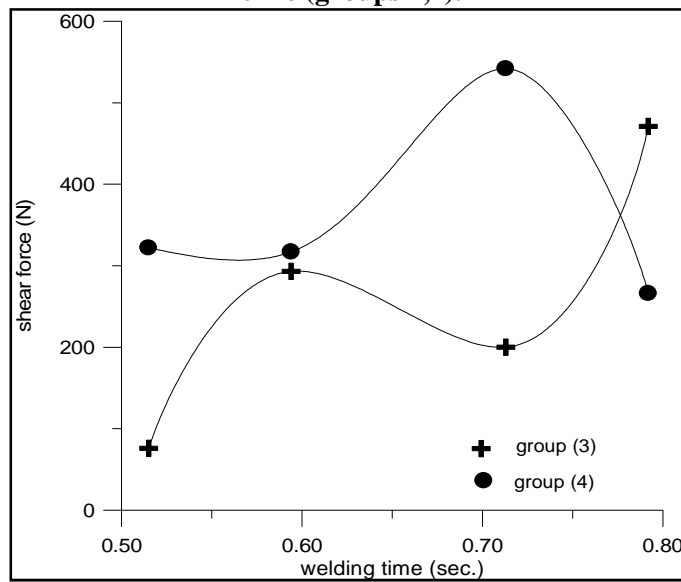

Figure (9) variation of shear force with the welding Time (groups3, 4).

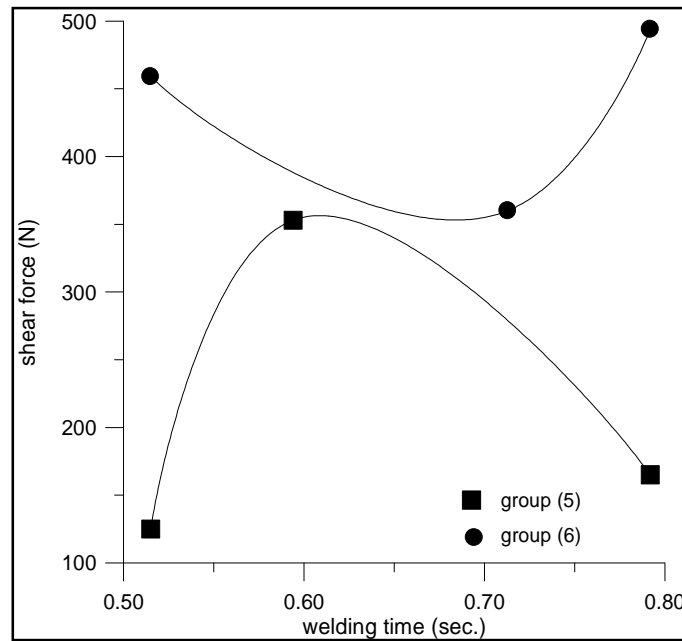

Figure (10) variation of shear force with the welding time (groups 5,6).

Improvement the toughness of spot welding using a single gap, Figure (3)

The prepared specimens in section (2.3.3) are welded according to the optimum condition mention in section (3.1) so as to improve the toughness of spot welding.

Each specimen tested under the tensile test equipment. Specimen of type (c) gives a maximum shear force value which is equal to (620 N) as comparing with that of (F=542.6 N) in specimen (19) in Table (6), and so, the toughness of welding is improved with a percentage of (14.5 %). That means increasing the weight of magnesium and decreasing the weight of manganese give a good welding strength.

Improvement the toughness of spot welding using a uniform engineering shape of gaps arrangement

Five gaps are arranged in a uniform engineering shape of the Aluminum pieces as shown in Figure (11), an alloy of type (C) is added to those gaps after it mixed with the Aluminum powder so as to repayment the reduction in Aluminum that occurred from gap.

Hence, the origin Alloy of each gap will be containing a (20%) from the total volume and (80%) from the powder of Aluminum Table (11).

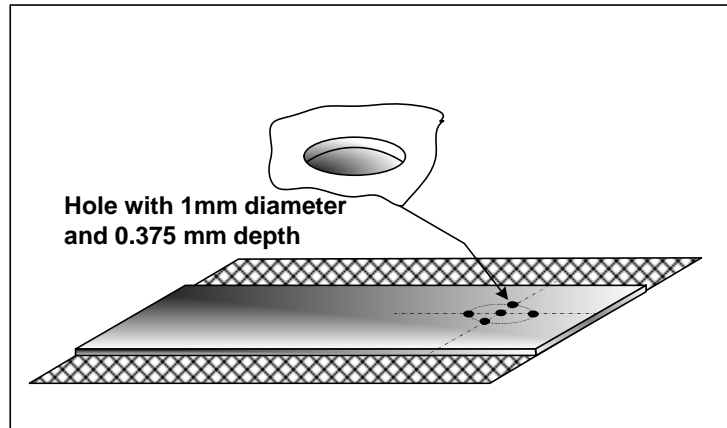

Figure (11) schematic diagram of gap arrangement.

Table (11) the percentage of chemical component for alloy (c) and Aluminum.

Aluminum%	Alloy (C)			Shear force (N)
	Mn(%)	Mg (%)	Cu (%)	
80	2.22222	8.88888	8.88888	690

Group (C) is used here which represent the optimum toughness of spot welding. The value of shearing force is recoded from the tensile test and equal to (690 N). As a result, the percentage of increasing toughness will be (27.3%). This result may be considered as a good value as comparing with that of (14.5%).

The higher strength improvement obtained with pure aluminum powder is probably due to defects in the weld caused by non-fusion grains of copper and manganese with high melting temperature.

Figure (12) shows the base metal, HAZ and the welding zone for the improvement specimen (27.3%).



(a) Base metal (b) Heat affected zone (c) Weld metal

Figure (12)The base metal, HAZ and the welding zone for the improvement specimen (27.3%)

The effect of heat treatment on the shear strength of weldment

Heat treatment is done on the specimen type “c” for three different temperatures (400,425 and 450 °C) with interval time (25 minutes) for each temperature. It observed that heat treatment gives a decreasing in the strength of spot welding especially at (T=425 °C) , in which the shear force decreased to (320 N).

Table (12) represents these values of shear forces with the heated temperature of specimen.

Table (12) variation of shear forces with the heat treatment temperature.

Heat treatment temperature (°C)	Heat treatment time (minute)	Shear force (N)
400	25	590
425	25	320
450	25	480

The effect of welding and cooling surroundings on the strength of spot welding

Two types of welding surroundings have been used during the welding process (air & argon). The welded specimen is cooled in two different cooling surroundings (air & water) which give an effect on the property of the strength of weldment as follows:

1. Surrounding type air:

Type “c” of weldment specimen is welded under the condition of air surrounding and cooled in air which gives a shear force of (620 N) while the shear force reduced to (535 N) when the specimen cooled in water .

2. Surrounding type argon:

Type “c” of weldment specimen is welded under the condition of argon surrounding and cooled in air which gives a shear force of (480 N) while the shear force reduced to (534 N) when the specimen cooled in water .

Table (13) represents those results:

Table (13) variation of shear forces with the welding and cooling surroundings.

alloy	cooling	Welding environment	Shear force (N)
c	air	air	620
c	water	air	535
c	air	argon	480
c	water	argon	534

CONCLUSIONS

The experimental strength of spot welding joint is studied in this work with the following conclusions:

- 1- The shear force of spot welding is affected by the welding time and the electrical current of resistance spot welding machine
- 2- The maximum shear force is obtained in specimen with welding time (0.594 sec.) and current (1455 Amp.).
- 3- Addition a chemical powder additive in one hole gives an improvement in shear force with a percentage of (14.3%).
- 4- Addition a chemical powder additive in five holes with an engineering arrangement gives an improvement in shear force with a percentage of (27.3%).
- 5- Heat treatment of welded specimen gives a reduction in the strength of spot weld, hence, increasing the temperature of heat treatment reduce the strength of welded specimen.
- 6- The environment has an effect on the strength of welded specimen. Where, air welding environment gives a good strength than those of argon. Also, cooling surrounding effect depend on the type of welding environment.

REFERENCES

- [1]. Norberto Pires, J. Altino Loureiro and Gunnar Bölmsjö “Welding Robots Technology, System Issues and Applications”, Springer-Verlag London Limited 2006.
- [2]. Pouranvari, M. P. Marashi, M. Goodarzi “failure behavior of low carbon steel resistance spot weld under shear and coach-peel static loading condition”, 13. – 15. 5. 2008, Hradec nad Moravicí, metal 2008.
- [3]. Mathers, G. “The welding of aluminum and its alloys”. Woodhead Publ. Ltd, Cambridge, England. 2002.
- [4]. Newton, C. J., Browne, D. J., Thornton, M. C., Boober, D. R., and Keay, B. F. “The Fundamental of Resistance Spot Welding Aluminum”. Sheet Metal Conference VI, Paper E2, 1994.
- [5]. Senkara, J., and Zhang, H. “Cracking in Spot Welding Aluminum Alloy AA5754. AWS Welding Journal” 79 (7): 194s - 201s, 2000
- [6]. Kim, D. C., Park, H. J., Hwang, I. S., Kang, M. J. RSW of “Aluminum alloy sheet 5J32 Using SCR type and Inverter type Power Supplies”. International Scientific Journal, 38, (1): 55-60, 2009.
- [7]. Resistance Welding Manual, “RWMA Resistance Welding Manufactures Association”, Bridgeport, NG, USA, 2003.
- [8]. Rajput, R.K. “A text book of Manufacturing Mechnology” Laxmi Publications (P) LTD 113, Golden House , Daryaganj, New Delhi-110002, 2008.