

A Simple Hybrid Scheme for Denoising the Medical Ultrasound Images

Nedhal Kareem

Computer Engineering Department, Engineering College, Al- Mustansiriyah University/Baghdad

Yasmin Abdul Ghani

Computer Engineering Department, Engineering College, Al- Mustansiriyah University/Baghdad

Mais Abid Khalil

Computer Engineering Department, Engineering College, Al- Mustansiriyah University/Baghdad

Received On: 3/9/2012 & Accepted On: 10/1/2013

ABSTRACT

The medical ultrasound images are usually corrupted by type of noise called 'speckle'. This noise is caused by the coherent nature of the scattering phenomenon. There are many filters used to reduce the effect of speckle noise like mean, median, Lee, Kaun, Gamma, Weiner, Frost. Recently, One of the most commonly speckle denoising filter is wavelet filter.

In this paper, A simple hybrid scheme is suggested to denoising the ultrasound images. this scheme consist from two interacted filter (winner and mean filter) with window size 3×3 and designed simple adaptive filter(SAF). The adaptation of SAF depends on nonlinear gain function. In order to test the efficiency of the suggested scheme, its performance was compared with performance of other filters like mean, wiener, and wavelet filter.

Keyword: wavelet, speckle, ultrasound images, hybrid filter.

مخطط هجين بسيط لازالة الضوضاء من الاشعة الفوق الصوتية الطبية

الخلاصة

ان الاشعة الفوق الصوتية الطبية تعاني من نوع من الضوضاء يسمى (speckle) ، والذي ينتج بسبب الاستجابة الغير خطية للكاشف والمسجل. هناك الكثير من المرشحات التي النوع من (mean, median, Lee, Gamma, Weiner, Frost). تستخدم لتقليل تأثير هذا احد اكثر المرشحات شيوعا والتي تستخدم لتقليل تأثير (wavelete filter) الضوضاء مثل هذه الضوضاء هوفي هذا البحث تم استخدام مخطط هجين بسيط لازالة الضوضاء من الاشعة مع حجم نافذة 3×3 وتصميم مرشح بسيط (SAF) الفوق الصوتية الطبية والذي يضم نوعان ، والتكيف للنموذج المرشح المقترح يعتمد على دالة الربح الغير خطي . ولغرض اختبار كفاءته اداء مرشحات اخرى مثل (like mean , wiener, and wavelet filter) الاداء ، تم مقارنته مع . من المرشحات (Winner and mean filter).

INTRODUCTION

Now a days an image is synonymous to digital image and is very much essential for daily life applications such as satellite television, medical imaging (magnetic resonance imaging, ultrasound imaging, x-ray imaging), computer tomography. It is also essential for the researches in the areas of science and technology such as geographical information systems and astronomy. The images collected by different type of sensors are generally contaminated by different types of noises [1].

Removing noise from the original image is still a challenging research in image processing. Generally there is no common enhancement approach for noise reduction. Several approaches have been introduced and each has its own assumption, advantages and disadvantages [2].

Image denoising has become very essential in medical image analysis. Almost all medical images, which are acquired using different devices, are affected by a distortion metric, called 'Noise'. Each device introduces different kind of noise. For example, ultrasound images are mostly degraded by 'Speckle Noise'; while X-Ray images are often have 'Poisson noise'. Noise in images, in particular, medical images, have two disadvantages. They are (i) degradation of the image quality and (2) obscuring important information required for accurate diagnosis. As both these points have serious impact, they have to be handled in an efficient manner. Thus, all medical imaging devices need some denoising algorithm to enhance the image under consideration and thus help the medical practitioner to make diagnosis quickly and efficiently [3].

In this paper, a simple hybrid scheme is suggested to reduce the effect of the speckle from the ultrasound images. This scheme consists from two interaction filters (Wiener and mean) and a simple adaptive filter (SAF). This paper is organized as follows: section (2) gives some information about the speckle noise in the ultrasound images, section (3) presents some types of filters which are used to remove the speckle noise. The suggested scheme will be explained in section (4), while the simulation results are presented in section (5). Finally the conclusions are given in section (6).

SPECKLE NOISE WITH ULTRASOUND MEDICAL IMAGES

Ultrasonography is a popular diagnostic tool used for medical investigations. It is noninvasive, cost-effective, accurate and practically harmless to human body [4, 5]. These scans use high frequency sound waves which are emitted from a probe. The echoes that bounce back from structures in the body are shown on a screen. The structures can be much more clearly seen when moving the probe over the body and watching the image on the screen [6]. Unfortunately, ultrasound images are inherently corrupted with speckle noise that makes it difficult to discriminate diagnostically important details such as cysts in breast imagery, and complicates the task of automatic image processing [4, 5].

Speckle noise affects all coherent imaging systems including medical ultrasound. Within each resolution cell a number of elementary scatterers reflect the incident wave towards the sensor. The backscattered coherent waves with different phases undergo a constructive or a destructive interference in a random manner. The acquired image is thus corrupted by a random granular pattern, called speckle that delays the interpretation of the image content [6].

If the multiplicative noise is added in the image, speckle noise is a ubiquitous artifact that limits the interpretation of optical coherence of remote sensing image. The distribution noise can be expressed by[7]:

$$J = I + n * I \quad \dots (1)$$

Where, J is the distribution speckle noise image, I is the input image and n is the uniform noise image by mean μ and variance ν .

SOME TYPES OF SPECKLE FILTERS

There are many filters used to reduce the effect of speckle noise like mean, median, Lee, Kaun, Gamma, Weiner, Frost, wavelet, and so on. In this section, we will explain some types of these filters and as follows:

Mean filter

The Mean Filter is a linear filter which uses a mask over each pixel in the signal. Each of the components of the pixels which fall under the mask are averaged together to form a single pixel. This filter is also called as average filter. The Mean Filter is poor in edge preserving. The Mean filter is defined by [8];

$$\text{Mean filter } (x_1 \dots x_N) = \frac{1}{N} \sum_{i=1}^N x_i \quad \dots (2)$$

Where $(x_1 \dots x_N)$ is the image pixel range.
 N in this scheme is nine pixel.

Median filter

It is defined as the median of all pixels within a local region of an image. It performs much better than arithmetic mean filter in removing salt and pepper noise from an image and in preserving the spatial details contained within the image. This method is particularly effective when the noise pattern consists of strong, spike like components and the characteristic to be preserved is edge sharpness [9].

M3- Filter

The M3-Filter is proposed with hybridization of mean and median filter. This replaces the central pixel by the maximum value of mean and median for each subimages SXY. It is expressed as M3-Filter, the intensity values are reduced in the adjacent pixel and it preserves the high frequency components in image. Therefore it may be suitable for denoising the speckle noise in the ultrasound medical image. It is a simple, intuitive and easy to implement method of *smoothing* images [2].

$$f(x, y) = \max(\underset{(s,t) \in S_{xy}}{\text{median}} \{g(s, t)\}, \underset{(s,t) \in S_{xy}}{\text{mean}} \{g(s, t)\}) \dots (3)$$

Adaptive Wiener Filter

Adaptive Wiener Filter (AWF) changes its behavior based on the statistical characteristics of the image inside the filter window. Adaptive filter performance is usually superior to non-adaptive counterparts. But the improved performance is at the cost of added filter complexity. Mean and variance are two important statistical measures using which adaptive filters can be designed [7].

Wiener filter, also known as least mean filter, is given by the following expression; wiener filter assumes the noise and power spectra of the object a priori. The equations for this filter which are taken from Matlab sources are:

$$b(n_1, n_2) = \mu + \frac{\sigma^2 - v^2}{\sigma^2} (a(n_1, n_2) - \mu) \dots \dots (2.15)$$

$$\mu = \frac{1}{NM} \sum_{n_1, n_2 \in a(n_1, n_2)} \dots \dots (2.16)$$

$$\sigma^2 = \frac{1}{NM} \sum_{n_1, n_2 \in a(n_1, n_2)} - \mu^2 \dots (2.17)$$

Where

$b(n_1, n_2)$ = the undegraded image.

$a(n_1, n_2)$ = the noisy image.

v^2 = is the variance of noise.

μ = mean of image.

Wavelets based noise thresholding algorithm

Speckle noise is a high-frequency component of the image and appears in wavelet coefficients. One widespread method exploited for speckle reduction is wavelet thresholding procedure. The basic Procedure for all thresholding method is as follows[10,11]:

- Calculate the DWT of the image.

- Threshold the wavelet coefficients. (Threshold may be universal or sub band adaptive)
- Compute the IDWT to get the denoised estimate.
- There are two thresholding functions frequently used, i.e. a hard threshold, a soft threshold.

The different methods of wavelet threshold denoising differ only in the selection of the threshold [10].

In this paper, we implement the wavelet filter by using the following soft threshold operator;

$$D(U, T) = \text{sgn}(U(i, j)) * (\max(0, |U(i, j) - T|))^{0.5} \dots (7)$$

Where $\text{sgn}(\cdot)$ is the sign function. And T is Universal thresholding function which is given by:

$$T = \sigma \sqrt{2 * \log(N_i * M_i)} \dots (8)$$

Where $N_i * M_i$ is the size of the subband i . σ is stand deviation of sub band i .

If $|D(U, T)| > T$, then $\hat{D}(U, T) = D(U, T)$, else $\hat{D}(U, T) = 0$

THE SUGGESTED HYBRID SCHEME

The block diagram for the suggested hybrid scheme is shown in Figure(1),

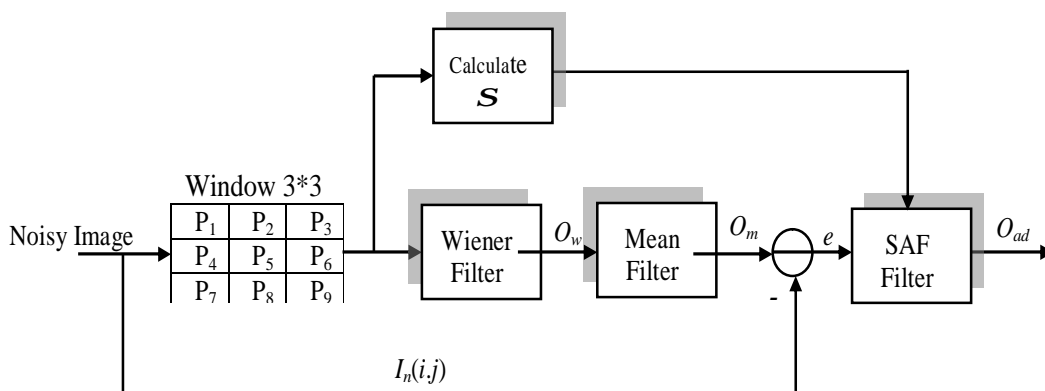

Figure (1) the block diagram for the suggested hybrid scheme.

The operation of the overall hybrid scheme can be explained as follows:

- 1- the wiener and mean filter working in interaction manner, each filter work on window size 3*3.
- 2-the difference (error signal) between the current noisy pixel $I_n(i,j)$ and the current estimated pixel(the output of the mean filter) $O_m(i,j)$, i.e the error signal will by;

$$e(i,j) = I_n(i,j) - O_m(i,j) \quad \dots(9)$$

- 3-the stander devition (S) is calculated for window size 3*3 as shown in Figure (1).

- 4- the simple adaptive filter (SAF) consist from two steps:

i- calculate the gain function by using the following design function;

$$K(i, j) = 1 - \exp\left(\frac{-a * |e(i, j)|}{bS}\right) \quad \dots (10)$$

Where a, b are positive design parameters (less than one).

*ii-*the estimated pixel by SAF is calculated by:

$$O_{ad}(i, j) = O_m(i, j) + K(i, j) * (I_n(i, j) - O_m(i, j)) \quad \dots (11)$$

EXPERIMENTAL RESULTS AND DISSECTION

Kidney ultrasound image (Figure(2-a)) is tested in this section under different speckle noise variance using the suggested scheme in addition to other filters like mean, median, m3, wiener, and wavelet filter to show the efficiency of the suggested filter. The performance of each filter is tested using the following:

1-sinal to noise ratio (SNR): the signal -to noise ratio (SNR) for the corrupted image is calculated by [12];

$$SNR = 10 \log_{10} \frac{\sum X^2(i, j)}{\sum V^2(i, j)} \quad \dots (12)$$

With $X(i,j)$ and $V(i,j)$ denoting the values of the original image and the observation noise respectively.

The signal-noise ratio of the restored images is computed as follows,[12],

$$SNR = 10 \log_{10} \frac{\sum X^2(i, j)}{\sum (X(i, j) - \hat{X}(i, j))^2} \dots (13)$$

where $\hat{X}(i, j)$ denotes the value of the restored images.

2- Mean squared error (MSE): The denoising images can be also evaluated by the MSE [10],

$$MSE = \frac{1}{MN} \sum_{i=1}^M \sum_{j=1}^N X(i, j) - Y(i, j))^2 \dots (14)$$

3- Image quality image index: this index $|Q|$ [13] is used to judging the quality of denoised images;

$$Q = \frac{4s_{fg} \bar{f}\bar{g}}{(s_f^2 + s_g^2)(\bar{f}^2 + \bar{g}^2)} \dots(15)$$

Where

$$\bar{f} = \frac{1}{M} \sum_{i=1}^M f_i \qquad \bar{g} = \frac{1}{M} \sum_{i=1}^M g_i$$

$$s_{fg} = \frac{1}{M-1} \sum_{i=1}^M (f_i - \bar{f})(g_i - \bar{g})$$

s_f^2 and s_g^2 are the variance of the denoised image f and the original image g respectively. A kidney noisy image (with speckle noise variance=0.3) is shown in Figure(2-b), and The denoised images by the different tested filters are shown if Figure(2-c) to Figure(2-h).

also, The SNR, MSE, and the index $|Q|$ for the different tested filters under different speckle noise variance are presented by Table(1), Table(2), and Table(3)

Table (1) the SNR for the tested filters under different variance.

variance	Noisy image	mean	median	M3	wiener	Hybrid scheme	wavelet
0.1	11.0327	10.0096	9.3766	10.1295	13.2475	11.2772	11.4493
0.2	8.1801	9.4711	8.5055	9.4801	10.6577	10.5493	10.0003
0.3	6.4252	8.9006	7.7661	8.9359	8.9478	9.7938	9.0145
0.4	5.3405	8.5097	7.2145	8.4999	7.9589	9.2997	8.2862
0.5	4.6144	8.1927	6.7424	8.1321	7.2807	8.9041	7.7888
0.6	4.0753	7.9479	6.3211	7.8194	6.8194	8.6401	7.4318
0.7	3.6686	7.7608	6.0278	7.5946	6.4751	8.4058	7.0927
0.8	3.3543	7.6044	5.7747	7.3974	6.2193	8.2373	6.8862
0.9	3.1045	7.4738	5.5290	7.2029	6.0726	8.1080	6.6714
1	2.8260	7.3174	5.2037	6.9829	5.8359	7.9466	6.4936

Table (2) the RMS for the tested filters under different variance.

variance	Noisy image	mean	median	M3	wiener	Hybrid scheme	wavelet
0.1	0.0054	0.0228	0.0080	0.0067	0.0033	0.0051	0.0049
0.2	0.0105	0.0272	0.0097	0.0077	0.0059	0.0061	0.0069
0.3	0.0157	0.0319	0.0115	0.0088	0.0088	0.0072	0.0086
0.4	0.0201	0.0359	0.0131	0.0098	0.0110	0.0081	0.0102
0.5	0.0238	0.0396	0.0146	0.0106	0.0129	0.0089	0.0115
0.6	0.0270	0.0432	0.0161	0.0112	0.0143	0.0094	0.0124
0.7	0.0296	0.0459	0.0172	0.0117	0.0155	0.0099	0.0135
0.8	0.0318	0.0484	0.0182	0.0126	0.0165	0.0103	0.0141
0.9	0.0337	0.0509	0.0193	0.0132	0.0170	0.0106	0.0148
1	0.0359	0.0543	0.0208	0.0137	0.0180	0.0111	0.0154

Table (3) the index $|Q|$ for the tested filters under different variance.

variance	mean	median	M3	wiener	Hybrid scheme	wavelet
0.1	0.9686	0.9751	0.9835	0.9949	0.9709	0.9895
0.2	0.9625	0.9753	0.9837	0.9948	0.9645	0.9847
0.3	0.9528	0.9722	0.9813	0.9939	0.9545	0.9820
0.4	0.9470	0.9745	0.9815	0.9943	0.9478	0.9798
0.5	0.9433	0.9761	0.9820	0.9944	0.9434	0.9797
0.6	0.9409	0.9779	0.9822	0.9953	0.9406	0.9792
0.7	0.9404	0.9812	0.9834	0.9958	0.9391	0.9809
0.8	0.9393	0.9833	0.9847	0.9961	0.9372	0.9811
0.9	0.9397	0.9845	0.9841	0.9970	0.9374	0.9830
1	0.9376	0.9865	0.9843	0.9970	0.9345	0.9823

The above tables show that the performance of the hybrid scheme is more efficient than the other tested filters.

CONCLUSIONS

A simple hybrid scheme is suggested to reduce the effect the spackle noise from the ultrasound medical images. This scheme consist from two interaction filters (wiener and mean) working with simple adaptive filter which dependent on nonlinear function in its work. A kidney ultrasound image is tested under different speckle noise variance to evaluate the performance of suggest scheme when it is compare with the performance of other filters like mean, median, wiener, M3 filter, in addition to wavelet filter. from the simulation results, the suggested hybrid scheme give more enhancement for the denoised images.

REFERENCES

- [1]. Mukesh C. G, C.M., Rakhi C. M., Frederick C. H., Jr:" Survey of image denoising techniques"; Proc. Of GSPX2004, Santa Clara Convention Center, Santa Clara, CA, pp.27-30.
- [2]. Thangavel , K. R. Manavalan, I. Laurence Aroquiaraj:" Removal of Speckle Noise from Ultrasound Medical Image based on Special Filters: Comparative Study"; ICGST-GVIP Journal, ISSN 1687-398X, Volume (9), Issue (III), June 2009.
- [3]. Umadevi,N. Dr. S.N.Geethalakshmi:" IMPROVED HYBRID MODEL FOR DENOISING POISSON CORRUPTED XRAY IMAGES"; International Journal on Computer Science and Engineering (IJCSE), ISSN : 0975-3397 Vol. 3 No. 7 p2610-, July 2011.
- [4]. Lee and I. Jurkevich, J. S. "Speckle filtering of synthetic aperture radar images: A review," Remote Sensing Reviews, vol. 8, pp. 313–340, 1994.
- [5]. Loupas, T. W. N. McDicken, and P. L. Allan, "An adaptive weighted median filter for speckle suppression in medical ultrasonic images," IEEE Trans. Circuits and Systems, vol. 36, pp. 129–135, 1989.
- [6]. Vishwa,. A. S. Sharma;" Speckle Noise Reduction in Ultrasound Images by Wavelet Thresholding "; International Journal of Advanced Research in Computer Science and Software Engineering; Volume 2, Issue 2, February 2012 ISSN: 2277 128X.
- [7]. Saleh Al-amri , S. N.V. Kalyankar " A Comparative Study of Removal Noise from Remote Sensing Image"; IJCSI International Journal of Computer Science Issues, Vol. 7, Issue. 1, No. 1, January 2010 32 ISSN (Online): 1694-0784 ISSN (Print): 1694-0814
- [8]. Padmavathi, G. P.Subashini, M.Muthukumar:" Performance analysis of Non Linear Filtering Algorithms for underwater images"; SENSORS, SIGNALS, VISUALIZATION, IMAGING, SIMULATION AND MATERIALS; ISSN: 1790-5117; ISBN: 978-960-474-135-9;pp.179-184;
- [9]. Sudha,S. G.R.Suresh, R.Sukanesh" Comparative Study on Speckle Noise Suppression Techniques for Ultrasound Images"; International Journal of Engineering and Technology Vol. 1, No. 1, April, 2009,. 1793-8236
- [10]. Sudha, S. G.R.Suresh and R.Sukanesh:"Speckle Noise Reduction in Ultrasound Images by Wavelet thresholding based on Weighted Variance"; International Journal of Computer Theory and Engineering, Vol. 1, No. 1, April 2009, 1793-8201.
- [11]. Kaur,A. Karamjeet Singh: " SPECKLE NOISE REDUCTION BY USING WAVELETS "; CI 2010 -National Conference on Computational Instrumentation CSIO Chandigarh, INDIA, 19-20, pp. 198-203, March 2010.
- [12]. Boutalis: Y." A Fast Adaptive Approach To The Restoration Of Images degraded By Noise ", Signal processing ,vol. 19, No.2 ,pp151-160,1990,
- [13]. Wang and Alan C. Bovik: Z. "A Universal Image Quality Index"; IEEE Signal Processing Letters, 9, No.3.2002.

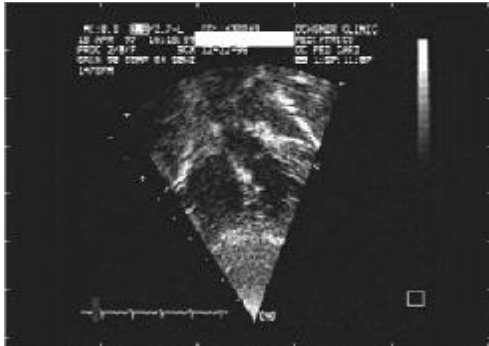

(a)- the original image.

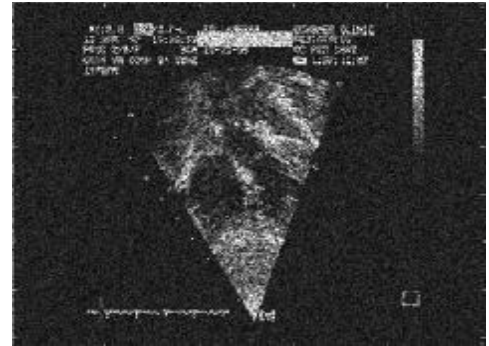

(b)-the noisy image with speckle noise variance=0.3

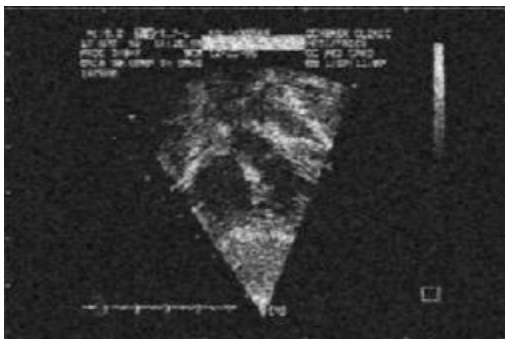

(c)-denoising by mean filter with SNR=8.9006;

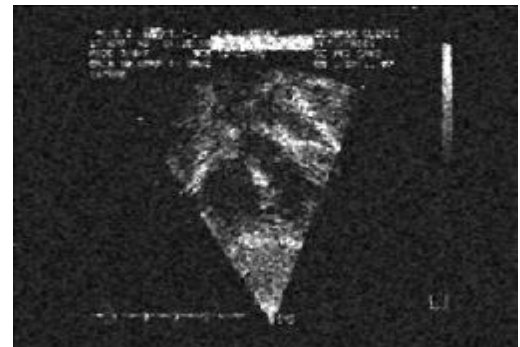

(d)-denoising by median filter with SNR=.7.7661



(e)-denoising by wiener filter with SNR=8.9478.

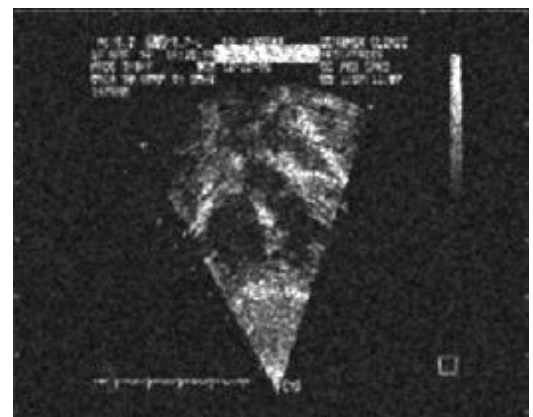

(f)-denoising by M3 filter with SNR=8.9359.

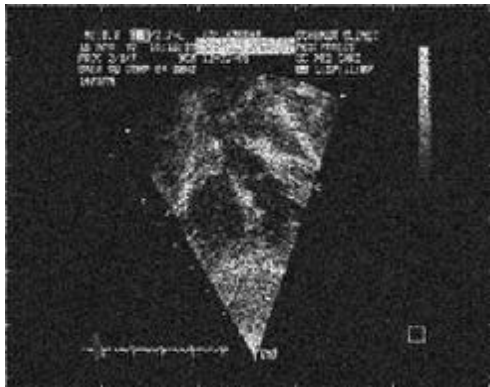

(g)-denoising by wavelet filter with SNR=9.0145.

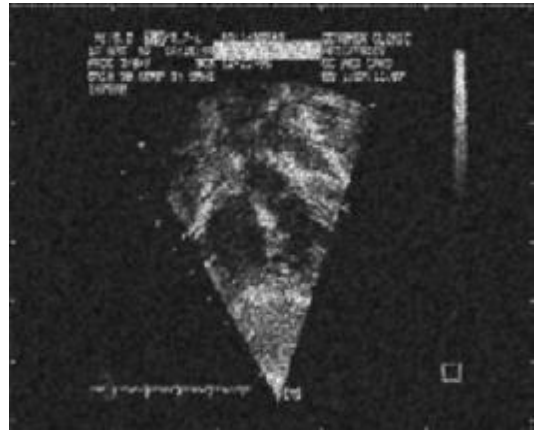

(h)-denoising by hybrid scheme filter with SNR=9.7938.

Figure (2) a)- the original image. (b)-the noisy image with speckle noise variance=0.3 and SNR=6.4252. (c)-denoising by mean filter, (d)-denoising by median filter, (e)-denoising by wiener filter, denoising by M3 filter, (g)-denoising by wavelet filter, (h)-denoising by hybrid scheme filter.