

The Photoluminescence Characteristics of Partially and Fully (P-N) Porous Silicon

Dr. Alwan M. Alwan

School of Applied sciences, University of Technology/Baghdad

Email: ALKRZM@yahoo.com.

Muna. S. M. Jawad

School of Applied sciences, University of Technology/Baghdad

Received on: 24/10/2012 & Accepted on: 31/1/2013

ABSTRACT

In this work, we present results of photoluminescence (PL) properties of fully (p-n) porous silicon device. Porous silicon layer has been prepared by Photo-electrochemical etching under different etching time of abrupt (p-n) silicon junction. The photoluminescence spectra, it is found that the formation of fully penetrate porous silicon layer can lead to decrease in the photoluminescence intensity. The reduction of the PL intensity is referred to the increase of non- radiative recombination process between the electron and hole. The obtained fully porous silicon layer in high etching time regime and this layer cannot be used for perpetration of light emitting devices, while the partially (p-n) porous silicon layer in the PL intensity has a higher value and good characteristics, this layer is suitable for (LED).

Keywords: (p-n) porous silicon, PL, photo-electrochemical etching.

خصائص التلؤلؤ الضوئي لطبقة (p-n) السيليكون المسامي جزئياً وكامل الاختراق.

الخلاصة

في هذا البحث تم دراسة خصائص التلؤلؤ الضوئي لطبقة سيليكون جزئية وكاملة المسامية. تم تحضير طبقة السيليكون المسامي باستخدام مفرق (p-n) بطريقة التتميش الكهروكيميائي-الضوئي (PEC) باستخدام ازمدة تتميش مختلفة لمفرق (p-n) سيليكوني حاد. اظهرت نتائج اطياف التلؤلؤ الضوئي تكون طبقة سيليكون مسامي كاملة الاختراق للمفرق (p-n) وهذا ادى الى انخفاض شدة التلؤلؤ الضوئي. الانخفاض في شدة التلؤلؤ الضوئي يشير الى زيادة عمليات اعادة الاتحاد الغير اشعاعي بين الالكترين-الفجوة. وان طبقة السيليكون المسامي كاملة الاختراق تتكون عند ازمان التتميش العالية وفي هذه الحالة لاتصلح لتحضير النبايط الباعثة للضوء، اما طبقة السيليكون المسامي (p-n) الجزئية الاختراق المتولدة لازمنة تتميش صغيرة للمفرق تعطي شدة PL عالية ولذلك تكون ملائمة لصنع الثنائي الباعث للضوء.

INTRODUCTION

Porous silicon has attracted the attention of many experimental and theoretical researches [1,2], due to their particular photoluminescence in the visible range and at room temperature [3]. Porous silicon find application in a large number of domains such as microelectronics, optoelectronics [4], chemical [5] and biological [6-7] sensors and biomedical devices [8]. However, the instability of the hydro-silicon bond, which can undergo spontaneous oxidation in ambient atmosphere and results in the degradation of the surface structures and photoluminescence properties, remains a key issue for industrial production [9]. In this work, study the Photoluminescence (PL) properties of partially and fully (p-n) porous silicon layer (p-n) PSi as a function of etching time. Porous silicon prepared by Photo-electrochemical etching of abrupt (p-n) junction.

EXPERIMENTAL WORK

The silicon samples were (1*1.5) cm². The etching process was carried out using photo-electrochemical etching process which employed 632.8 nm He:Ne laser at different etching times (3,5,10,15,20,25) min. The irradiated area was about 1.4 cm² and power density was fixed to 10.7min. samples are dipped into mixture of HF:Ethanol,(1:1). The etching process was materialized in specially designed cell. Which consists of two – electrode system as an anode and a mesh as cathode. The experiment was conducted in room temperature and is shown in the Figure (1). The cell provides us a porous silicon layer of uniform cross sectional area. The PL spectrum was performed with PL system (HR 800UV, Jobin Yvon) by exciting the synthesized layer with a (He.Cd) laser operating at (325nm) wavelength at low laser power density of nearly 10 mW/cm². SEM type (JSM-6460 LV). The SEM measurements and PL measurements were carried out in the school of material engineering at the University Sains Malaysia in Penang. This uniformity is recommended for the application of porous silicon and photovoltaic cells. The cross section of the home-made cell is shown in Figure (1), in which a mesh cathode with size aperture (1*1mm) was used, Figure (2): shown the p-n porous samples after etching process has uniform circle.

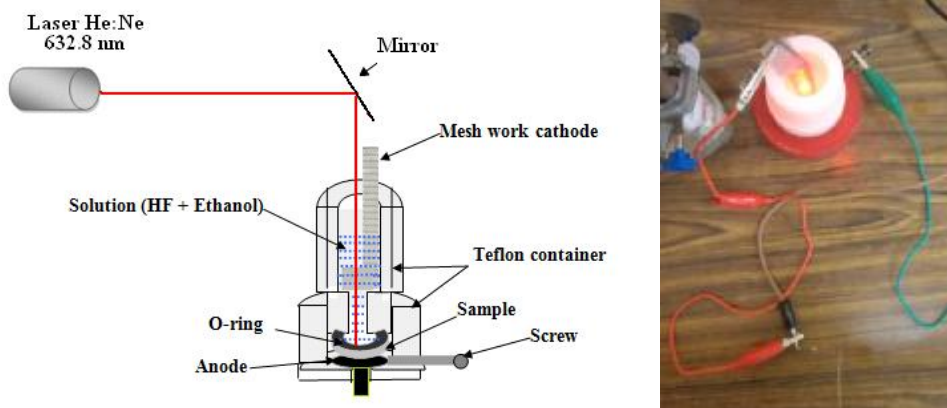

Figure (1) The cross section of cell used in the work (schematic diagram).

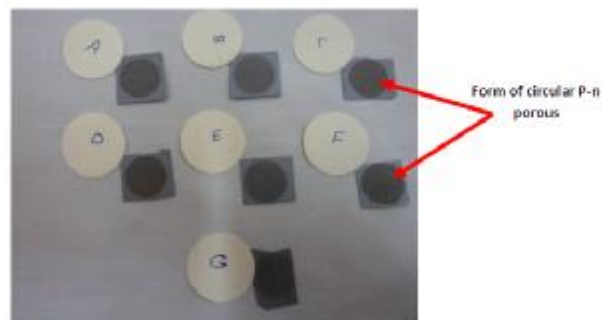

Figure (2) the p-n porous samples of uniform circular.

RESULTS AND DISCUSSION

In order to include the widest range of crystallites to be excited as shown in Figure (3a), Figure (3b) and Figure (3c) which represented at low etching time of (3 min, 5 min, and 10 min) respectively. All the figures show PL curves with sharp peak intensity at different wavelength which refereeing to a porous layer with significant with silicon nano size within the layer [10].

Since the photo energy is larger than the band gap energy of the produced nanocrystallites. Therefore, efficient absorption could be taken place leading to contribute a wide range of crystallites sizes with the (n porous layer and the p porous layer). The PL peak intensity show maximum valued of about (444.980 a.u) at etching time of (5) min. This enhancement at PL intensity is generally attributed to quantum size effects in nanostructures the increase in etching time leads to the transformation of some silicon nano-wires to more energies quantum dots [11]. The increase of PL intensity may be also attributed to the increase of the volume, from equation (1) calculated energy band gap of porous silicon which depends on the wavelength.

$$E_{g^*} = \frac{hc}{\lambda} \quad \dots(1)$$

Where λ (nm) is the wavelength calculated from PL spectrum, E_{g^*} (eV) is the energy band gap of silicon nano size, c (m/min) Speed of light in a vacuum, h (J.s) Blank constant.

Based on the energy gap of silicon nano wire in the layer, average nanocrystallinities in the PSi layer calculated according to the following equation (2) [12]:

$$E_{g^*} = E_g + \frac{88.34}{L(1.37)} \quad \dots(2)$$

Where (L) (\AA) is the porous silicon average nanocrystallinities in the layer. E_{g^*} (eV) is the energy band gap of silicon nano wire, E_g (eV) is energy band gap of bulk silicon [5].

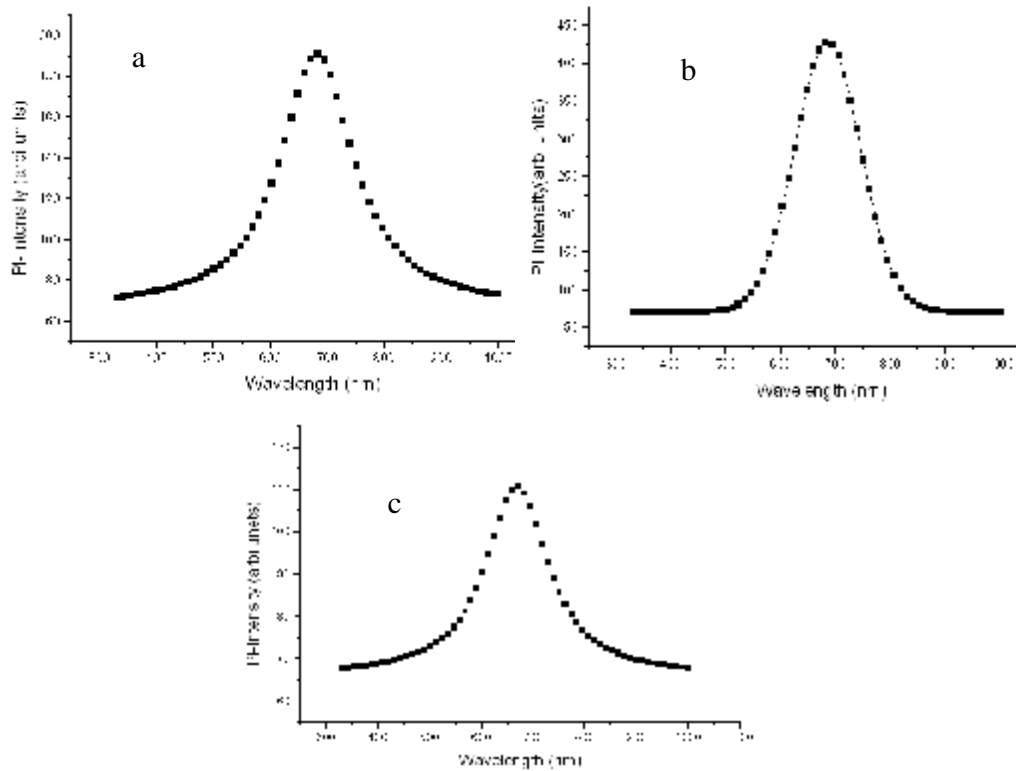
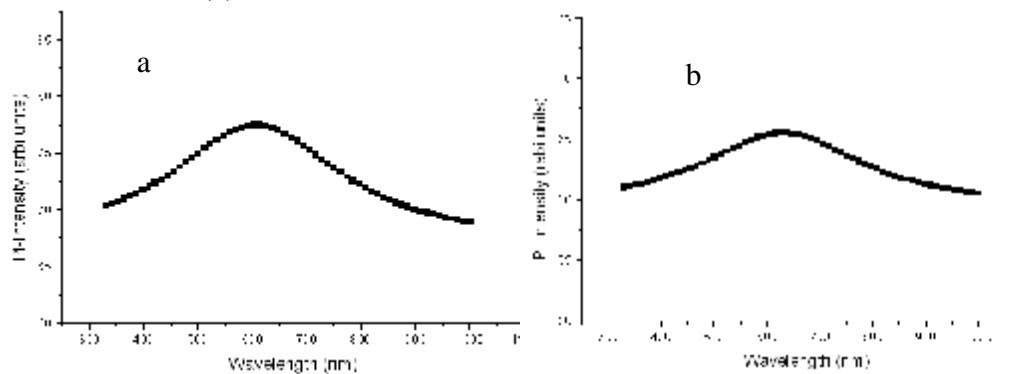

Figure (3) Photoluminescence spectrum of the p-n porous sample prepared at low etching time (a) 3 min, (b) 5 min, (c) 10 min.

in order to include the widest range of crystallites to be excited as shown in figure (4a), Figure (4b) and Figure (4c) which represented at high etching time of (15 min, 20min, and 25min) respectively. All the figures show PL curves with shallow peak intensity at different wavelength which refereeing to a porous layer with small amount of silicon nano size within the layer [13].

The PL peak intensity show maximum valued of about (77.499 a.u) at etching time of (15) min. this new value of peak PL intensity which is very small compared with the results of low etching time. This degradation in the PL intensity is generally attributed to the large number of dangling bonds in porous silicon is comparable to those in the surface of bulk silicon, a huge number of dangling bonds in porous silicon would exist because of enormous surface area opening into air. These bonds can provide an important channel for non - radiative recombination [14].

As a results of quantum size effects in nanostructures the increase in etching time leads to the transformation of some silicon nano-wires to more energies quantum dots [15] this case is shown in the etching time of (25) min where the energy gab is reached to a higher value is about (2.3) eV. The decrease of PL intensity may be also attributed to the decrease of the silicon nano-crystallites density in the PSi layer. Many of researchers are attributed that the decreasing in the PL intensity in the (p-n) porous silicon to the decrease in the density of the luminance crystallites resulted from increasing of non – radiative recombination centers (dangling bonds). [5]. Results are outlined in Table (1).



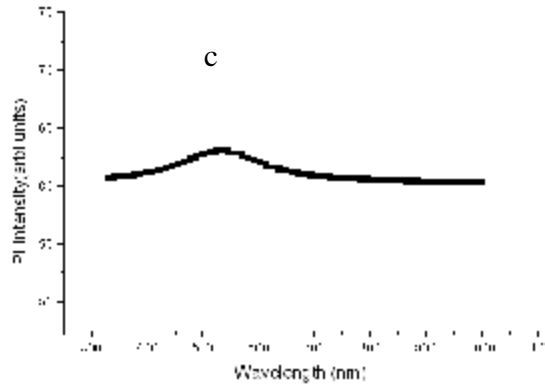

Figure (4) Photoluminescence spectrum of the p-n porous sample prepared at high etching time (a) 15 min, (b) 20 min, (c) 25 min.

Table (1) Illustrate the emission peak wavelength, energy gap and average size of silicon nanocrystallites the p-n porous samples with different etching time.

Etching time (min)	Wavelength peak λ (nm)	Peak PL intensity (a.u)	Energy gab of P <i>Si</i> (eV)	average nanocrystallities (nm)
3	682	191.108	1.822	3.5
5	704	444.980	1.763	3.7
10	670	110.703	1.853	3.3
15	602	77.499	2.063	2.7
20	625	65.544	1.988	2.9
25	534	63.056	2.326	2.2

In Figure (5) which represented an etching time of (3,5,15,20)min. Increasing the etching time will form a complex silicon nanowire matrix system of different size and the morphological nature of the etched surfaces show a different pores, trenches size and shapes. These pores and trenches are aligned in random direction and the pores widths are increased with increasing the etching time. This layer has pores and trenches with various sizes and shapes in micro and nano silicon regions. This structures is shown also by Unal and Baylisis[16], in etching of the n-layer. Large scale trenches do

not appear with shorter etching time but the thickness of the porous layer decreases. And got the partially p-n porous silicon layer. See in Figures (5a), (5b) [16].

Figure (5c), (5d) illustrates the morphological characteristics at etching time (15)min, (20)min in which a nearly a pore like structure of array of small number of large pore width with nearly cylindrical pores shape. This growth in pore width may be attributed to an increasing holes number on the silicon surface with increasing the laser intensity leading to a preferential dissolution between nearest - neighbor's pores which promotes the pore-pore overlap. However, the etching rates may be different and this could lead to a non- uniformity in the values of the pores width [13]. Got a fully porous silicon layer [16].

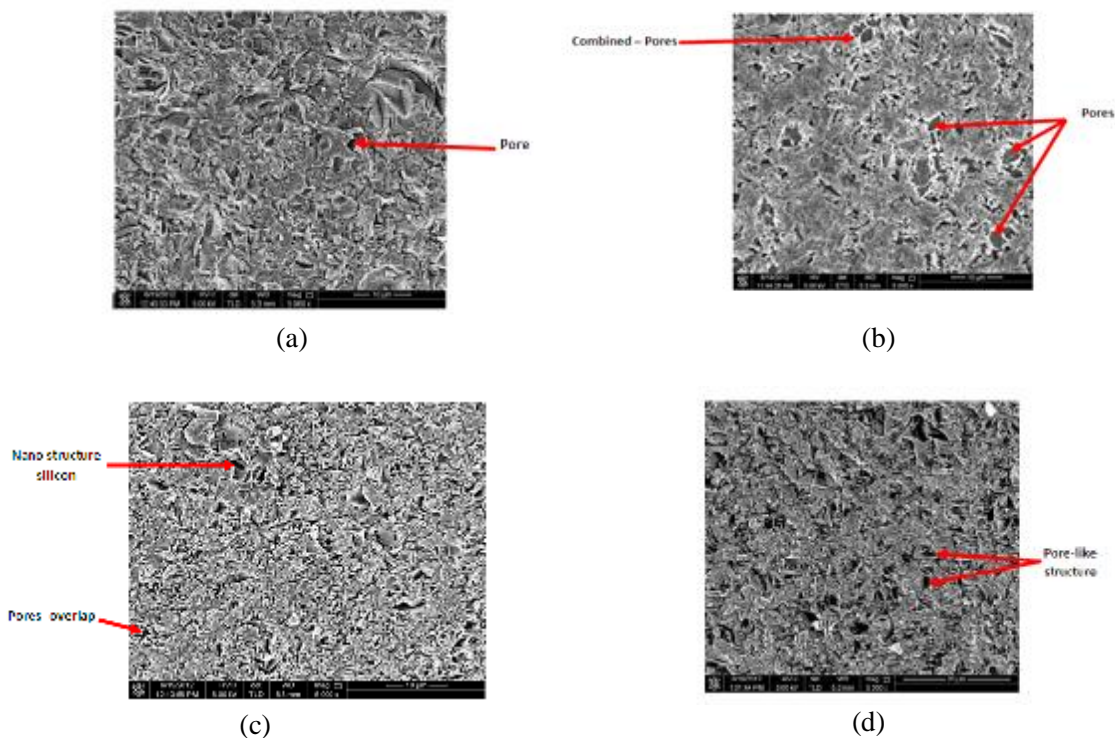

Figure (5) SEM image (top - view) of the p-n porous sample prepared at different etching time (a) 3min, (b) 5min, (c) 15min, (d) 20 min at magnification 5000 times.

Figure (6) presents the PL peak intensity from porous silicon layer as a function to PSi layer thickness. From this figure we can show the there is a specific PSi layer thickness in which the PL intensity increased to maximum values this layer is about (5) μ m. The decreasing of the PL peak intensity with increasing PSi layer thickness is due to the increasing of the specific surface area which is increasing with increasing

the porosity and the layer thickness[5]. When the specific surface area increase the density of the non recombination centers (dangling – band) reduced to higher value, and finally the P*Si* material will converts from radiative to non radiative material [17].

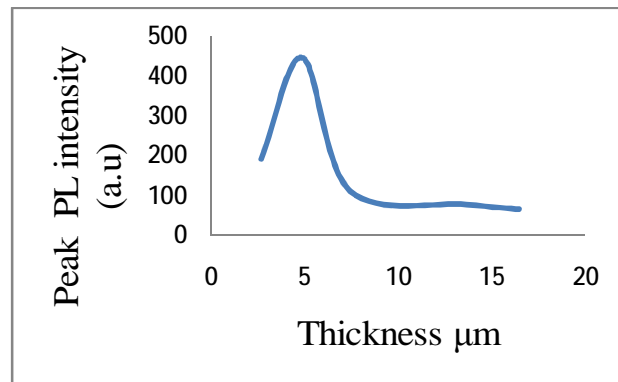

Figure (6) Photoluminescence peak intensity as a function of (p-n) P*Si* layer thickness.

CONCLUSIONS

The density of nano structure size region in (p-n) porous silicon layer at low etching time is higher than the micro structure region. The PL measurements show high peak intensity at low etching time especially at (5min) due to the high density of silicon nano structure at the (p-n) porous silicon layer and this layer behavior as light emitting porous silicon layer LEPSi. The PL measurements show low peak intensity at high etching time due to the low density of silicon nano structure region. The reduction of the PL intensity is referring to the increase of non- radiative recombination process. With increasing etching time the (n) layer was fully etched and entering to the (p) layer in the (p-n) porous silicon layer.

REFERENCES

- [1]. Lugo, J.E. J.A. del Rio, J. Taguena-Martinez, Sol. Energy Mater. Sol. Cells, Vol. 52 (1998).
- [2]. Bisi, O. Stefano Ossicini, L. Pavesi, Surf. Sci. Rep, Vol. 38 (2000).
- [3] Andrea Edit Pap, Kriszti Kordas, Jouko Vahakangas, Antti Uusimaki, Seppo Leppavuori, Laurent Pilon, Sandor Szatmari, Opt. Mater. Vol. 28 (2006).
- [4] Sondyan Chen, Yanhua Huang, Beini Cai, Solid State Electron. Vol.49 (2005).
- [5]. Canham, L.T. Appl. Phys. Lett. Vol.57 (1990).
- [6]. Collins, R.T. P.M. Fauchet, M.A. Tischler, Phys. Today Vol.50 (1997).
- [7]. Lazarouk, S. P. Jaguiro, S. Katsouba, et al., Appl. Phys. Lett. Vol. 68 (1996).
- [8]. Steiner, P. F. Kozlowski, W. Lang, Appl. Phys. Lett. Vol. 62 (1993).

- [9]A. Richter, P. Steiner, F. Kozlowski, W. Lang, IEEE Electron Devices Lett. Vol.12 (1991).
- [10]. Zhou,F. Y. M. Huang Applied Surface Science Vol.253, (2007).
- [11]. Gelloz, B. A. Bsiesy, N. Koshida. Japan. Journal of Porous Materials Vol.7, (2000).
- [12]. Hyounglee, W. choochon Lee and J. Jang, Journal of Nano-crystalline solids, Vol.1981, (1996).
- [13]. Starovoitov and S. Bayliss.A. Appl. Phys. Lett., Vol. 73, No. 9, (1998).
- [14]. Henley,W. Y. Koshka, J. Lagowski, and J. Siejka. J. Appl. Phys. Vol. 87, No.11 (2000).
- [15].Lynne Koker, phys.chem Vol.52, No.2, (1999).
- [16].Unal. B. Bayliss. SC. J. Appl. Phys. Vol. 80, (1996).
- [17]. Bacci, N. A. Diligenti, and G. Barillaro J. Appl. Phys. Vol. 110, No. (3), (2011).