

## Design, Simulation and Implementation of DC Motor Drive

Hameed Aubaid Ali

Ministry of Industry and Metals /Baghdad

EngHameed41@yahoo.com

Dr. Majid K. Al-Khatat

Electrical and Electronic Engineering Department, University of Technology/Baghdad

Received on: 6/11/2012 & Accepted on:3/10/2013

### ABSTRACT

In this paper, a suitable design of a dc controller is proposed and implemented, as a prototype and for a software simulation, so that is capable to overcome different hazards in operation. Different techniques were selected to reach the efficient operation speed control unit. A simple and efficient firing unit is built, especially for this controller which can be implemented and repaired. The armature model has been built up and it is used in the simulation design in order to represents the armature rotation and operation study possible under different conditions. From the OrCAD Pspice 16.9 Simulator ,some transient and steady state results were taken like (voltage, current, torque, speed),at load and no load conditions. An open loop prototype drive were implemented and operated, so that deferent results were taken, this results comparing with a theory refers to good agreement .

**Keywords:** Dc Motor Drive, Firing Circuit. Controller, Orcad Pspice 16.9.

### تصميم , نمذجه, وتنفيذ مسوق قدرة لمحرك التيار المستمر

#### الخلاصة

في هذا البحث, تم التوصل إلى وضع تصميم مناسب لوحدة سيطرة أحادية الطور على محركات التيار المستمر وتم تنفيذها, بحيث تكون لها القابلية على التغلب على مختلف الظروف غير الاعتيادية في التلاخيل وتم تنفيذ مسيطر ذو داره مفتوحة. تم اختيار مختلف التقنيات لتحسين عمل هذا المسيطر. من هذه التقنيات تصميم وحدة قرح بسيطة وكفاءة وضعت خصيصا لهذا النوع من المسوقات والتي يمكن التحكم بها وصيانتها بسهولة. تم في هذا البحث أيضا تصميم موديل الجزء الدوار أضيف الى برنامج " OrCad " استخدم في التحليل الحاسوبي, يمكن من خلاله تمثيل دوران هذا الجزء وعمله لمختلف الحالات المعروفة. أخذت الحالات العابرة (Transient) مثل, (الجهد, التيار, العزم, السرعة) في وضع عدم التحميل وفي وضع التحميل من برنامج المحاكاة "OrCad Pspice" وقد وجدت إنها جيدة ومطابقة تقريبا للحالة النظرية. تم عمل نموذج عملي لهذا المسيطر ذو داره مفتوحة وتشغيله, حيث تم اخذ النتائج لمختلف مراحل المسيطر و قورنت مع النتائج النظرية, ومثيلاتها من برنامج المحاكاة وكانت مطابقة للحالة النظرية

## **INTRODUCTION**

**D**irect current drives are widely used in industry. The best advantages of these drives like, ease of control, stability, speed control over a wide range, rapid response to speed change, and it is the better safety ensure their popularity for a long time.

The controlled (thyristor) rectifier provides a low-impedance adjustable 'd.c.' voltage for the motor armature, thereby providing speed control, thyristor converters which offered cheaper first cost, higher efficiency (typically over 95%), smaller size, reduced maintenance, and faster response to changes in set speed.

In phase-controlled DC drives an ac to dc phase-controlled converter is used to control DC drive motor. The converter changes the ac input voltage to controllable dc output voltage. In such converters thyristor commutation (i.e. transfer of current from one thyristor to the next) is easily achieved by a process referred to as natural or line commutation. When an incoming thyristor is turned ON, it immediately reverse -biases the outgoing thyristor and turns it OFF. No additional circuitry is required for the commutation process phase- controlled converters are simpler and less expensive and are extensively used in industries application such as variable-speed reversing drives for rolling Mills, the power rating may be as high as several megawatts [1,2].

## **GENERAL DC-MOTOR DRIVE COMPONENTS AND MODULES**

The most important component units of the Dc-motor drive system which was used in our factories and has been given in Indramat German company [3] are:

- 1) Control power supply section.
- 2) Control unit section.
- 3) Firing circuit and synchronization section.
- 4) Power converter section.

All units of this drive was fabricated as a hybrid integrated modules. These hybrid modules are subjected to defect and cannot substituted because it's not commercial and its costly .

In this work more than unit has been simplified and imitated so that changes to a discrete components to become familiar with our market and easier to change or repair. Phase control firing unit has been designed, with a simple control circuit like supplies , power amplifier, power thyristor, and reference signal which is depends on the same principle of basic standard typical controller. Some techniques was not used because of the difficulties such as (speed adaption, linearization, dynamic current limitation.

## **DESIGN,SIMULATION AND IMPLEMENTATION**

The use of simulation has always been a powerful tool for the technology in all its various fields of application. The analytical software simulator provides a study of system operation and optimize its performance, besides to examine transient response in addition to the steady state behavior. One of the most commonly used program is OrCAD pspice program, which provides us a highly precision analysis for study and tracking the circuit operation , also it can be observed more than one result at one time [4,5]. In this work, a complete drive system is modeled, implemented and simulated

for open loop system states. In addition practical design implementation of the drive and prototype dc motor has been tested and compared with simulation results.

### **Firing Circuit Design Simulation and Implementation**

In phase-controlled converter, it is assumed that the thyristors (SCR<sub>s</sub>) are fired at  $\alpha$  desired instant for proper operation. The firing instant is controlled by control signal so that the converter can provide a desired output performance. The firing circuit consists of four dual stages Figure (1) shows a block diagram for the firing circuit, that consists of the following units:

- 1) Integrator.
- 2) Comparator .
- 3) Monostables.
- 4) Digital part.

#### **Integrator**

It is the most important part of the circuit, this part delivers a signal from step down-transform as a sine wave signal, then converts it to a cosine signal by varying ( V, R, R, C ) some important remarks can summarized as follows.

- 1) Accuracy of converting .
- 2) Steady state time( SS) before the o/p becomes stable.
- 3) Cross-Level calibration between positive and negative sides.
- 4) Amplitude of o/p signal.

By experimental with back ground theory many sets of ( R , Rin , C V ) used . Figure (2) shows the integrator circuit, the most accurate set is design as:  
 $R = 30K\Omega$  ,  $R_{in} = 7K\Omega$  ,  $C = 1\mu f$      $V_{in} = 24V$  .

The results of this design shows a high closely cosin wave conversions , suitable magnitude about ( + - 12V ) and short steady state time. The graphs shown in Figure (3 ) shows the Integrator o/p wave in analogue & logarithm time axes. The S. S. T =70ms .

where S.S.T is the steady state time.

#### **Comparator**

The second part of firing circuit is the comparator where the  $V_C$  compares with o/p of the integrator (cosine signal) to generate firing pulses at the crossing point between them ,  $\alpha$  is given by,

$$A = \cos^{-1}\left(\frac{v_c}{e_{max}}\right) \quad \dots (1)$$

Where

$e_{max}$  is the instantaneous value of  $v_{in}$

The o/p voltage of thyristor is given by,

$$E_O = E_{max} \cos\alpha \quad \dots (2)$$

Where

$E_O$  is the o/p of converter,

At first side of the firing circuit the control voltage  $v_c$  compare with a cosine signal  $e_b$  in the comparator u3 to produce a signal. This signal then inverted by inverter u5 as a signal  $e_f$  to fed to the fourth stage of the circuit that is a monostable U7. The same operation is happened in the second side of the circuit. The inverted  $v_c$ ,  $e_d$  are compare with a cosine signal  $e_b$  at a comparator u4 to produce a signal  $e_h$  that is fed to a monostable u8.

### **Monostable**

A third part of the firing circuit consists of one monostable circuit at any side of the firing circuit, this monostable circuit delivers a signal,  $e_f$  from the first side,  $e_h$  from the second side. The monostable circuit is designed to provide suitable triggering pulses to a digital section, the o/p<sub>s</sub> of the monostables circuits which are op1, op2 have enough magnitude and suitable (ON, OFF) time Figure (4) shows the monostable stage and total firing system[6].

Transient simulation has been done, the earlier pulses uncontrolled ,three pulses was changed in width and location. Figure (5) shows four graphs as follows:

- 1) Cosine signal (output of comparator), positive & negative control voltage.
- 2) Firing pulses out from first comparator .
- 3) Firing pulses out from second comparator .
- 4) Triggering output from monostable circuit.

The pulses in the fourth graph are used to control the positive halve cycle of power, the green pulses are used to control the negative halve cycle .

### **Digital part**

The digital part consists of two elements :

- a) RS-FF.
- b) Two AND gates .

The signals op1, op2 come from monostables feeds to Set, Rest of RS-FF to generate  $q$ ,  $q^-$  pulses. These pulses are fed to the AND gates to generate a triggering signals op3, op4 that used to fire the circuit of SCR<sub>s</sub> in positive and negative halve cycle. Figure (6) shows the digital part of the firing circuit, Figure (7) shows the NAND-Gate waveform.

### **ARMATURE MODEL CIRCUIT**

The complete design of the armature model circuit is schematically represented to the OrCAD simulation as shown in Figure (8). Where A is the o/p of the thyristors bridge. The blocks in side the diagram are described the behaviors of the Dc motor and it is armature rotation. These are building in the OrCAD program.

The software implementation requires a model to describe the function of the armature rotations and other models to deduce the main parameters required for testing the simulation. Some behavior parts that are operated by definitions and/or software expressions. Many analogue behavioral model circuit used for a first time in this work and added to the design circuit so that the measurement of the important parameters such as(torque, speed, firing angle ,etc) can be applied. The block circuits can be subdivided to:

- 1)Armature Behavior part (ABP).

- 2) Torque Behavior part (TBP).
- 3) Speed Behavior Part (SBP).
- 4) Buffer Behavior Part (BBP).

The inside functions of the above behavior parts are well derived and analysis in [7].

### **PRACTICAL PROTOTYPE DRIVE**

The practical circuit was implemented and built on a board by using the same elements that used in the simulated circuit. Some differences were happened between the simulation results compared with the practical results. All the problems was solved at last, by changing the incorrect values of components under try and error or skill techniques, the results and graphs that was taken from the board or a computer shows very close results with the theory.

#### **Timing clock circuit:**

The Simulator program OrCAD in a computer has the stimulus Clock where used to operate the digital part, a 200 $\mu$ s timing clock circuit was designed by OrCAD program.

The practical output waveform of the clock obtained by oscilloscope shown in Figure(9). Some test graphs had been taken from a board at the same operation points that was taken in a simulated circuit, Figure (10) shows the o/p of comparator, Figure (11) shows the o/p waveform of monostable element. These results are typical compatible to theory[ 1,8].

### **EXPERIMENTAL TESTS OF THE DRIVER MODEL**

A practical model of the single- phase DC drive system which was designed and fed a prototype dc motor of (3000 rpm), (100) watts and (35Vdc) is shown in Figure (12). The open loop state drive system has been successfully driven the dc motor in different firing angles and speed.

In this practical work, the snubber parameters are adjusted up or down, in the final power circuit so that to obtain a satisfactory performance of the thyristor power section. This step of the practical proposed had been taken long time. The values of the power thyristor section with its snubber circuit is shown in Figure(13).

The speed of the dc motor for deferent firing angles for noload and load have been measured as shown in table (1). The values in Table (1), was put in agraph which be shown in Figure (14).

Some selective experemental test results have been taken using a compatible oscilloscope. Figure (15a) shows the signal of the secondary of the pulse transformer operating at 45kHz frequency. This trigger voltage waveform has very small DC component that satisfies the thyristor conductance. The gate-cathode voltage waveform under load condition shown in figure (15b), and this waveform shows a very close result compared with theoretical one . The Experimantal output DC voltage of the thyristor is shown in Figure (15c).

### **DISCUSSION**

The following remarks can be noted:

- 1) The output of the integrator in both practical and simulation are very close.

- 2) The waveforms have been observed for different stages of the analogue part of the firing circuit in both simulation and practice are close .
- 3) The waveforms obtained from the electronic board for the timing click circuit is a typical as in electronic theory.
- 4) The output of the digital part and pulse amplifier unit in both practical and simulation are similar to theoretical .
- 5) The thyristors output waveforms in both practical and simulation shown in are close.

Note that some distortion present in the output waveform of the converter due to power quality of voltage supply and transient conditions.

### **CONCLUSIONS**

A complete simple and easy industrial model of a single-phase DC motor drive was used in this work .Design ,implementation and simulation are presented.Hence the drive system is implemented using simple and available components.

According to the study and analysis of the proposed drive system, the main concluding remarks can be summarized as follows :

- a) All isolation controller section of the DC motor drive are modeled, implemented and simulated using OrCAD Pspice program. The OrCAD software provides a powerful and efficient environment for servo drive system. Therefore, a complete performance characteristics can be obtained.
- b) A modification in the controller sections in open are developed.
- c)The armature model is presented and developed to get a full implementation for analysis and study all possible conditions of the drive system at dynamic state at sudden load condition.
- d) The design and implementation of drive model are proposed and developed. The main units of the controller system have been experimentally tested and it is found the design is very smooth and efficient. These units include the control, firing and power section.
- e) The experimental and simulation results are consistent with the theoretical analysis and the model is very accurate and practicable.

### **REFERENCES**

- [1]. Sen, P.C. "Thyristor DC Drive ",Wiley Interescince publication, 1981.
- [2]. Richard R. Bonert "Automatic Speed Control of one Quadrant DC Drives", IEEE Transaction on Industry Applications, Vol. IA (18), pp. 347-352, 1983.
- [3]. Indramat Company Manual "Tree Axes Single Phase DC Drive", 1987.
- [4]. On line, "OrCAD Release Manual", ORcad Inc, Copany , USA, Inc 2011.
- [5]. Rashid,M. H. "SPise for Power Electronics and Electric Power" , Academic Press, 2006.
- [6]. Rashid, M. H . "Electronics Handbook, Circuits, and Applications" , Acadmic Press , 2010.
- [7]. Ali,H. A. " Simulation and Implementation of DC Motor drive", University of Technology,2012.
- [8]. Sen,P .C. "Power Electronics Handbook", 3<sup>rd</sup> Edition, 1988.

Table (1) Speed agenst  $\alpha$  values for noload and load.

$\alpha$	speed (rpm) At no load	speed (rpm) At load
90	0	0
75	900	400
60	1600	900
45	1800	1400
30	2500	1800
15	2800	2500

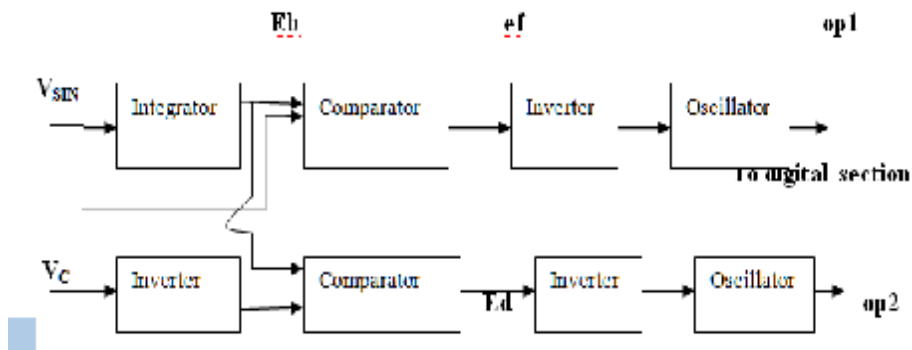

Figure (1) Block Diagram for the Firing Circuit.

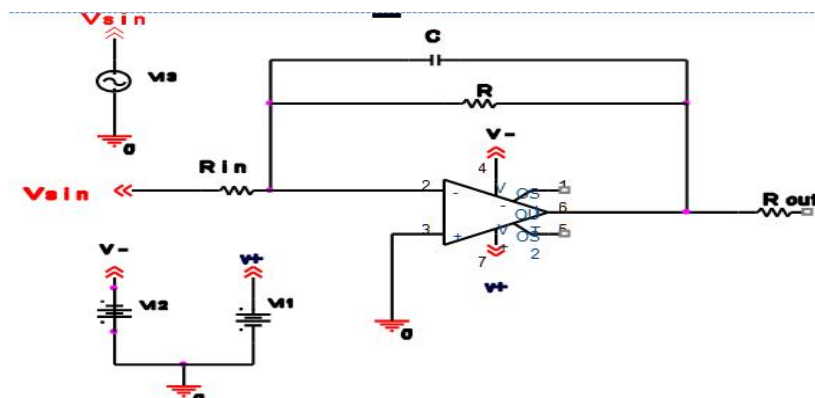

Figure (2) Integrator circuit diagram with its suppliers.

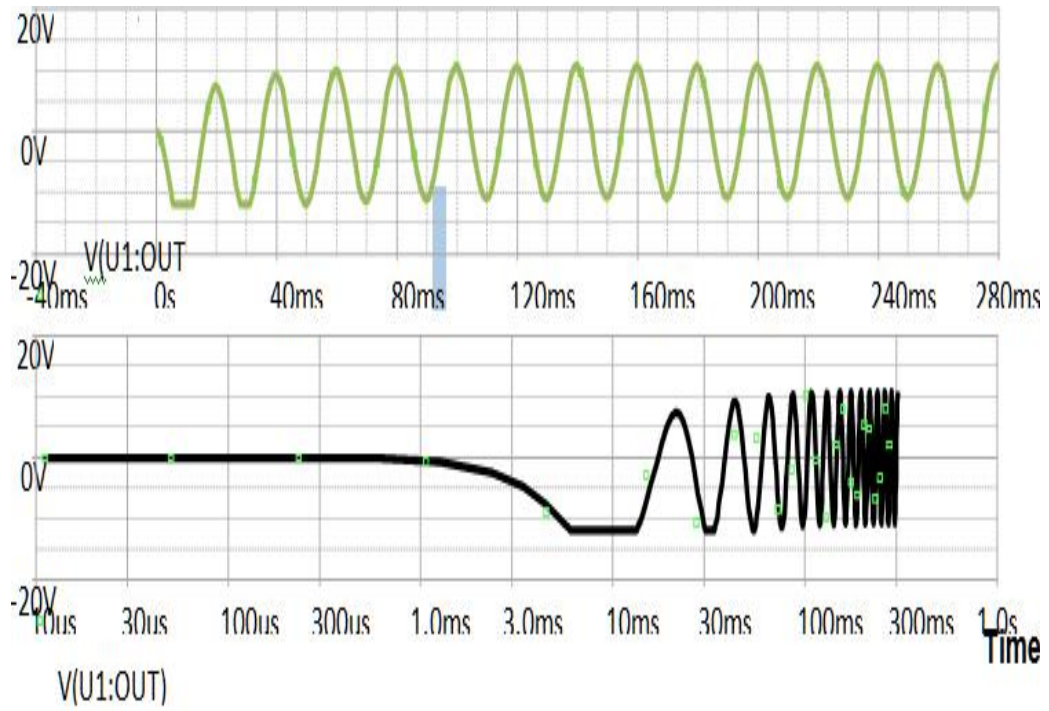

Figure (3) O/p Waveform of Integrator.



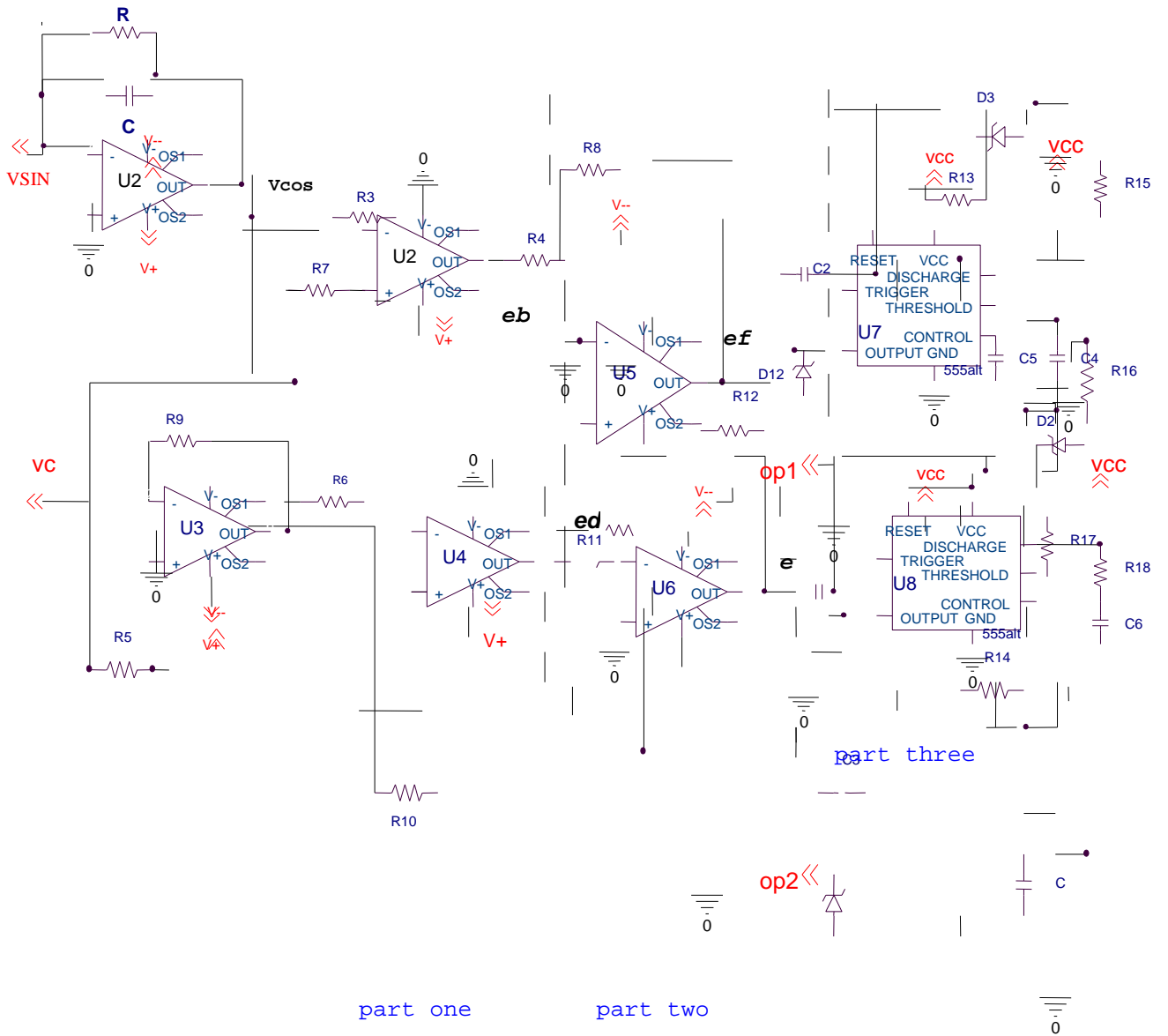
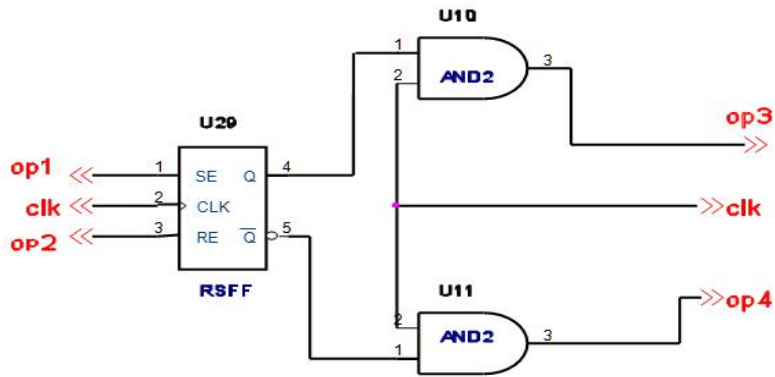

Figure (4) Firing system (Integrator, Comparators, Monostables)



**Figure (5) O/p of firing circuit stages.**



**Figure (6) Digital Part of Firing Circuit.**

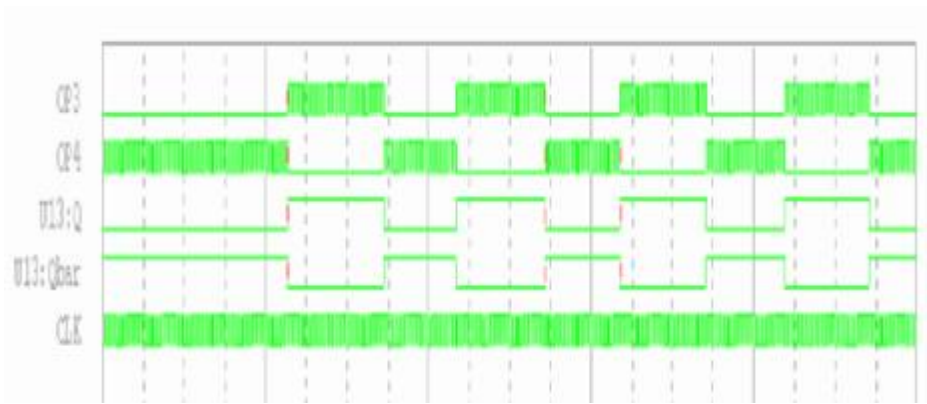

Figure (7) O/p of AND gats, FF, & clock.

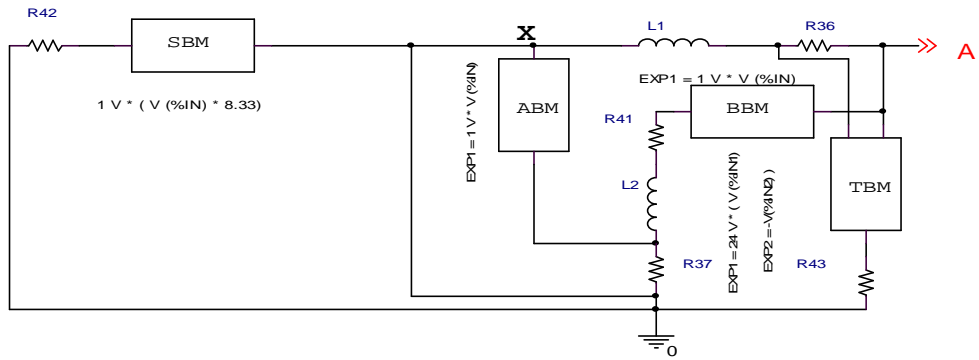

Figure (8) complete armature model circuit.

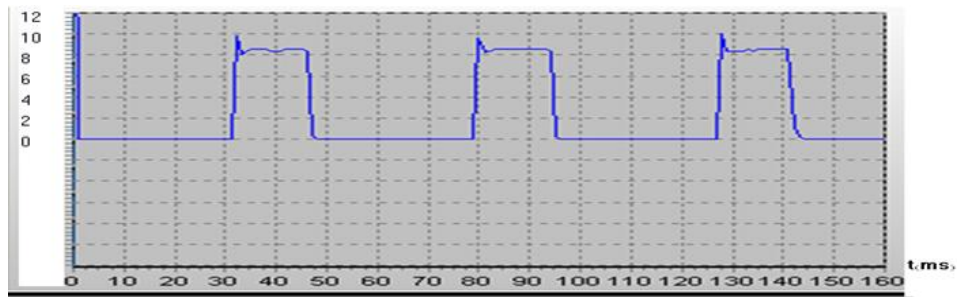

Figure (9) O/p waveform of the clock circuit.

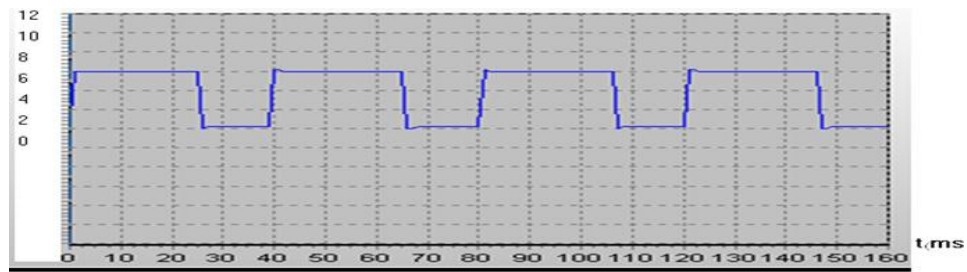

Figure (10)O/P waveform of comparator.

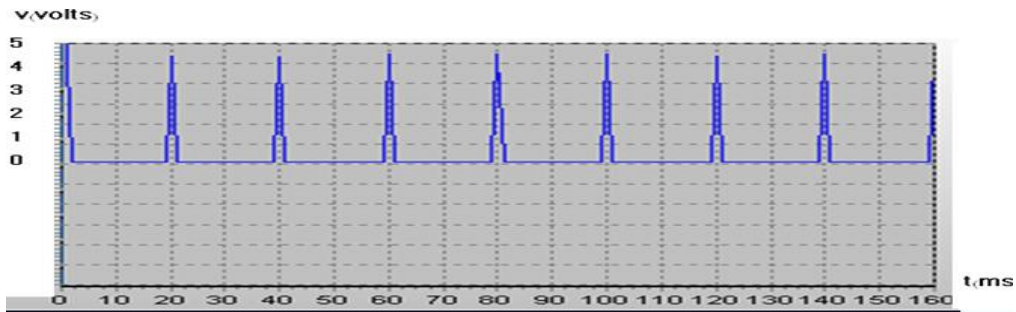

Figure (11) O/p of monostable circuit.



Figure (12) Implemented Prototype Drive.

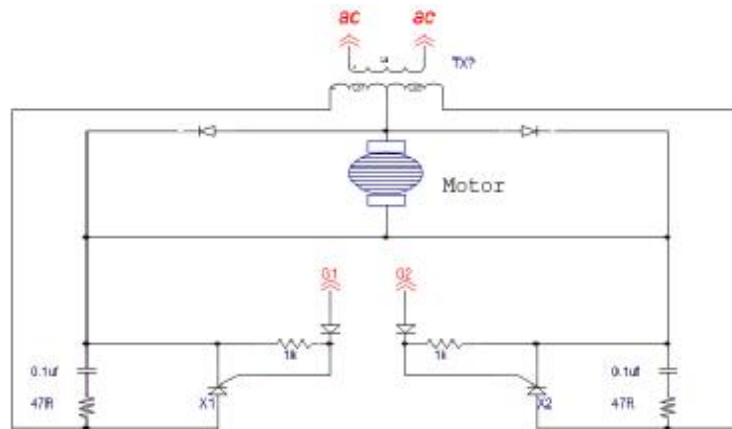

Figure (13) Power thyristor section.

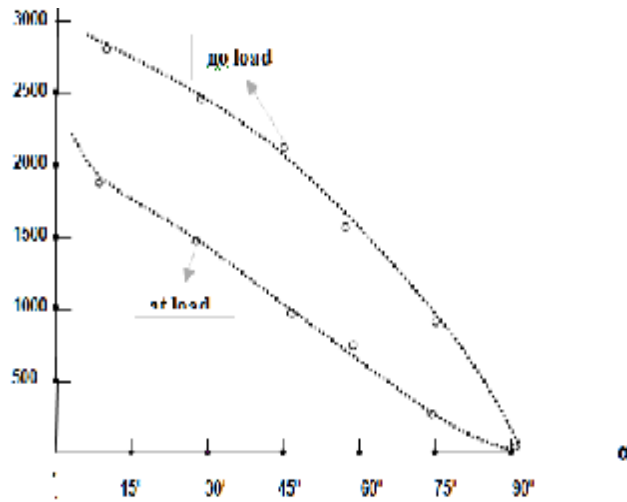

Figure (14) Speed aganst  $\alpha$  graphs for noload and load.

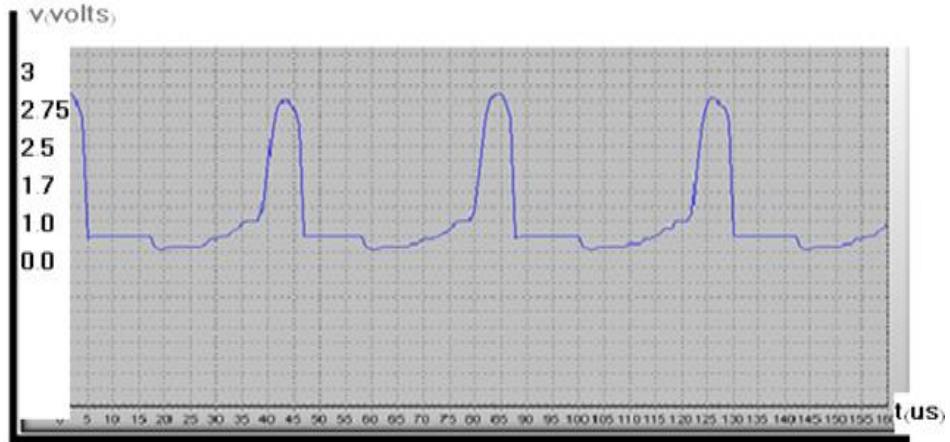
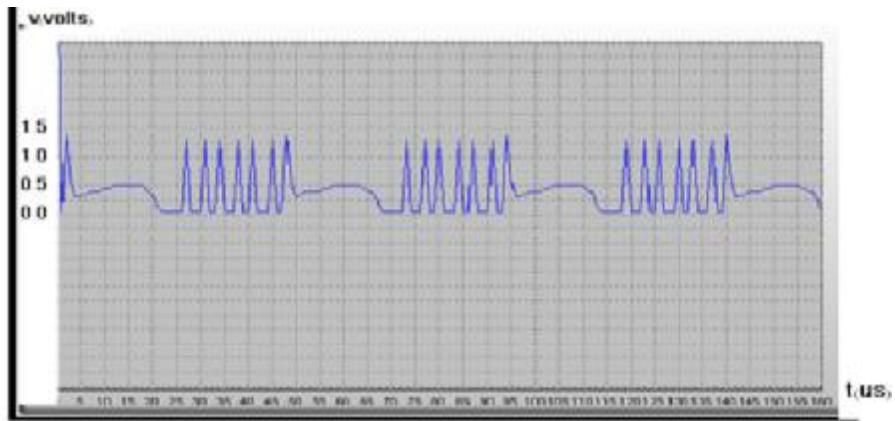

Figure (15a) O/p of pulse transformer to thyristor.



Figure(15b) Gate-Cathode waveform at load.

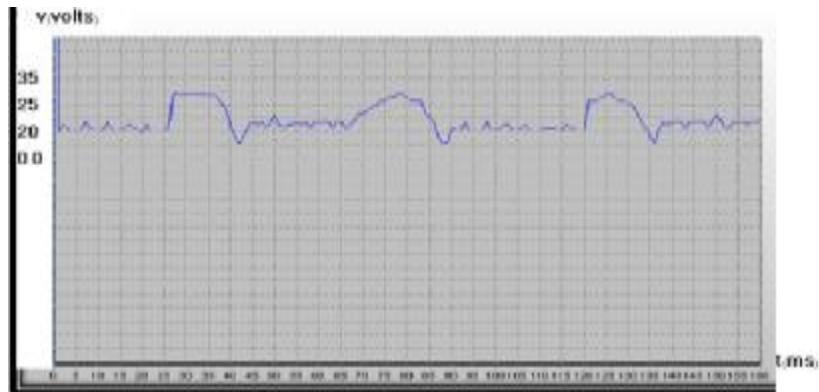

Figure (15c). O/p of Thyristor.